

MDC

Topload Washer

Refer to Page 4 for Model Numbers

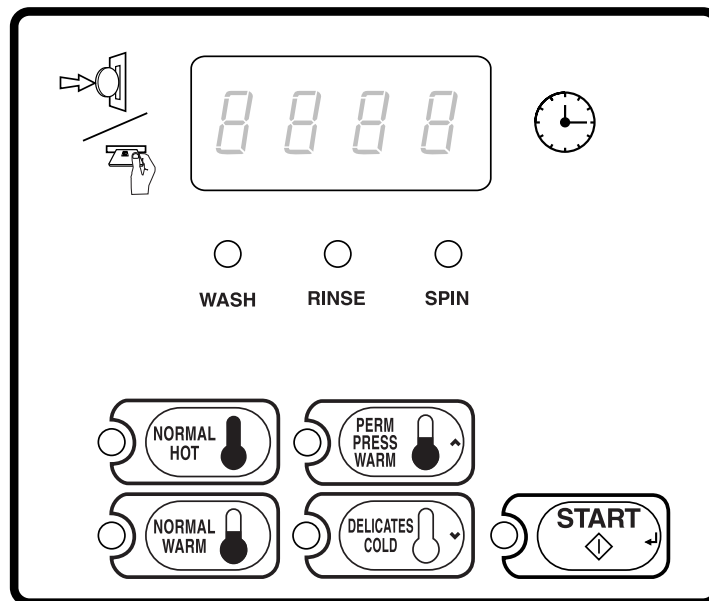

TLW1R

Keep These Instructions for Future Reference.

(If this machine changes ownership, this manual must accompany machine.)





WARNING

Failure to install, maintain, and/or operate this machine according to the manufacturer's instructions may result in conditions which can produce bodily injury and/or property damage.

W030

NOTE: The WARNING and IMPORTANT instructions appearing in this manual are not meant to cover all possible conditions and situations that may occur. It must be understood that common sense, caution, and carefulness are factors which cannot be built into these washers. These factors MUST BE supplied by the person(s) installing, maintaining, or operating the washer.

Always contact the distributor, service agent, or the manufacturer about any problems or conditions you do not understand.

Table of Contents

Model Identification	4
Preliminary Information	5
About the Control	5
Glossary of Terms.....	5
Power Failure Recovery	5
Card Reader Communications	5
MDC Identification	6
SELECT CYCLE Keypads.....	6
START Keypad	6
Display Identification	7
Light Emitting Diodes (LEDs)	7
START LED	7
WASH LED	7
RINSE LED	7
SPIN LED	7
Four 7-Segment Digits.....	7
Washer Operation	8
Start Up.....	8
Ready Mode.....	8
Opening the Washer Lid.....	8
Signals.....	8
MDC Special Features	9
Programming MDC	9
Collecting Audit Information	9
Testing Machine and MDC Functions.....	9
Rapid Advance Feature.....	9
Coin Drop	9
Start Pulse Operation	9
Service Door and Coin Vault Openings	9
Opening the Service Door (Coin Models Only)	10
Washers Prepped for Card Reader.....	10
Entering the Manual Mode	11
How to Enter the Manual Mode	11
Programming MDC	12
What Can Be Programmed?	12
Programmable Options Available.....	12
1. Vend Price “AtS”	13
2. Coin #1 Amount “dEn1”	14
3. Coin #2 Amount “dEn2”	15
4. Start Pulse Value “PLSE”	16
5. Cycle Time “CyCL”	17
6. Configuration Display “CnFg”	18
Configuration Programming	19
7. Default Cycle “dCyC”	22
Collecting Audit Information	23

© Copyright 2008, Alliance Laundry Systems LLC

All rights reserved. No part of the contents of this book may be reproduced or transmitted in any form or by any means without the expressed written consent of the publisher.

How to Enter Audit Feature.....	23
How to Read Audit Data.....	23
How to Exit Audit Feature When Using Manual Mode.....	23
Testing Machine and MDC Functions.....	24
How to Enter Testing Feature.....	24
How to Start Tests	24
How to Exit Testing Feature.....	24
Diagnostic Test Descriptions.....	24
Show Fill Time Test.....	24
Show Drain Time Test.....	24
Production Test Cycle.....	25
To Enter Production Test Cycle.....	25
To Exit Production Test Cycle.....	25
Rapid Advance Feature.....	27
How to Enter Rapid Advance from Ready Mode.....	27
How to Enter Rapid Advance During an Active Cycle.....	27
How to Use Rapid Advance	27
How to Exit Rapid Advance Feature	27
Power Fail Recovery.....	28
Default Washer Settings.....	29
Default Cycle.....	29

Model Identification

Information in this manual is applicable to these washer models:

BWTT20	SWLT21
HWLX21	SWLY20
HWTR21	SWLY21
HWTT20	SWNBC2
HWTT21	SWTT20
HWTX21	SWTT21
HWTY20	SWTX21
HWTY21	SWTY20
HWTZ20	SWTY21
HWTZ21	SWTZ20
SWLT20	SWTZ21

Preliminary Information

About the Control

MDC on the commercial washer is a programmable control that lets the owner control machine features by pressing sequences of SELECT CYCLE keypads.

MDC allows the owner to program cycle time, set vend prices, retrieve audit information and run diagnostic tests. Washers shipped from the factory have a programmable default cycle (PERM PRESS/WARM) built in.

IMPORTANT: In the event of a power failure, MDC will not have to be reprogrammed. It is designed with a memory system that will remember how it was programmed (for up to ten years) until the electrical power is restored.

IMPORTANT: It is extremely important that the washer has a positive ground and that all mechanical and electrical connections to MDC are made before applying power to or operating the washer.

Glossary of Terms

The following are a few terms and abbreviations to learn. These are referred to throughout the manual:

Four-Digit Display – This term refers to the window area of the control that displays values.

LED (Light Emitting Diode) – This term refers to the lights on the keypads and status words of the control.

Power Failure Recovery

If power fails during an active cycle, the cycle status is saved in memory. If the European Community (EC) Power Recovery is disabled, control will automatically resume the cycle (washer lid must be closed). If EC Power Recovery is enabled and power is restored in less than two seconds, the washer will automatically resume the cycle (washer lid must be closed). If the length of the power failure is greater than two seconds, the user must press the START keypad to resume the cycle.

Card Reader Communications

Card Models Only

The control will communicate with a third party card reader, available at extra cost from various card reader manufacturers. Contact the card reader manufacturer of your choice for availability and additional information.

MDC Identification

SELECT CYCLE Keypads

SELECT CYCLE keypads are used to select the specific washer cycle. These keypads include NORMAL/HOT, NORMAL/WARM, PERM PRESS/WARM, and DELICATES/COLD. The selection of one of these keypads will light up the corresponding LED. The default cycle is PERM PRESS/WARM as shipped from the factory. The SELECT CYCLE keypads are not active after the first fill cycle of the washer. Pressing the flashing START keypad will confirm selection and cycle will begin.

START Keypad

The START keypad is used to start the washer after the full vend price has been satisfied and the washer lid is closed.

Both the START keypad and the SELECT CYCLE keypads are used in various combinations for programming cycles, retrieving audit information, running diagnostic tests, and other operations described in *Entering the Manual Mode*.

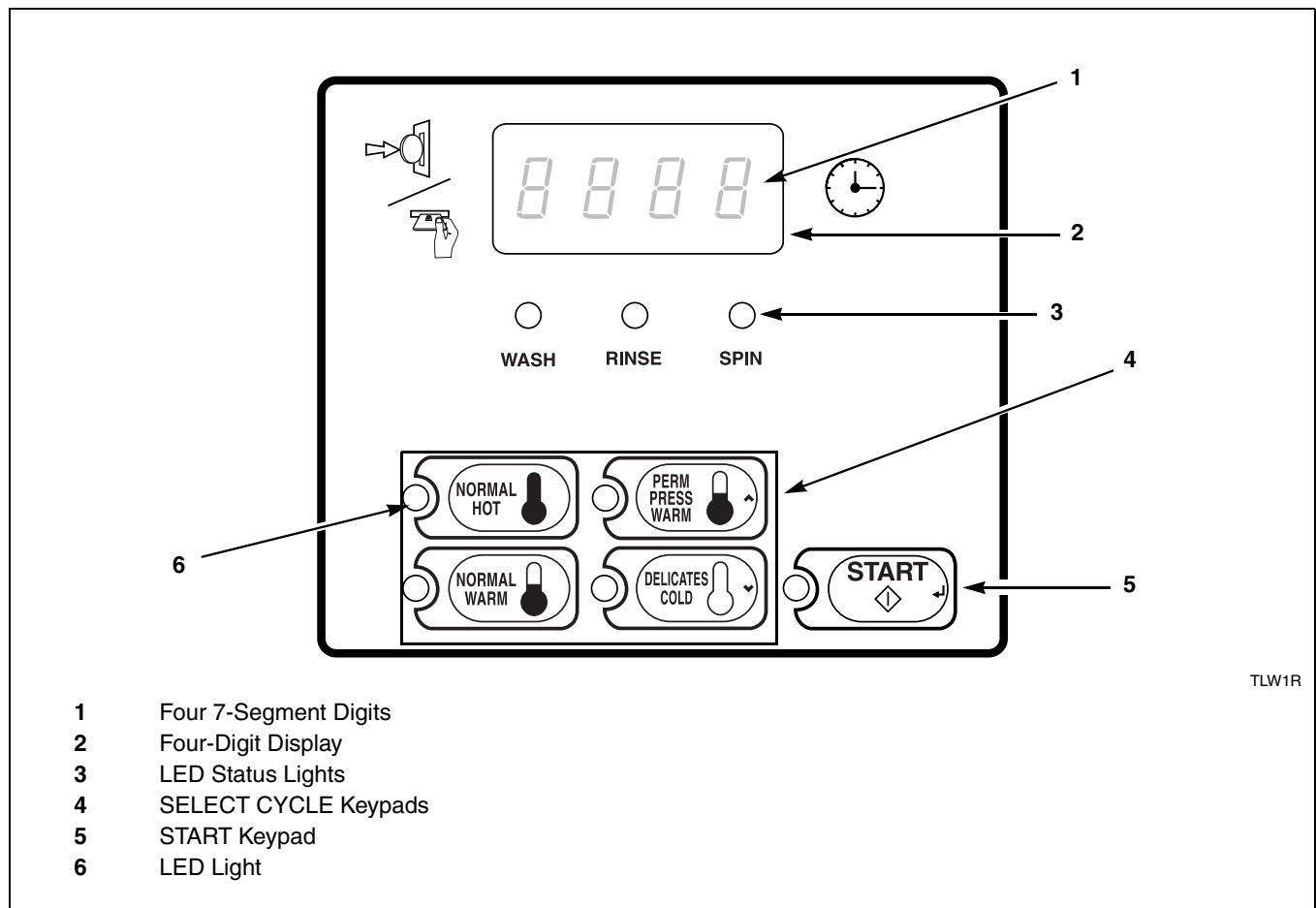

Figure 1

Display Identification

Light Emitting Diodes (LEDs)

LIGHT EMITTING DIODES (LEDs) are used to indicate the chosen cycle status. Refer to LED descriptions below.

START LED

The START keypad LED flashes whenever the washer is not in a cycle, the full vend price has been satisfied, and the washer lid is closed. When the START keypad is pressed, the cycle will begin or resume. The START LED will shut off when the START keypad is pressed.

WASH LED

The WASH LED is lit at the beginning of a wash cycle and will remain lit until the wash cycle is complete.

RINSE LED

The RINSE LED is lit at the beginning of the rinse cycle and will remain lit until the cycle is complete.

SPIN LED

The SPIN LED is lit for all spin cycles.

Four 7-Segment Digits

The 7-SEGMENT DIGITS are used to display the time remaining in a cycle, vend price, error messages and descriptive codes. When displaying the time remaining, the time value is displayed on the right side of the display. When displaying the vend price, the value is displayed on the left side of the display. During diagnostic testing or manual programming of the control, these digits will display descriptive codes and values (as described in *Entering the Manual Mode*).

Washer Operation

Start Up

When power is applied to the washer, the control will display its software version as “SXXX” (“XXX” is the version number) for two seconds. If the control was not powered down during a running cycle, it will enter the Ready Mode.

Ready Mode

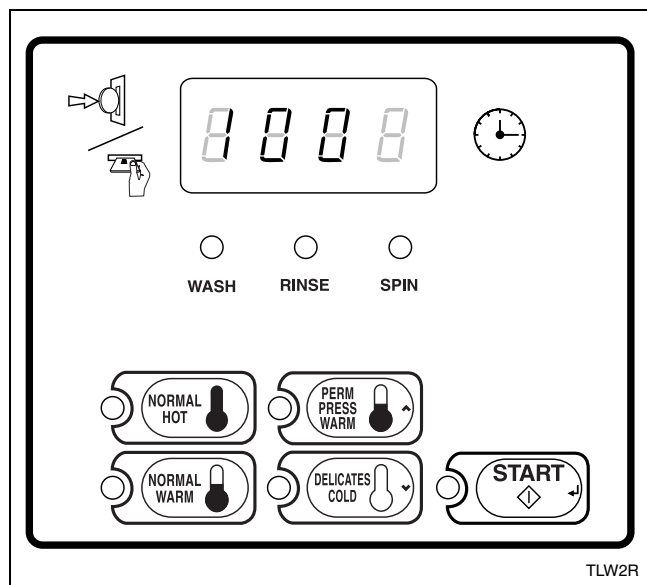

Figure 2

In Ready Mode, the PERM PRESS/WARM (default cycle) LED is lit, and the full vend price is displayed as left justified. The user may select a different cycle, if desired. (In card reader machines, if the current cycle has a vend price which differs from the default cycle, the display will be updated to show the new price.) If another cycle is selected, the control will flash the amount needed to satisfy the vend shown on the display. If the vend price is not satisfied within one minute, the washer control will stop flashing the vend price and return to the default cycle. The display will continue to show the remaining vend needed to start a cycle and will credit any vend entered by the user.

Vends may be satisfied by a coin drop, start pulses, or by a third party card reader. If a coin drop is used, the remaining vend price will decrease with each coin entry. If start pulses are used, the remaining vend price will decrease with each received pulse. Once the vend is satisfied, the START LED will begin to flash. If a third party card reader is used, the START LED will begin to flash when a valid cash card is entered into the reader.

When the START keypad is pressed, the washer will start. The START LED will stop flashing and the WASH LED will be lit. The display will change to show the remaining cycle time on the right side of the display. The appropriate LEDs will light while the machine passes through different cycle steps. Any coin entered after the first fill cycle will be added to the total coin counter, but the user will not be able to change cycles.

When a cycle is complete, the Four-Digit Display will show “00” until the lid is opened, a key is pressed, a coin or card is entered, or a start pulse is received. When one of these instances occurs, the Four-Digit Display will revert back to the Ready Mode.

Opening the Washer Lid

Opening the washer lid in a running cycle will automatically stop the cycle, the Four-Digit Display will show “Lid”, and the timer will stop. Once the lid is closed, the cycle will resume from the point it was interrupted. If the washer lid is opened in the last three minutes of the cycle, the timer will continue to count down to the end of the cycle. When the timer control reaches 0 minutes, the control will return to the Ready Mode.

Signals

There are three instances when a signal may sound during washer operation. The owner may program the signal to be turned on or off (refer to **Programming MDC, option 6**). These three instances are listed below:

1. Keypad Depression Signal

The signal will sound for .25 seconds each time a keypad is pressed.

2. Coin Input/Start Pulse Input/Card Insertion Signal

The signal will sound for .25 seconds each time a coin or start pulse is received or a card is entered.

3. Machine Error Signal

The signal will sound for 15 seconds if an error occurs.

MDC Special Features

Programming MDC

MDC allows the washer owner to program special features with the use of the keypads. Audit, diagnostic, cycle and vend information may be programmed and retrieved by pressing keypad combinations.

For details on programming cycle and vend information, refer to *Programming MDC*.

Collecting Audit Information

With MDC, the washer owner is able to access valuable audit information by manual access or by a third party card reader. Audit information recorded and available to be displayed to the owner includes total coins entered, total start pulses received, and total cycles.

For detailed information on audit features, refer to *Collecting Audit Information*.

Testing Machine and MDC Functions

Special programmable diagnostic features built into MDC allow the owner to test specific information with the washer in the Ready Mode. By opening and closing the service door and then pressing various sequences of keypads, the owner may perform the following tests:

- Show Fill Time Test
- Show Drain Time Test
- Production Test

For detailed information on running diagnostic tests, refer to *Testing Machine and MDC Functions*.

Rapid Advance Feature

This feature allows the user to quickly advance through an active cycle or advance into a cycle from the Ready Mode. This feature is useful when tests must be performed immediately on a washer in an active cycle. In this case, the user can quickly advance the cycle to the end, perform the required tests, and return the washer to the active cycle.

For detailed information on using the Rapid Advance feature, refer to *Rapid Advance Feature* section.

Coin Drop

The control will accept pulses from a single or dual coin drop to satisfy vend price. Each coin drop will have the ability to start or run a cycle.

Start Pulse Operation

The control will accept pulses from a central card reader system (available at extra cost). The machine can be programmed for the value of each start pulse received. Refer to *Programming MDC, option 4*.

Service Door and Coin Vault Openings

An open service door combined with various keypad presses allows the control to enter manual modes of operation. These modes include Manual Programming, Audit Collection, and Diagnostics.

Opening the Service Door (Coin Models Only)

Manually programming MDC requires the user to open and close the service door. Opening and closing the service door trips a switch allowing access to various programming options, diagnostics and audit capabilities. The coin drawer switch must be closed to enter the Manual Mode.

The service door is located on the top of the meter case. Refer to *Figure 3*.

	WARNING
Any disassembly requiring the use of tools must be performed by a suitably qualified service person.	
W299	

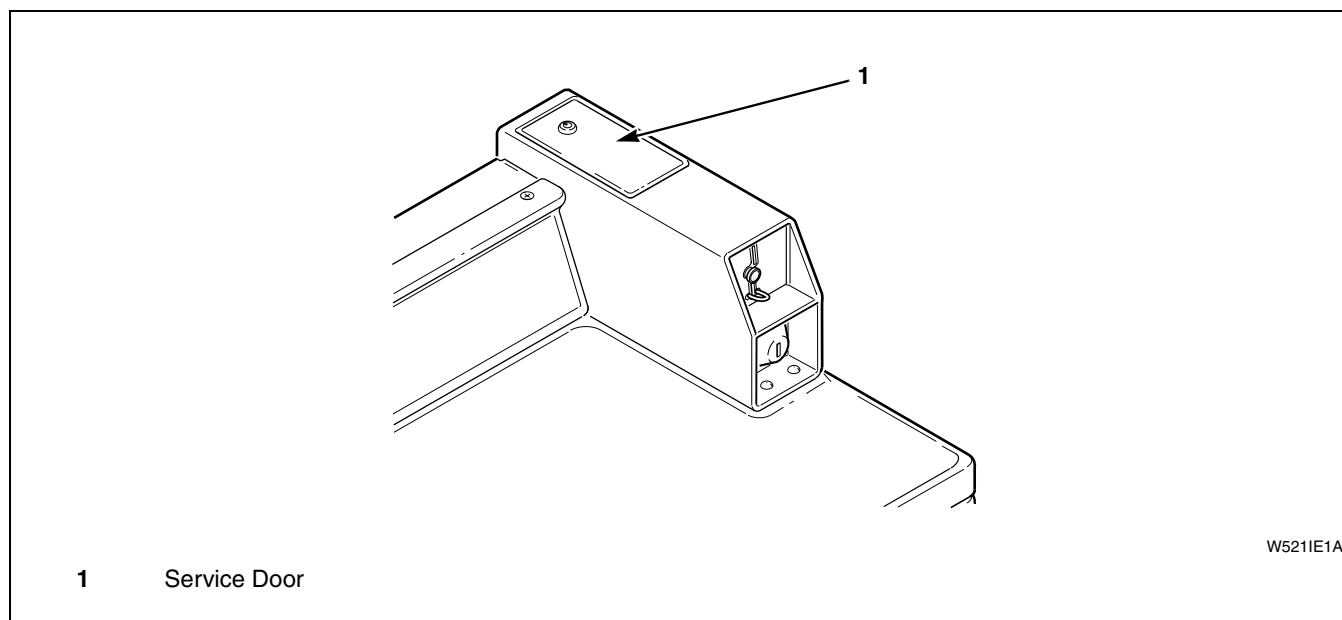

Figure 3

Washers Prepped for Card Reader

Manually programming MDC requires the user to remove the control panel and unplug the bullet connector located between the “white/black” and “red/blue” wires. This will allow the user to access various programming options, diagnostics, and audit capabilities.

Entering the Manual Mode

For programming, testing, and retrieving information from MDC, it is often necessary to enter the Manual Mode by following the six simple steps below.

How to Enter the Manual Mode

1. Be sure the washer is in the Ready Mode before continuing to step 2. If the washer is in an active cycle, rapid advance through the cycle. Refer to **Rapid Advance Feature**.
2. Open the service door. Refer to **Opening the Service Door**. The coin drawer must be closed.
3. While pressing and holding the NORMAL/HOT keypad with one hand, press the NORMAL/WARM keypad with the other hand.
4. The Four-Digit Display will show “rAPd”.

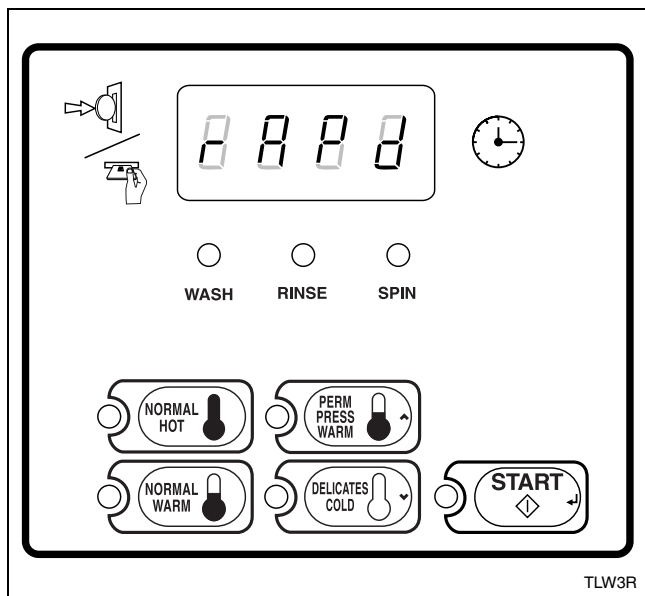

Figure 4

5. Press the PERM PRESS/WARM (^) or the DELICATES/COLD (v) keypad to scroll through the options until the desired option appears in the display.
6. Press the START (enter) keypad .

There are four manual features available. They are as follows:

1. Manual Programming (PrOg)
2. Manual Audit (Audt)
3. Diagnostic Tests (dIAG)
4. Manual Rapid Advance (rAPd)

Once in the Manual Mode, continue on into one of the features described in detail on the following pages.

Instructions on how to exit each feature are found at the end of each feature description.

Programming MDC

What Can Be Programmed?

This feature allows the owner to program cycle parameters, standard vend pricing, and other features by using the keypads.

This section offers a detailed description of all seven options available for programming.

Each description includes instructions on when and why the option might be used and, more importantly, how to program the option.

For more advanced users, a quick reference list of the options available through the Programming Mode is located on this page.

NOTE: The letters in the Option column of the Programmable Options List are what will show in the Four-Digit Display when that option is selected.

Programmable Options Available

Option	Description
AtS	Vend Price
dEn1	Coin # 1 Amount
dEn2	Coin #2 Amount
PLSE	Start Pulse Value
CyCL	Cycle Time
CnFg	Configuration Display
dCyC	Default Cycle (software version "S003" and higher only)

1. Vend Price “AtS”

This option allows the owner to set the vend price. The vend price will be displayed in the Four-Digit Display.

Program this option whenever the vend price needs to be changed.

How to Program Vend Price

1. Control must be in Manual Mode. Refer to *Entering the Manual Mode*.
2. Press the PERM PRESS/WARM (^) or the DELICATES/COLD (v) keypad until “PrOg” appears in the Four-Digit Display.

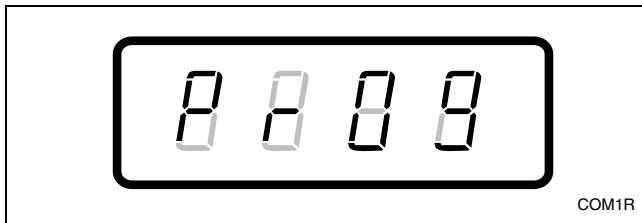

Figure 5

3. Press the START (enter) keypad.
4. Press the PERM PRESS/WARM (^) or the DELICATES/COLD (v) keypad to scroll through the programmable options until “AtS” appears in the Four-Digit Display.

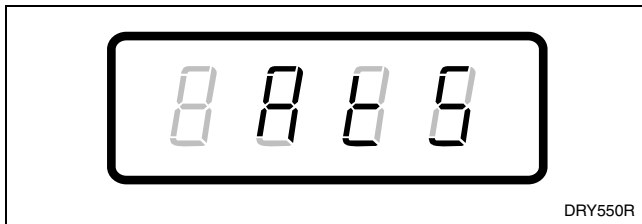

Figure 6

5. When “AtS” appears in the Four-Digit Display, press the START (enter) keypad. There are four digits in Vend Price and the fourth digit will become the active digit. The active digit will flash one second on and one second off.

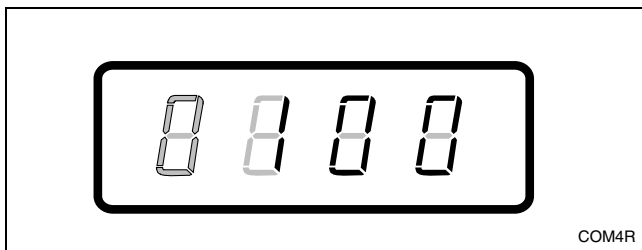

Figure 7

NOTE: The vend price can be set from 0 to 9999.

6. Press the PERM PRESS/WARM (^) or the DELICATES/COLD (v) keypad to increase or decrease the value of the active digit and the START (enter) keypad to enter the value of the digit and advance to the next digit.
7. Repeat step 6 for each of the four digits. When the START (enter) keypad is pressed and the last digit is the active digit, the changes to the vend price will be saved into the memory. The next option, “dEn1”, will appear in the Four-Digit Display.

NOTE: To program “dEn1” (Coin #1 Amount), refer to option 2. To program other options, refer to the appropriate section.

How to Exit Programming Feature

1. Be sure the control shows a programmable option, not a value.
2. While pressing and holding the NORMAL/HOT keypad with one hand, press the NORMAL/WARM keypad with the other hand. The control will revert back to the previous mode of operation.

Programming MDC

2. Coin #1 Amount “dEn1”

This option allows the owner to set a specific numerical value for a coin entered. For example, in the United States, the coin value for one quarter would be measured in cents (25). Therefore, the coin amount entered for one quarter would be 0025.

If the vend price (option 1) is set for “75”, and the coin amount is set for “0025”, the vend price displayed will decrease by 25 for each coin entered.

How to Program Coin #1 Amount

1. Control must be in Manual Mode. Refer to *Entering the Manual Mode*.
2. Press the PERM PRESS/WARM (^) or the DELICATES/COLD (v) keypad until “PrOg” appears in the Four-Digit Display.

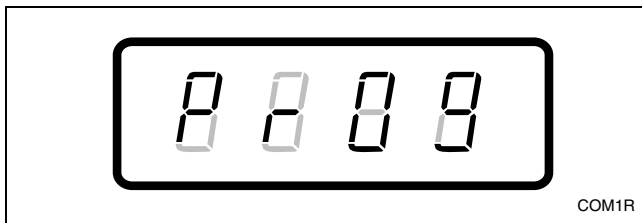

Figure 8

3. Press the START (enter) keypad and “AtS” will appear in the Four-Digit Display.
4. Press the PERM PRESS/WARM (^) or the DELICATES/COLD (v) keypad to scroll through the programmable options until “dEn1” appears in the Four-Digit Display.

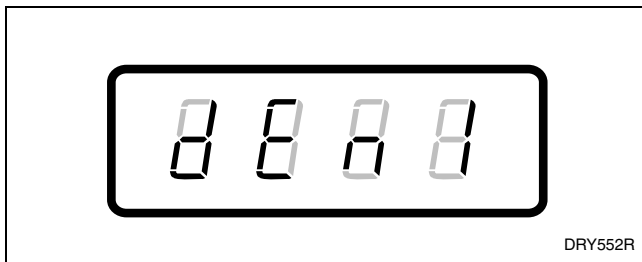

Figure 9

5. When “dEn1” appears in the Four-Digit Display, press the START (enter) keypad. There are four digits in Coin #1 Amount, and the fourth digit will become the active digit. The active digit will flash one second on and one second off.

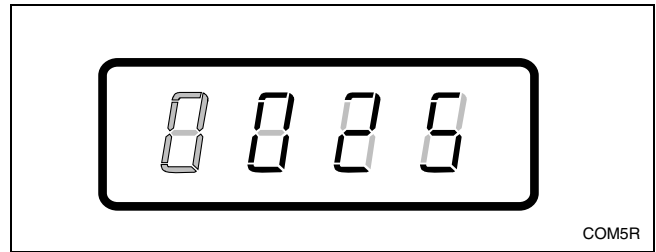

Figure 10

NOTE: The coin amount can be set from 1 to 9999.

6. Press the PERM PRESS/WARM (^) or the DELICATES/COLD (v) keypad to increase or decrease the value of the active digit and the START (enter) keypad to enter the value of the digit and advance to the next digit.
7. Repeat step 6 for each of the four digits. When the START (enter) keypad is pressed and the last digit is the active digit, the changes to the coin #1 amount will be saved into the memory. The next option, “dEn2”, will appear in the Four-Digit Display.

NOTE: To program “dEn2” (Coin #2 Amount), refer to option 3. To program other options, refer to the appropriate section.

How to Exit Programming Feature

1. Be sure the control shows a programmable option, not a value.
2. While pressing and holding the NORMAL/HOT keypad with one hand, press the NORMAL/WARM keypad with the other hand. The control will revert back to the previous mode of operation.

3. Coin #2 Amount “dEn2”

This option allows the owner to set a specific numerical value for a coin entered when using the dual coin drop. For example, the coin value for a dollar coin would be measured in cents (100). Therefore, the coin amount entered for one dollar coin would be 0100.

If the vend price (option 1) is set for “200”, and the coin amount is set for “0100”, the vend price displayed will decrease by 100 for each coin entered.

How to Program Coin #2 Amount

1. Control must be in Manual Mode. Refer to *Entering the Manual Mode*.
2. Press the PERM PRESS/WARM (^) or the DELICATES/COLD (v) keypad until “PrOg” appears in the Four-Digit Display.

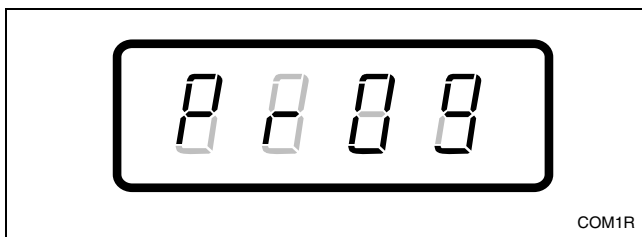

Figure 11

3. Press the START (enter) keypad and “AtS” will appear in the Four-Digit Display.
4. Press the PERM PRESS/WARM (^) or the DELICATES/COLD (v) keypad to scroll through the programmable options until “dEn2” appears in the Four-Digit Display.

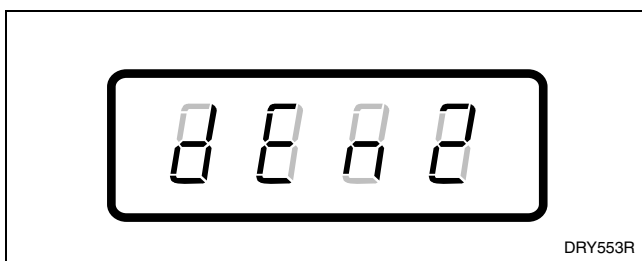

Figure 12

5. When “dEn2” appears in the Four-Digit Display, press the START (enter) keypad. There are four digits in Coin #2 Amount, and the fourth digit will become the active digit. The active digit will flash one second on and one second off.

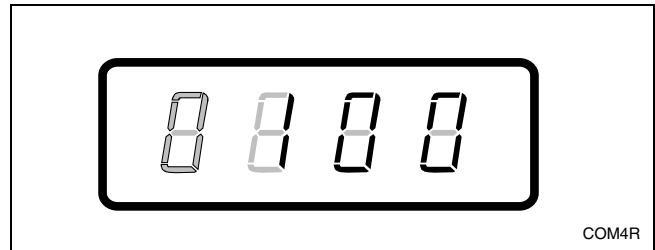

Figure 13

NOTE: The coin amount can be set from 1 to 9999.

6. Press the PERM PRESS/WARM (^) or the DELICATES/COLD (v) keypad to increase or decrease the value of the active digit and the START (enter) keypad to enter the value of the digit and advance to the next digit.
7. Repeat step 6 for each of the four digits. When the START (enter) keypad is pressed and the last digit is the active digit, the changes to the coin #2 amount will be saved into the memory. The next option, “PLSE”, will appear in the Four-Digit Display.

NOTE: To program “PLSE” (Start Pulse Value), refer to option 4. To program other options, refer to the appropriate section.

How to Exit Programming Feature

1. Be sure the control shows a programmable option, not a value.
2. While pressing and holding the NORMAL/HOT keypad with one hand, press the NORMAL/WARM keypad with the other hand. The control will revert back to the previous mode of operation.

Programming MDC

4. Start Pulse Value “PLSE”

This option allows the owner to program the value of the start pulse with an aftermarket central card reader or pay system.

How to Program Start Pulse Value

1. Control must be in Manual Mode. Refer to *Entering the Manual Mode*.
2. Press the PERM PRESS/WARM (^) or the DELICATES/COLD (v) keypad until “PrOg” appears in the Four-Digit Display.

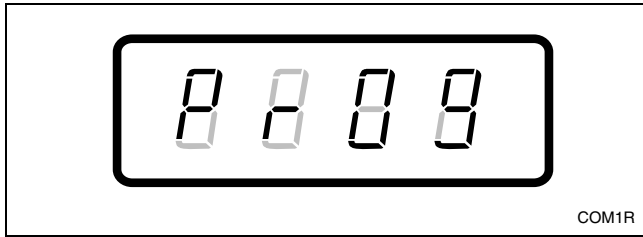

Figure 14

3. Press the START (enter) keypad and “AtS” will appear in the Four-Digit Display.
4. Press the PERM PRESS/WARM (^) or the DELICATES/COLD (v) keypad to scroll through the programmable options until “PLSE” appears in the Four-Digit Display.

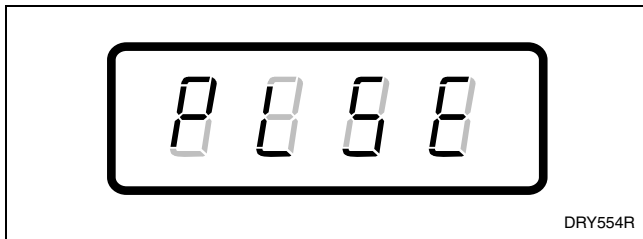

Figure 15

5. When “PLSE” appears in the Four-Digit Display, press the START (enter) keypad. There are four digits in Start Pulse Value, and the fourth digit will become the active digit. The active digit will flash one second on and one second off.

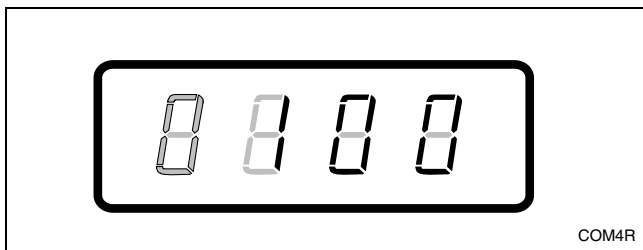

Figure 16

NOTE: The start pulse can be set from 1 to 9999.

6. Press the PERM PRESS/WARM (^) or the DELICATES/COLD (v) keypad to increase or decrease the value of the active digit and the START (enter) keypad to enter the value of the digit and advance to the next digit.
7. Repeat step 6 for each of the four digits. When the START (enter) keypad is pressed and the last digit is the active digit, the changes to the start pulse value will be saved into the memory. The next option, “CyCL”, will appear in the Four-Digit Display.

NOTE: To program “CyCL” (Cycle Time), refer to option 5. To program other options, refer to the appropriate section.

How to Exit Programming Feature

1. Be sure the control shows a programmable option, not a value.
2. While pressing and holding the NORMAL/HOT keypad with one hand, press the NORMAL/WARM keypad with the other hand. The control will revert back to the previous mode of operation.

5. Cycle Time “CyCL”

This option allows the owner to set the length of time for all cycles.

How to Program Cycle Time

1. Control must be in Manual Mode. Refer to *Entering the Manual Mode*.
2. Press the PERM PRESS/WARM (^) or the DELICATES/COLD (v) keypad until “PrOg” appears in the Four-Digit Display.

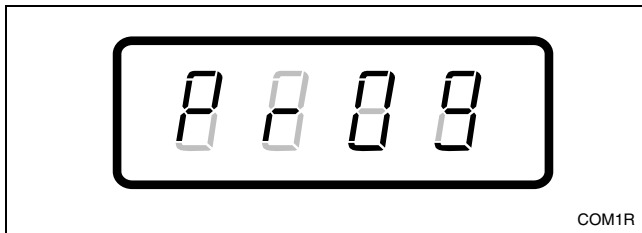

Figure 17

3. Press the START (enter) keypad and “AtS” will appear in the Four-Digit Display.
4. Press the PERM PRESS/WARM (^) or the DELICATES/COLD (v) keypad to scroll through the programmable options until “CyCL” appears in the Four-Digit Display.

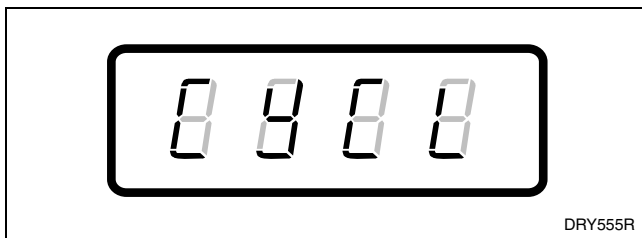

Figure 18

5. When “CyCL” appears in the Four-Digit Display, press the START (enter) keypad. A two-letter code will appear in the Four-Digit Display. This code (found below) corresponds to the cycle time.

SH = Short Cycle

LO = Long Cycle

6. Press the PERM PRESS/WARM (^) or the DELICATES/COLD (v) keypad to increase or decrease the current code displayed in the Four-Digit Display to the desired code.

7. Press the START (enter) keypad when the correct code appears in the Four-Digit Display. The next option, “CnFg”, will appear in the Four-Digit Display.

NOTE: To program “CnFg” (Configuration Display), refer to option 6. To program other options, refer to the appropriate section.

How to Exit Programming Feature

1. Be sure the control shows a programmable option, not a value.
2. While pressing and holding the NORMAL/HOT keypad with one hand, press the NORMAL/WARM keypad with the other hand. The control will revert back to the previous mode of operation.

Programming MDC

6. Configuration Display “CnFg”

This option allows the owner to turn ON or turn OFF preprogrammed capabilities within MDC.

How to Program Configuration Display

1. Control must be in Manual Mode. Refer to *Entering the Manual Mode*.
2. Press the PERM PRESS/WARM (^) or the DELICATES/COLD (v) keypad until “PrOg” appears in the Four-Digit Display.

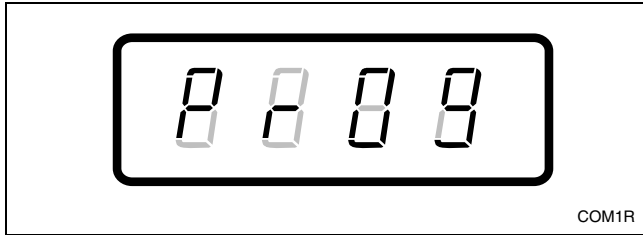

Figure 19

3. Press the START (enter) keypad and “AtS” will appear in the Four-Digit Display.
4. Press the PERM PRESS/WARM (^) or the DELICATES/COLD (v) keypad to scroll through the programmable options until “CnFg” appears in the Four-Digit Display.

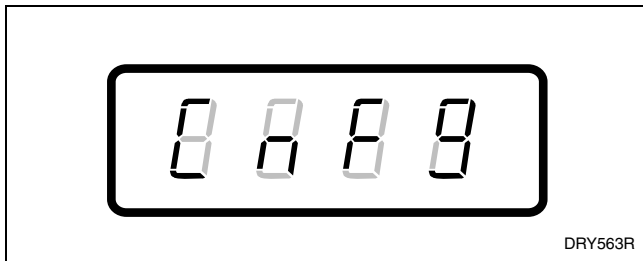

Figure 20

5. When “CnFg” appears in the Four-Digit Display, press the START (enter) keypad. A number will appear in the Four-Digit Display. This number corresponds to the current configuration value.

6. Press the PERM PRESS/WARM (^) or the DELICATES/COLD (v) keypad to increase or decrease the current number to the desired number selected from *Table 1*, *Table 2* or *Table 3*.
7. Press the START (enter) keypad when the correct number appears in the Four-Digit Display. The next option will appear in the Four-Digit Display. (On software versions less than “S003”, the first option, “AtS”, will appear in the Four-Digit Display. On software version “S003” and higher, “dCyC” will appear in the Four-Digit Display.)

NOTE: To program “dCyC” (Default Cycle), refer to option 7. To program other options, refer to the appropriate section.

How to Exit Programming Feature

1. Be sure the control shows a programmable option, not a value.
2. While pressing and holding the NORMAL/HOT keypad with one hand, press the NORMAL/WARM keypad with the other hand. The control will revert back to the previous mode of operation.

Configuration Programming

Use *Table 1*, *Table 2* or *Table 3* to turn on or turn off the preprogrammed Card Reader Display Control, Audio Signal, Error Mode, Coin Drop #1 and EC Power Recovery in MDC.

To change any or all of these configuration options, review the following descriptions carefully and choose the appropriate configuration value from *Table 1*, *Table 2* or *Table 3*. Enter the appropriate value in step 6 on the previous page.

Card Reader Display Control	This option, when enabled, prevents the control from displaying certain card operation-related messages on the Four-Digit Display to allow a third party card reader to display messages on the Four-Digit Display.
	OFF = Turns on control generated display messages.
	ON = Turns off control generated display messages.
Audio Signal	This option determines whether the audio signal will sound for machine errors, keypad depression, coins/start pulse received, or card insertion.
	OFF = Turns audio signal off.
	ON = Turns audio signal on.
Error Mode	This option determines whether the Fill and Drain Error Modes occur. If programmed off, the Fill Error will not occur and the machine will continue to wait for the fill level to be reached. In addition, the Drain Error will not occur and the machine cycle will advance to the next cycle step as though the water had been pumped out.
	OFF = Turns off Error Mode.
	ON = Turns on Error Mode.
Coin Drop #1	This option determines whether the control will accept a pulse from Coin Drop #1.
	Coin Drop #1 = Turns on Coin Drop #1.
EC Power Recovery	This option determines if the European Community Power Recovery feature is enabled. If enabled and a power failure lasts at least two seconds, the control will require the user to press the START keypad to resume the cycle that was in operation at the time of the power failure.
	OFF = Turns off the European Community Power Recovery feature.
	ON = Turns on the European Community Power Recovery feature.

Programming MDC

Use *Table 1* for software versions “S006” and lower.
To determine the software version of the control, refer to *Start Up*.

Value	Card Reader Display Control	Audio Signal	Error Mode	Coin Drop #1	EC Power Recovery
16	OFF	OFF	OFF	Coin Drop #1	OFF
17	OFF	OFF	OFF	Coin Drop #1	ON
20	OFF	OFF	ON	Coin Drop #1	OFF
21	OFF	OFF	ON	Coin Drop #1	ON
24	OFF	ON	OFF	Coin Drop #1	OFF
25	OFF	ON	OFF	Coin Drop #1	ON
28 (default)	OFF	ON	ON	Coin Drop #1	OFF
29	OFF	ON	ON	Coin Drop #1	ON
48	ON	OFF	OFF	Coin Drop #1	OFF
49	ON	OFF	OFF	Coin Drop #1	ON
52	ON	OFF	ON	Coin Drop #1	OFF
53	ON	OFF	ON	Coin Drop #1	ON
56	ON	ON	OFF	Coin Drop #1	OFF
57	ON	ON	OFF	Coin Drop #1	ON
60	ON	ON	ON	Coin Drop #1	OFF
61	ON	ON	ON	Coin Drop #1	ON

Table 1

Use *Table 2* for software version “S007”. To determine the software version of the control, refer to *Start Up*.

Value	Card Reader Display Control	Audio Signal	Error Mode	Coin Drop #1	EC Power Recovery
80	OFF	OFF	OFF	Coin Drop #1	OFF
81	OFF	OFF	OFF	Coin Drop #1	ON
84	OFF	OFF	ON	Coin Drop #1	OFF
85	OFF	OFF	ON	Coin Drop #1	ON
88	OFF	ON	OFF	Coin Drop #1	OFF
89	OFF	ON	OFF	Coin Drop #1	ON
92 (default)	OFF	ON	ON	Coin Drop #1	OFF
93	OFF	ON	ON	Coin Drop #1	ON
112	ON	OFF	OFF	Coin Drop #1	OFF
113	ON	OFF	OFF	Coin Drop #1	ON
116	ON	OFF	ON	Coin Drop #1	OFF
117	ON	OFF	ON	Coin Drop #1	ON
120	ON	ON	OFF	Coin Drop #1	OFF
121	ON	ON	OFF	Coin Drop #1	ON
124	ON	ON	ON	Coin Drop #1	OFF
125	ON	ON	ON	Coin Drop #1	ON

Table 2

Use *Table 3* for software version “S008”. To determine the software version of the control, refer to *Start Up*.

Value	Card Reader Display Control	Audio Signal	Error Mode	Coin Drop #1	EC Power Recovery
0	OFF	OFF	OFF	Coin Drop #1	OFF
1	OFF	OFF	OFF	Coin Drop #1	ON
4	OFF	OFF	ON	Coin Drop #1	OFF
5	OFF	OFF	ON	Coin Drop #1	ON
8	OFF	ON	OFF	Coin Drop #1	OFF
9	OFF	ON	OFF	Coin Drop #1	ON
12 (default)	OFF	ON	ON	Coin Drop #1	OFF
13	OFF	ON	ON	Coin Drop #1	ON
32	ON	OFF	OFF	Coin Drop #1	OFF
33	ON	OFF	OFF	Coin Drop #1	ON
36	ON	OFF	ON	Coin Drop #1	OFF
37	ON	OFF	ON	Coin Drop #1	ON
40	ON	ON	OFF	Coin Drop #1	OFF
41	ON	ON	OFF	Coin Drop #1	ON
44	ON	ON	ON	Coin Drop #1	OFF
45	ON	ON	ON	Coin Drop #1	ON

Table 3

Programming MDC

7. Default Cycle “dCyC”

This option allows the owner to set the default cycle type.

NOTE: This option is available on software version “S003” or higher only.

How to Program Default Cycle

1. Control must be in Manual Mode. Refer to *Entering the Manual Mode*.
2. Press the PERM PRESS/WARM (^) or the DELICATES/COLD (v) keypad until “PrOg” appears in the Four-Digit Display.

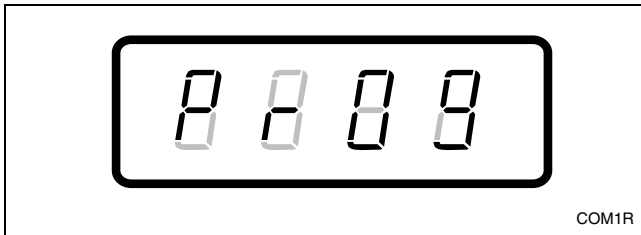

Figure 21

3. Press the START (enter) keypad and “AtS” will appear in the Four-Digit Display.
4. Press the PERM PRESS/WARM (^) or the DELICATES/COLD (v) keypad to scroll through the programmable options until “dCyC” appears in the Four-Digit Display.

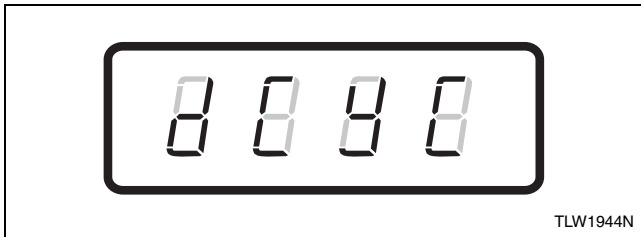

Figure 22

5. When “dCyC” appears in the Four-Digit Display, press the START (enter) keypad. A letter code will appear in the Four-Digit Display. This code (found below) corresponds to the cycle type.

hEAy = NORMAL/HOT
nOrL = NORMAL/WARM
PP = PERM PRESS/WARM
dEL = DELICATES/COLD

6. Press the PERM PRESS/WARM (^) or the DELICATES/COLD (v) keypad to increase or decrease the current code displayed in the Four-Digit Display to the desired code.

7. Press the START (enter) keypad when the correct code appears in the Four-Digit Display.

NOTE: To program other options, refer to the appropriate section.

How to Exit Programming Feature

1. Be sure the control shows a programmable option, not a value.
2. While pressing and holding the NORMAL/HOT keypad with one hand, press the NORMAL/WARM keypad with the other hand. The control will revert back to the previous mode of operation.

Collecting Audit Information

This feature allows the owner to retrieve audit information stored in the washer by pressing a sequence of pads on the control. For an explanation of the audit options available, refer to the Audit Options List on this page.

How to Enter Audit Feature

There are two methods the owner can use to enter the Audit Feature.

Entering the Audit Feature by Manual Mode

1. Control must be in Manual Mode to start. Refer to *Entering the Manual Mode*.
2. Press the PERM PRESS/WARM (^) or the DELICATES/COLD (v) keypad until "AUdt" appears in the Four-Digit Display.

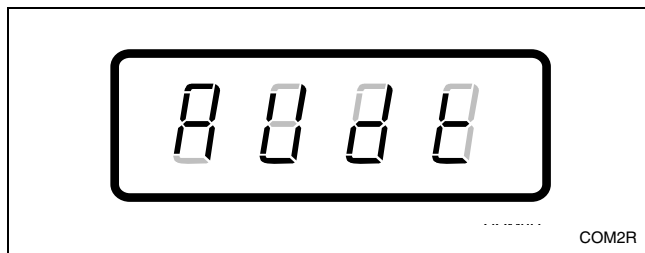

Figure 23

3. Press the START (enter) keypad. "C1" will appear in the Four-Digit Display.

NOTE: If the procedure did not work, the control will return to the Ready Mode.

Entering the Audit Feature with the Coin Vault Open

1. Open coin vault.

NOTE: The service door must be closed on machines with controls that have software versions "S003" and higher.

2. Press the START (enter) keypad.

How to Read Audit Data

1. Use the PERM PRESS/WARM (^) or the DELICATES/COLD (v) keypad to scroll through various options until the desired option is displayed in the Four-Digit Display. Refer to *Table 4* for an explanation of the audit options available.

Audit Options List	
Four-Digit Display	Description
C1	Total Number of Coins #1
C2	Total Number of Coins #2
CyC	Total Number of Machine Cycles
SP	Total Number of Start Pulses

Table 4

2. Once the desired option appears in the Four-Digit Display, press the START (enter) keypad **once** to start the audit count. At this point, the display will show the four-digit number of the audit value.
3. Press the START (enter) keypad again. The control will go to the next audit option in the Audit Options List.
4. To select other audit options, repeat steps 1-3.

How to Exit Audit Feature When Using Manual Mode

1. Be sure the control shows an audit option, not a value.
2. While pressing and holding the NORMAL/HOT keypad with one hand, press the NORMAL/WARM keypad with the other hand. The control will return to the previous mode of operation.

NOTE: To exit Audit Feature when using Coin Vault Open method, owner must close coin vault.

Testing Machine and MDC Functions

This feature allows the owner to run diagnostic tests on various washer operations without servicing the washer. The following tests are available:

- Show Fill Time Test
- Show Drain Time Test

How to Enter Testing Feature

1. Control must be in Manual Mode. Refer to *Entering the Manual Mode*.
2. Press the PERM PRESS/WARM (^) or the DELICATES/COLD (v) keypad until “dIAG” appears in the Four-Digit Display.
3. Press the START (enter) keypad. Display will change to “d001”.
4. Press the PERM PRESS/WARM (^) or the DELICATES/COLD (v) keypad to scroll through the diagnostic test options.

How to Start Tests

To start a diagnostic test, refer to *Table 5*. Press the START (enter) keypad when the desired test number is displayed. For detailed information on each test, read the appropriate description on this page.

How to Exit Testing Feature

While pressing and holding the NORMAL/HOT keypad with one hand, press the NORMAL/WARM keypad with the other hand. The display will return to the previous mode of operation.

Diagnostic (Testing) Mode – Quick Reference Table		
Test Number	Diagnostic Mode	Four-Digit Display
d001	Show Fill Time Test	FXXX
d002	Show Drain Time Test	dXXX

Table 5

Diagnostic Test Descriptions

Show Fill Time Test

This test will display the average fill time. The average will be calculated by taking the average of the last four fill times.

To start test, control must be in the Testing Mode. Refer to “*How to Start Tests*” at the beginning of this section.

To enter, press the START (enter) keypad. The Four-Digit Display will show “FXXX”. The “XXX” will be the average fill time in minutes and seconds for that machine.

To exit the Show Fill Time Test, press and hold the NORMAL/HOT keypad with one hand, then press the NORMAL/WARM keypad with the other hand. The control will return to the Testing Mode and will display “d001”.

Show Drain Time Test

This test will display the average drain time. The average will be calculated by taking the average of the last four drain times.

To start test, control must be in the Testing Mode. Refer to “*How to Start Tests*” at the beginning of this section.

To enter, press the START (enter) keypad. The Four-Digit Display will show “dXXX”. The “XXX” will be the average drain time in minutes and seconds for that machine.

To exit the Show Drain Time Test, press and hold the NORMAL/HOT keypad with one hand, then press the NORMAL/WARM keypad with the other hand. The control will return to the Testing Mode and will display “d001”.

Production Test Cycle

To Enter Production Test Cycle

1. Be certain control is in Ready Mode, washer lid is closed, and access panel or coin vault is open.
2. While pressing and holding the NORMAL/WARM keypad with one hand, press the PERM PRESS/WARM keypad with the other hand.
3. When the control enters the Production Test Cycle, it will first display “SXXX” with the “XXX” showing the software version of the control.
4. The control will advance through the sequence of test steps whenever NORMAL/WARM is pressed, with the exception of the Keypad Test and Step #4 Test. Refer to *Table 6* for all tests in the Production Test Cycle.

To Exit Production Test Cycle

The control must be powered down to end the test.

Testing Machine and MDC Functions

Production Test Cycle Quick Reference Table		
Display	Test Mode	Comments
SXXX	Software Version	XXX is the software version number.
PAdX	Keypad Test	When a key is pressed, the control will display the number assigned to the keypad (1 – NORMAL/HOT, 2 – NORMAL/WARM, 3 – PERM PRESS/WARM, 4 – DELICATES/COLD, 5 – START). As each keypad is pressed, its corresponding LED will be lit and remain on for the duration of the test. When all keypads have been pressed, the control will advance to Coin Drop Test step.
CXCX	Coin Drop Test	X is the number of coins entered. If dual coin drops are installed, coin drop #1 will be shown on the left of the display and coin drop #2 will be shown on the right of the display. If a single coin drop is used, only one coin count will be displayed and the other side will remain at zero.
S XX	Service Door Switch Test	XX is the number of service door switch openings.
U XX	Coin Vault Test	XX is the number of coin vault openings.
All LEDs and display segments will light	Show Entire Display Mode	None
0001	Step #1 Test	SPIN LED is lit and control energizes the high speed spin motor outputs.
0002	Step #2 Test	Motor outputs are off and hot water valve is on.
0003	Step #3 Test	Motor outputs are off and cold water valve is on.
0004	Step #4 Test	Motor outputs are off and hot and cold water valves are on. Control will remain in this mode until machine fills and pressure switch opens. All keypad presses are ignored until step is complete.
0005	Step #5 Test	RINSE LED is lit and control energizes the high speed agitate motor outputs.
0006	Step #6 Test	RINSE LED is lit and control energizes low speed spin motor outputs.
0007	Step #7 Test	SPIN LED is lit and control energizes low speed spin motor outputs.
0008	Step #8 Test	SPIN LED is lit and control energizes high speed spin motor outputs.
0009	Step #9 Test	LEDs are off, motor outputs are off, and hot and cold water valves are on.
0010	Step #10 Test	SPIN LED is lit and control energizes high speed spin motor outputs.

Table 6

Rapid Advance Feature

The Rapid Advance feature allows the owner to quickly advance through active cycles or advance into a cycle from the Ready Mode.

How to Enter Rapid Advance from Ready Mode

1. If control is in Ready Mode, control must be put into Manual Mode. Refer to *Entering the Manual Mode*.
2. Press the PERM PRESS/WARM (^) or the DELICATES/COLD (v) keypad until “rAPd” appears in the display.
3. Press the START (enter) keypad. The Four-Digit Display will display “FFIL” for three seconds and will then show the cycle time remaining. The START LED will flash.
4. Press the START (enter) keypad to start cycle. The time remaining will show in the Four-Digit Display.

How to Enter Rapid Advance During an Active Cycle

1. Be certain service door is open and coin vault is closed.
2. While pressing and holding the NORMAL/HOT keypad with one hand, press the NORMAL/WARM keypad with the other hand. The Four-Digit Display will show “rAPd”.

How to Use Rapid Advance

While in the Rapid Advance feature, pressing the START (enter) keypad will advance the washer to the next cycle step. The cycle indicator lights and Four-Digit Display will show which cycle step the washer is in. Refer to *Table 7* for cycle steps.

Four-Digit Display	Cycle Step
FFIL	Wash Fill Cycle Step
rFIL	Rinse Fill Cycle Step
FSPn	Final Spin Cycle Step

Table 7

Continue pressing the START (enter) keypad until the cycle is completed.

How to Exit Rapid Advance Feature

Advance through the cycles until reaching the Ready Mode.

Power Fail Recovery

The Power Fail Recovery feature allows the cycle status to be saved in memory in the event of a power failure.

If a cycle is in progress when the power fails, the cycle status is saved in memory. When power recovers, the control will determine whether to automatically continue the cycle from the point it left off, requiring the user to press the START keypad to continue the cycle, or end the cycle and put the control into the Ready Mode.

If the European Community (EC) Power Fail feature is disabled, the control will automatically resume the cycle from the point it left off. Whenever the EC Power Fail feature is enabled and the power failure lasted more than two (2) seconds, the control will prompt the user to press the START keypad to continue the cycle from the point it left off.

Default Washer Settings

Default Settings	Default
Cycle Length	Long
Coin #1 Value	25
Coin #2 Value	100
Start Pulse Value	100
Vend Price	100
Control Configurations	*
Card Reader Display Control	OFF
Audio Signal	ON
Error Mode	ON
Coin Drop	ON
EC Power Fail	OFF
Default Cycle **	PERM PRESS/ WARM

* The default control configuration for software versions "S006" and lower is 28.

The default control configuration for software version "S007" is 92.

The default control configuration for software version "S008" is 12.

** This option available in software version "S003" or higher.

Default Cycle

The PERM PRESS/WARM cycle is the default cycle and is programmed in at the factory. This cycle can be made longer or shorter by reprogramming the cycle length. Refer to *Programming MDC, option 5*, to change these times. All other times are not programmable.

Cycle	Default
Wash Fill	2 minutes
Wash Agitate	9 minutes
Wash Pause	10 seconds
Wash Spin #1	24 seconds
Wash Spin #1 Pause	10 seconds
Wash Spin/Spray	0
Wash Spin #2	0
Rinse Fill	2 minutes
Rinse Agitate	5 minutes
Rinse Pause	10 seconds
Rinse Spin #1	30 seconds
Rinse Spin/Spray	30 seconds
Final Spin	7 minutes