

Commercial Frontload Washers

Refer to Page 6 for Model Numbers

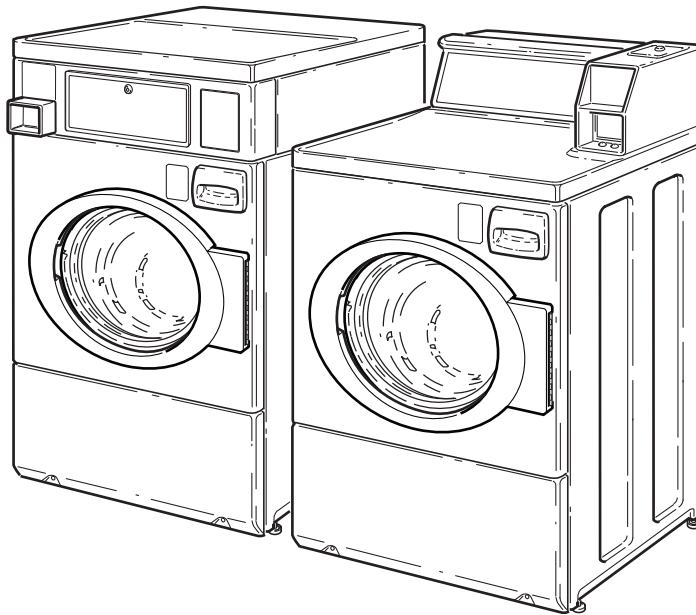

FLW1535C

Table of Contents

Section 1 – Safety Information	3
Locating an Authorized Servicer	4
Section 2 – Introduction	5
Customer Service.....	5
Nameplate Location.....	5
Model Identification	6
Theory of Operation (Coin Slide Operated Models).....	8
Theory of Operation (Electronic Control Models).....	10
Section 3 – General Troubleshooting	12
1. Motor Circuit.....	12
2. Troubleshooting Knocking Noise	13
3. Troubleshooting Coin Drop	13
4. No Spin Due to Out-of-Balance Switch Wiring Problem Starting Serial Nos. Beginning 0307	18
5. Troubleshooting LEDs on Inverter Controls Starting Machine Serial No. 0911014603	19
6. Vibration	19
7. No Spin	20
Section 4 – Coin Slide Operated Troubleshooting.....	21
8. Coin Slide Can't Be Fully Inserted	21
9. Coin Slide Switch Not Activated	22
10. Coin Slide Switch Activated Too Soon	23
11. Coin Slide Doesn't Freely Return	24
12. Error Code Listing	25
13. Washer Will Not Start – No LEDs/Lights Lit (No Response to Start Switch)	26
14. Washer Will Not Start – No Door Lock (Door Locked/Close Door LEDs Flashing)	28
15. Washer Will Not Start – In Use/Close Door LEDs Flashing (Door Must Be Closed and Attempting to Lock).....	30
16. Motor Will Not Run (Door Locked/Final Spin and Tumble LEDs Flashing).....	32
17. Washer Will Not Fill (In Use/Door Locked LEDs Flashing)	34
18. Washer Overflows.....	36
19. Pump or Drain Valve Does Not Operate	38
20. Serial Communication Error (Final Spin and Tumble/Close Door LEDs Flashing).....	40
Section 5 – NetMaster and MDC Troubleshooting	42
21. Error Code Listing	42
22. Microwand Does Not Communicate With Control – NetMaster Models Only.....	44
23. Coins Ignored When Entered.....	45

© Copyright 2010, Alliance Laundry Systems LLC

All rights reserved. No part of the contents of this book may be reproduced or transmitted in any form or by any means without the expressed written consent of the publisher.

24. No Visible Display on Control.....	46
25. Washer Will Not Start – “door” Displayed.....	48
26. Washer Will Not Start – E:dL on Display	50
27. Washer Will Not Fill (Machine Empty, No E:SP on Display) ...	52
28. Washer Overflows.....	54
29. Pump or Drain Valve Does Not Operate	56
30. Serial Communication Error (E:SP on Display)	58
31. Motor Does Not Run (E:df on Display).....	60
32. Washer Will Not Heat (“OP” or “SH” Displayed)	62
33. Washer Will Not Heat (Models Equipped with Heater) (3 Phase Heater Machines Only)	64
Section 6 – Adjustments	66
34. Cabinet Leveling Legs	66
35. Loading Door	67
36. Motor Belt Tension	68
37. Door Catch	69
38. Shipping Braces	71
39. Cleaning Non-Electronic Coin Drop.....	72
40. Cleaning Electronic Coin Drop.....	74

Section 1

Safety Information

Throughout this manual and on machine decals, you will find precautionary statements (“CAUTION,” “WARNING” and “DANGER”) followed by specific instructions. These precautions are intended for the personal safety of the operator, user, servicer, and those maintaining the machine.

▲ DANGER

Danger indicates an imminently hazardous situation that, if not avoided, will cause severe personal injury or death.

WARNING

Warning indicates a hazardous situation that, if not avoided, could cause severe personal injury or death.

CAUTION

Caution indicates a hazardous situation that, if not avoided, may cause minor or moderate personal injury or property damage.

Additional precautionary statements (“IMPORTANT” and “NOTE”) are followed by specific instructions.

IMPORTANT

The word “IMPORTANT” is used to inform the reader of specific procedures where minor machine damage will occur if the procedure is not followed.

NOTE

The word “NOTE” is used to communicate installation, operation, maintenance or servicing information that is important but not hazard related.

In the interest of safety, some general precautions relating to the operation of this machine follow.

	WARNING
<ul style="list-style-type: none">• Failure to install, maintain and/or operate this product according to the manufacturer’s instructions may result in conditions which can produce serious injury, death and/or property damage.• Do not repair or replace any part of the product or attempt any servicing unless specifically recommended or published in this Service Manual and unless you understand and have the skills to carry out the servicing.• Whenever ground wires are removed during servicing, these ground wires must be reconnected to ensure that the product is properly grounded and to reduce the risk of fire, electric shock, serious injury or death.	
<small>W006R2</small>	



WARNING

To reduce the risk of electric shock, fire, explosion, serious injury or death:

- Disconnect electric power to the washer before servicing.
- Never start the washer with any guards/panels removed.
- Whenever ground wires are removed during servicing, these ground wires must be reconnected to ensure that the washer is properly grounded.
- Motor not grounded! Disconnect electric power before servicing motor.

W485



WARNING

Repairs that are made to your products by unqualified persons can result in hazards due to improper assembly or adjustments subjecting you or the inexperienced person making such repairs to the risk of serious injury, electrical shock or death.

W007



WARNING

If you or an unqualified person perform service on your product, you must assume the responsibility for any personal injury or property damage which may result. The manufacturer will not be responsible for any injury or property damage arising from improper service and/or service procedures.

W008

NOTE: The WARNINGS and IMPORTANT INSTRUCTIONS appearing in this manual are not meant to cover all possible conditions and situations that may occur. Common sense, caution and care must be exercised when installing, maintaining or operating the washer.

Always contact your dealer, distributor, service agent or the manufacturer about any problems or conditions you do not understand.

Locating an Authorized Servicicer

Alliance Laundry Systems is not responsible for personal injury or property damage resulting from improper service. Review all service information before beginning repairs.

Warranty service must be performed by an authorized technician, using authorized factory parts. If service is required after the warranty expires, Alliance Laundry Systems also recommends contacting an authorized technician and using authorized factory parts.

Section 2

Introduction

Customer Service

If literature or replacement parts are required, contact the source from whom the machine was purchased or contact Alliance Laundry Systems at (920) 748-3950 for the name and address of the nearest authorized parts distributor.

For technical assistance, call either of the numbers listed below:

(920) 748-3121 Ripon, Wisconsin

+32 56 41 20 54 Wevelgem, Belgium

Nameplate Location

When calling or writing about your product, be sure to mention model and serial numbers. Model and serial numbers are located on nameplate(s) as shown.

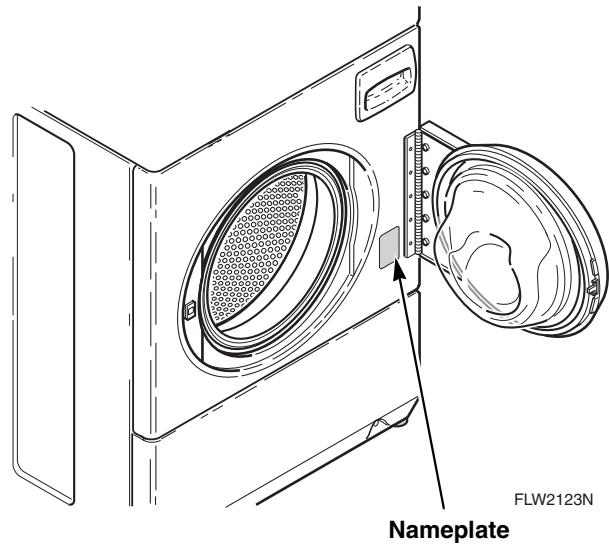

Introduction

Model Identification

Information in this manual is applicable to these washers.

Model Number	MDC	NetMaster	Coin Slide Operated
BFNBEFSP111CN01	X		
BFNBEFSP111CW01	X		
BFNBEFSP111TN01	X		
BFNBEFSP111TW01	X		
BFNBLFSP301AW01	X		
BWFL74*N4000	X		
BWFL75*N4000	X		
BWFX71*N1127	X		
BWFX71*N3050	X		
BWFX74*N4000	X		
BWFX75*N4000	X		
HFNBCFSG111TN01	X		
HFNBCFSP111TN01	X		
HFNCXFSP111CW01	X		
HFNCXRSP111CW01	X		
HWFB71*N		X	
HWFB71*N1102		X	
HWFR71*N1102	X		
HWFT71*N	X		
HWFT71*N1102	X		
HWFT73*N	X		
HWFT73*N1102	X		
HWFX71*N1102	X		
HWFX71*N1127	X		
HWFY71*N1102	X		
HWFY73*N1102	X		
HWFY74*N4000	X		
HWFY75*N4000	X		
HWR971*N1102			X
HWR971*N1127			X
HWR973*N1102			X
HWRR71*N1102	X		
HWRT71*N	X		
HWRT71*N1102	X		
HWRX71*N1102	X		
HWRX71*N1102	X		
HWRY71*N1102	X		
NWFL84*N4000	X		

* Add Letter To Designate Color. N – Stainless Steel Q – Bisque W – White

Model Number	MDC	NetMaster	Coin Slide Operated
NWFL85*N4000	X		
NWFX74*N4000	X		
NWFX75*N4000	X		
SFNBCRSP111TW02	X		
SFNCCFSP111TW01	X		
SFNCCRSP111TW01	X		
SFNCCRSP111TW02	X		
SFNCXRSP111TW02	X		
SFNCYFSP111TW01	X		
SFNCYRSP111TW01	X		
SFNSXRSP111TW02			X
SFNTXRSP111TW01			X
SFNTXRSP111TW02			X
SWFA71*N		X	
SWFA71*N3050		X	
SWFA71*N3069		X	
SWFA73*N		X	
SWFB71*N		X	
SWFB72*N		X	
SWFB73*N		X	
SWFF71*N		X	
SWFF71*N3050		X	
SWFF73*N		X	
SWFL74*N4000	X		
SWFT71*N	X		
SWFT73*N	X		
SWFX71*N	X		
SWFX71*N1127	X		
SWFX71*N3000	X		
SWFX71*N3050	X		
SWFX71*N5400	X		
SWFX73*N	X		
SWFX74*N4000	X		
SWFX75*N4000	X		
SWFY71*N	X		
SWFY73*N	X		
SWR971*N			X
SWR973*N			X
SWRB71*N		X	
SWRF71*N		X	

* Add Letter To Designate Color. N – Stainless Steel Q – Bisque W – White

Introduction

Model Number	MDC	NetMaster	Coin Slide Operated
SWRT71*N	X		
SWRT73*N	X		
SWRX71*N	X		
SWRY71*N	X		

* Add Letter To Designate Color. N – Stainless Steel Q – Bisque W – White

**Theory of Operation
(Coin Slide Operated Models)**

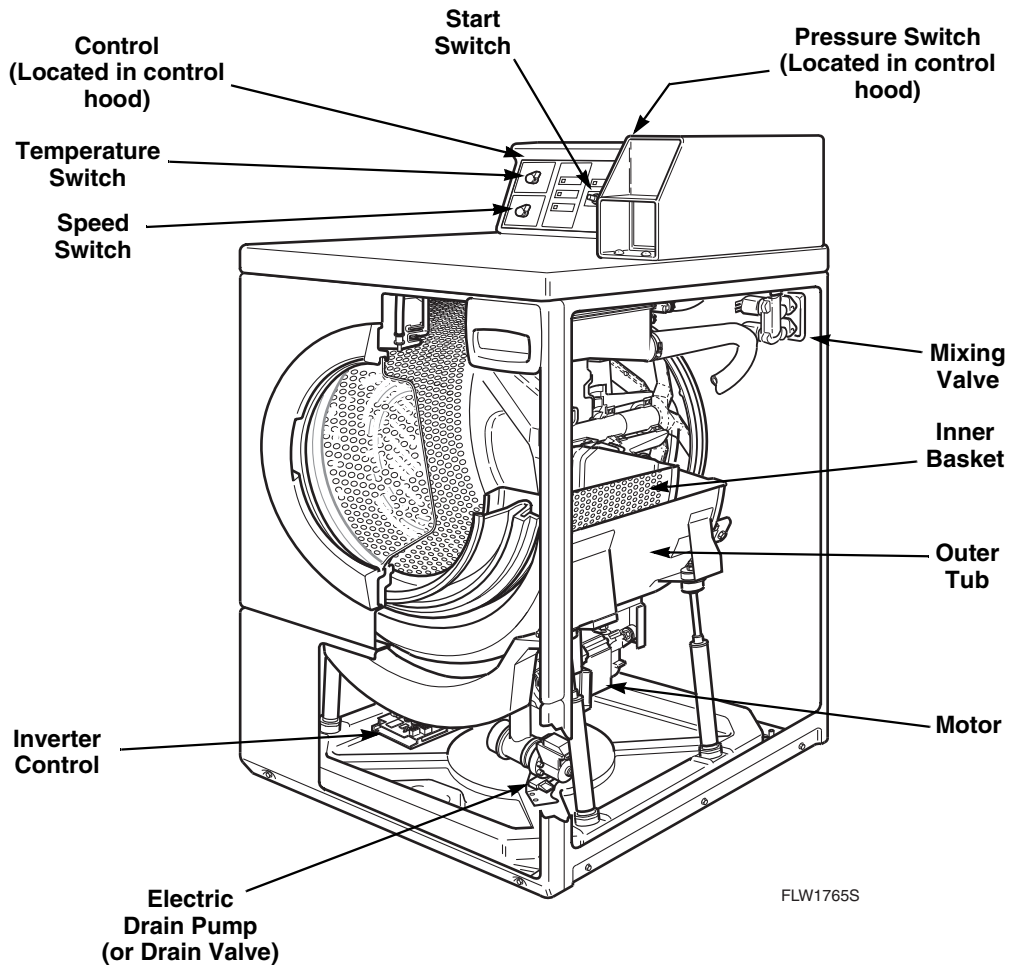

General

This frontload washer provides some of the same principles of operation as the typical topload washers. It senses water level, it dispenses the desired laundry detergent, agitates the clothes for good cleaning action, pumps the water out of the washer and spins the clothing in preparation for the dryer.

The difference in operation is primarily the rotational washing agitation created for the horizontal basket and drum. This agitation tumbles the clothes in a clockwise, pause, and counter-clockwise direction. This reversing tumbling action provides an efficient washing process and requires less laundry detergent and less water.

The cycle begins by pressing the start button, which locks the loading door after the vend is satisfied. The type of cycle and water temperature are determined by the temperature selector switch and the cycle select switch.

The inner basket starts agitating during the wash water fill. A column of air is trapped in a pressure bulb and hose. The air pressure continues to increase as the inner basket fills with water until it is great enough to activate the pressure switch which then causes the wash fill to stop.

The regular and perm press agitate cycle tumble the clothing in a clockwise direction for a period of 15 seconds, pauses for nine seconds and then tumbles the clothing in a counterclockwise direction for 15 seconds. This agitation continues until the end of the wash cycle. The machine stops agitating and turns on the pump or drain valve which removes the wash water.

Upon completion of the wash cycle, the machine goes into two rinse cycles. Fresh cold water is brought into the inner basket via the mixing valve until the pressure switch shuts off the water while agitating. The rinse cycle consists of agitation for a predetermined amount of time, then a spin mode with the pump running while the machine goes into a series of 4 short 500 RPM spins.

After all the rinse cycles have been completed, the washer goes into a final high spin cycle to extract as much water as possible from the clothing to prepare them for the dryer. The spin speeds and duration of this final high spin cycle are determined by the type of wash cycle selected. Refer to *Table 1* or *Table 2*.

NOTE: Washer may not reach 1000 RPM because of an out-of balance condition. Control may limit speed to 850, 650 or 500 RPM depending on severity of out-of-balance condition.

Models Through Serial No. 0911014602

	Regular	Perm Press	Delicate
650 RPM	3 minutes	4 minutes	4 minutes
1000 RPM	3 minutes	2 minutes	0 minutes

Table 1

Models Starting Serial No. 0911014603

	Regular	Perm Press	Delicate
500 RPM	0 minutes	0 minutes	4 minutes
650 RPM	3 minutes	6 minutes	0 minutes
1000 RPM	3 minutes	0 minutes	0 minutes

Table 2

Technical

The basic operational system of this washer consists of the control, temperature switch, inverter control, pressure switch, water valves, electric pump (or drain valve), A.C. motor, transformer and cycle select switch.

The control performs all timing functions like the timer in a topload washer.

The inverter control uses a speed sensor on the motor to measure the drum RPM. Before entering any spin step, the inverter control measures the RPM of motor to sense out-of-balance. The inverter control will try to redistribute the clothes if an out-of-balance condition exists; the inverter control will limit the spin speed to several speeds depending on the severity of the out-of-balance condition. If the out-of-balance condition is severe enough, the inverter control will limit speed to 90 RPM and will not spin.

NOTE: An additional out-of-balance switch is used to detect any out-of-balance condition during spins. If this switch opens during a spin step, the inverter control immediately stops and then restarts the spin.

Theory of Operation (Electronic Control Models)

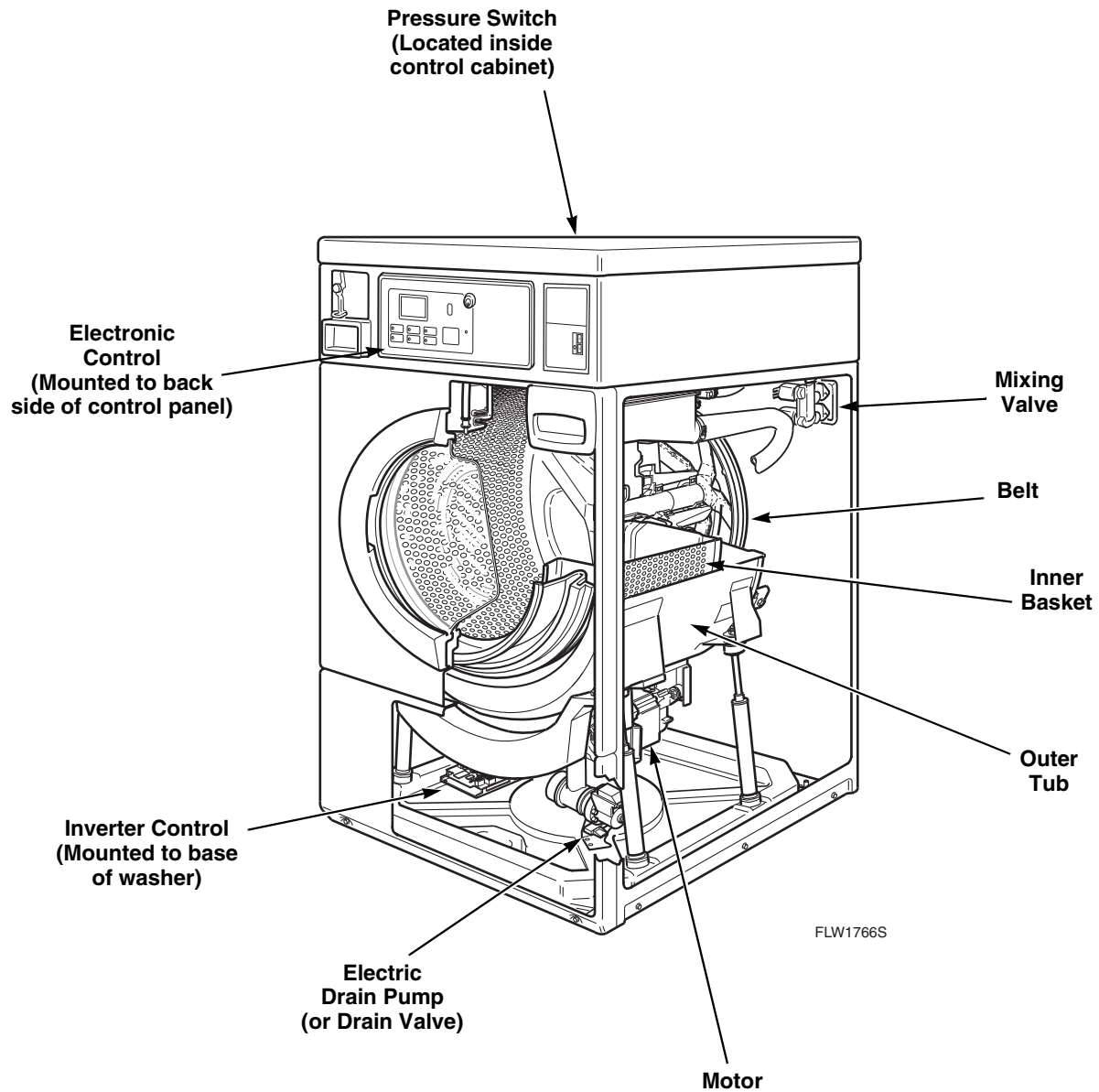

General

This frontload washer provides some of the same principles of operation as the typical topload washers. It senses water level, it dispenses the desired laundry detergent, agitates the clothes for good cleaning action, removes the water out of the washer and spins the clothing in preparation for the dryer.

The difference in operation is primarily the rotational washing agitation created for the horizontal basket and drum. This agitation tumbles the clothes in a clockwise,

pause, and counter-clockwise direction. This reversing tumbling action provides an efficient washing process and requires less laundry detergent and less water.

The cycle begins by locking the loading door after the vend is satisfied. The type of cycle and water temperature are determined by the appropriate pads on the electronic control.

The inner basket starts agitating during the wash water fill. A column of air is trapped in a pressure bulb and hose. The air pressure continues to increase as the inner

basket fills with water until it is great enough to activate the pressure switch which then causes the wash fill to stop.

The agitate cycle tumbles the clothing in a clockwise direction for a period of 15 seconds, pauses for nine seconds and then tumbles the clothing in a counterclockwise direction for 15 seconds. This agitation continues until the end of the wash cycle. The machine stops agitating and turns on the pump or drain valve which removes the wash water.

Upon completion of the wash cycle, the machine goes into a rinse cycle. Fresh cold water is brought into the inner basket via the mixing valve until the pressure switch shuts off the water while agitating. The rinse cycle consists of agitation for a predetermined amount of time then a spin mode with the pump running where the machine goes into a series of 4 short 500 RPM spins. Two of these rinse cycles will normally take place with a third extra rinse cycle being optional.

After all the rinse cycles have been completed, the washer goes into a final high spin cycle to extract as much water as possible from the clothing to prepare them for the dryer. The spin speeds and duration of this final high spin cycle are determined by the type of wash cycle selected. Refer to *Table 3* or *Table 4*.

NOTE: Washer may not reach 1000 RPM because of an out-of-balance condition. Control may limit speed to 850, 650 or 500 RPM depending on severity of out-of-balance condition.

Models Through Serial No. 0911014602

	Regular	Perm Press	Delicate
650 RPM	3 minutes	4 minutes	4 minutes
1000 RPM	3 minutes	2 minutes	0 minutes

Table 3

Models Starting Serial No. 0911014603

	Regular	Perm Press	Delicate
500 RPM	0 minutes	0 minutes	4 minutes
650 RPM	3 minutes	6 minutes	0 minutes
1000 RPM	3 minutes	0 minutes	0 minutes

Table 4

Technical

The basic operational system of this washer consists of the electronic control, the inverter control, pressure switch, water valves, electric pump (or drain valve) and A.C. motor.

The electronic control performs all control and timing functions like the timer in a topload washer. The electronic control sends simple speed and output commands to the inverter control via serial communication. The electronic control powers the door lock, pump (or drain valve) and the inverter control.

The inverter control powers the A.C. motor and performs all motor control functions. The inverter control also powers the water and dispenser valves and passes the pressure switch status to the electronic control. The inverter control is powered through the door switch, door lock switch and electronic control. The inverter control also alerts the electronic control to any errors in the motor.

The inverter control uses a speed sensor on the motor to measure the drum RPM. Before entering any spin step the inverter control measures the RPM of the drum to sense out-of-balance. The inverter control will try to redistribute the clothes if an out-of-balance condition exists the inverter control will limit the spin speed to several speeds depending on the severity of the out-of-balance condition. If the out-of-balance condition is severe enough the inverter control will limit speed to 90 RPM and will not spin.

NOTE: An additional out-of-balance switch is used to detect any out-of-balance condition during spins. If this switch opens during a spin step, the inverter control immediately stops and then restarts the spin.

Section 3

General Troubleshooting



WARNING

To reduce the risk of electric shock, fire, explosion, serious injury or death:

- Disconnect electric power to the washer before servicing.
- Never start the washer with any guards/panels removed.
- Whenever ground wires are removed during servicing, these ground wires must be reconnected to ensure that the washer is properly grounded.
- Motor not grounded! Disconnect electric power before servicing motor.

W485

1. Motor Circuit

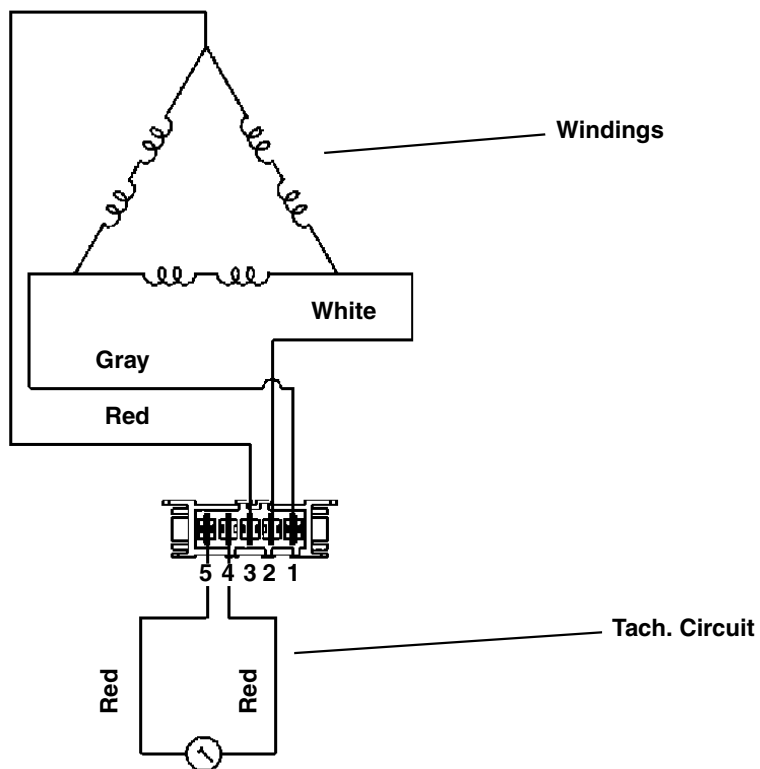

Resistance Values:

Tachometer Circuit:
Terminals 4-5
Approx. **115** ohms

Windings:

Terminals 1-2, 2-3, 1-3
Approx. **4.5** ohms



WARNING

To reduce the risk of electric shock, fire, explosion, serious injury or death:

- Disconnect electric power to the washer before servicing.
- Never start the washer with any guards/panels removed.
- Whenever ground wires are removed during servicing, these ground wires must be reconnected to ensure that the washer is properly grounded.
- Motor not grounded! Disconnect electric power before servicing motor.

W485

2. Troubleshooting Knocking Noise

If a frontload washer produces a noise similar to a knock on a door, it might be due to a flat spot on the belt. The knocking sound is made when the flat spot hits the pulley. The knocking may occur during a pulse spin and fade after reaching a higher RPM.

To correct this condition, replace the belt.

3. Troubleshooting Coin Drop

a. Non-Electronic Coin Drops:

When coin is placed into coin slot, the coin should roll down drop and be heard dropping into coin vault. If coin does not fall into coin vault or if coin drop sensor does not register that coin has been entered, follow troubleshooting instructions on following page. Refer to *Figure 1* for path that coin follows when working properly (non-electronic coin drops).

IMPORTANT: Never use oil to correct coin drop problems. Oil residue will prevent coins from rolling properly.

IMPORTANT: Do not bend or damage mechanical parts within coin drop.

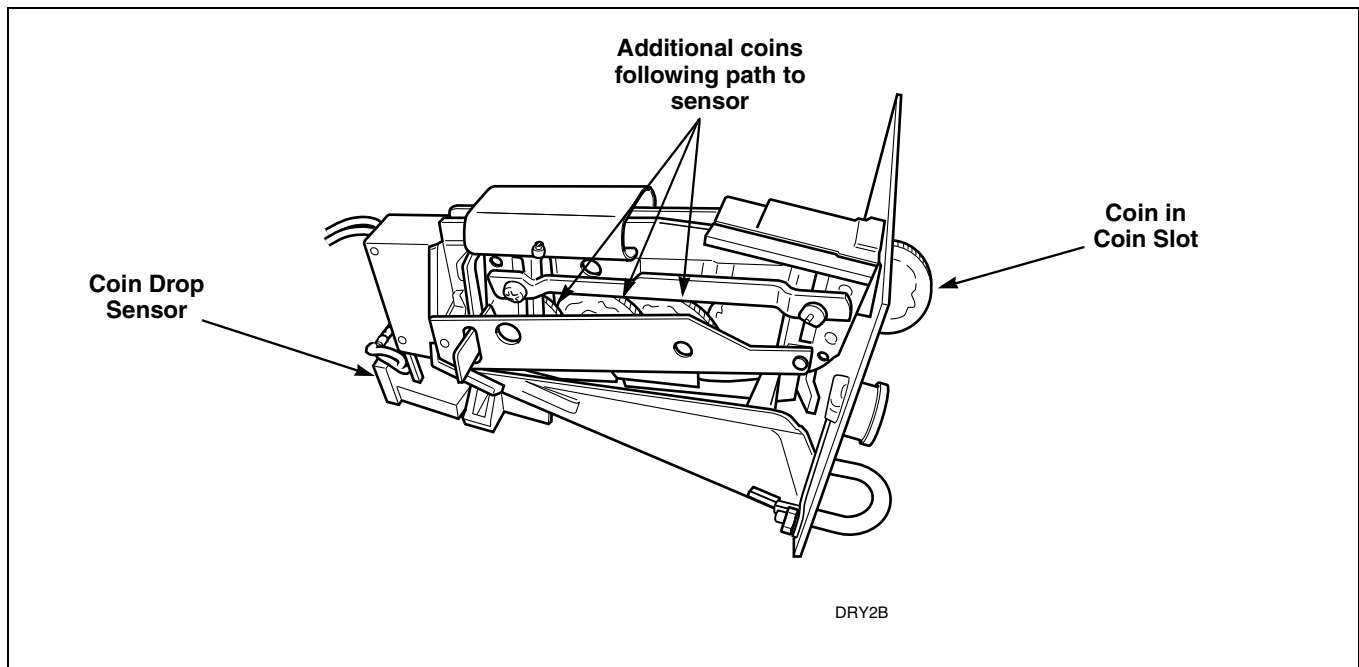

Figure 1



WARNING

To reduce the risk of electric shock, fire, explosion, serious injury or death:

- Disconnect electric power to the washer before servicing.
- Never start the washer with any guards/panels removed.
- Whenever ground wires are removed during servicing, these ground wires must be reconnected to ensure that the washer is properly grounded.
- Motor not grounded! Disconnect electric power before servicing motor.

W485

3. Troubleshooting Coin Drop (continued)

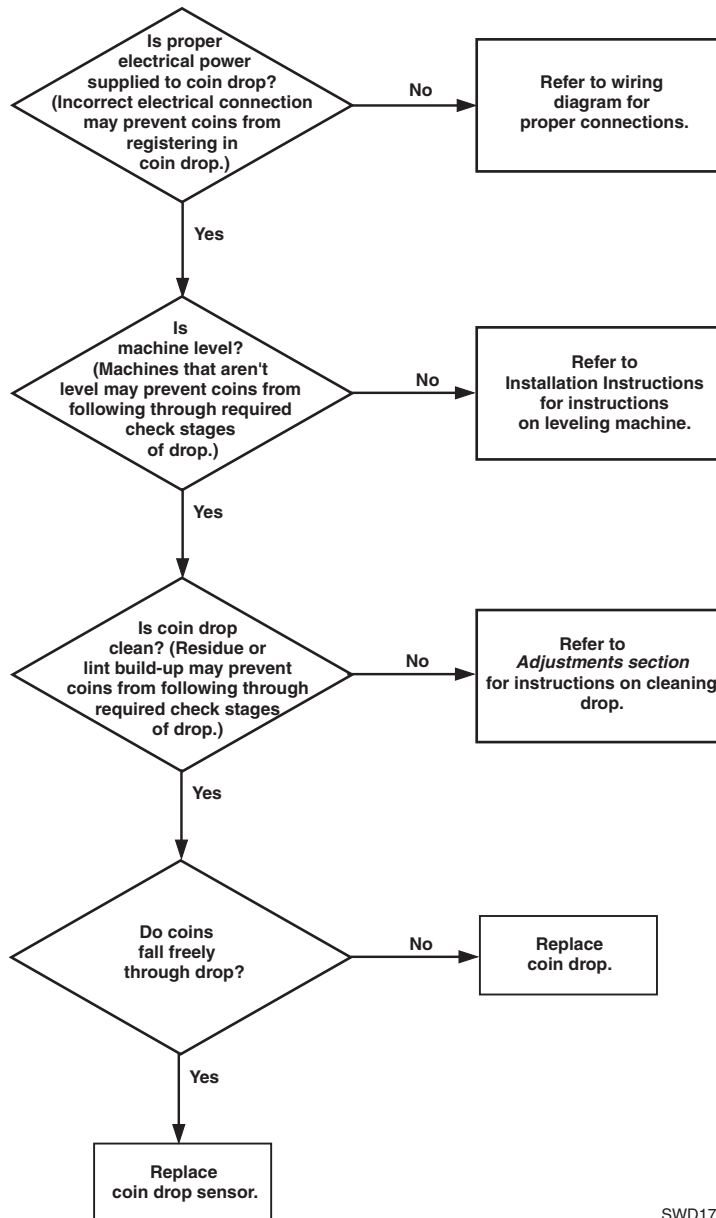

SWD1714S



WARNING

To reduce the risk of electric shock, fire, explosion, serious injury or death:

- Disconnect electric power to the washer before servicing.
- Never start the washer with any guards/panels removed.
- Whenever ground wires are removed during servicing, these ground wires must be reconnected to ensure that the washer is properly grounded.
- Motor not grounded! Disconnect electric power before servicing motor.

W485

b. Electronic Coin Drops:

If coin drop is not accepting coins, perform the following:

- (1) Clean coin drop. Refer to *Paragraph 40*.
- (2) On electronic coin drops with an old-style tension spring (shown in *Figure 2* and *Figure 4*), test and replace tension spring using the following instructions.

Remove Coin Drop From Machine

- (1) Disconnect electrical power to machine and drop.
- (2) Remove coin drop from machine.

Test Tension Spring

- (1) Push coin return button to open and close coin drop cover to clear possible coin jams. Refer to *Figure 2*.

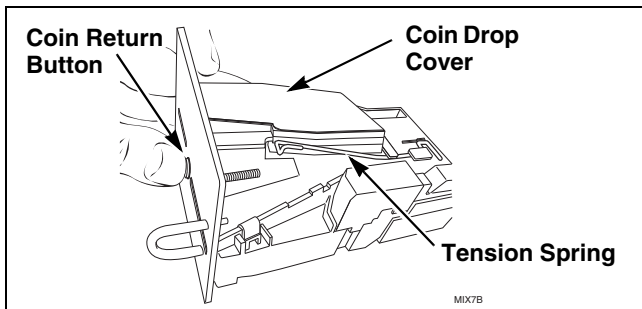

Figure 2

- (2) Manually hold down coin drop cover and insert coin. Refer to *Figure 3*.

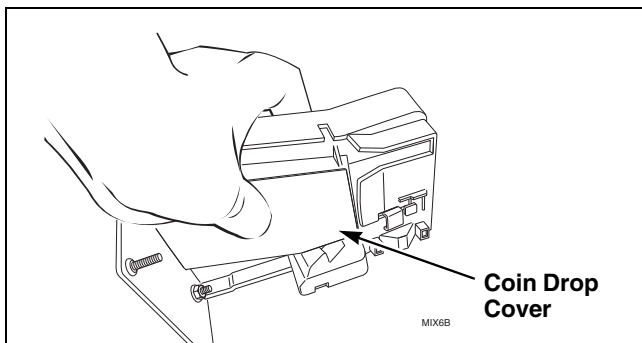

Figure 3

- (3) If coin drop now operates properly, replace tension spring using instructions on following pages.

Replace Tension Spring

- (1) Move tension spring downward until cover catch is free. Refer to *Figure 4*.

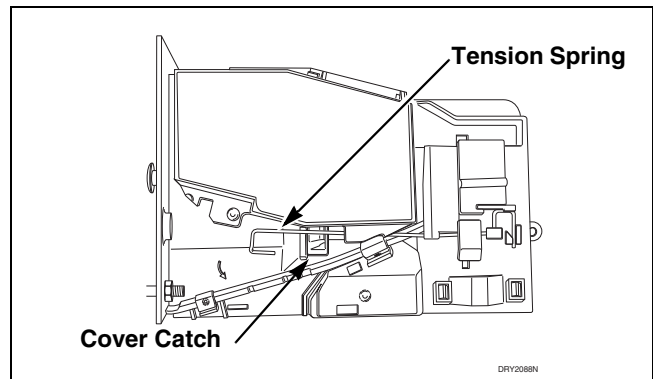

Figure 4

- (2) Open cover for coin drop.



WARNING

To reduce the risk of electric shock, fire, explosion, serious injury or death:

- Disconnect electric power to the washer before servicing.
- Never start the washer with any guards/panels removed.
- Whenever ground wires are removed during servicing, these ground wires must be reconnected to ensure that the washer is properly grounded.
- Motor not grounded! Disconnect electric power before servicing motor.

W485

- (3) Place a small flathead screwdriver under right side of tension spring and lift up. Refer to *Figure 5*.

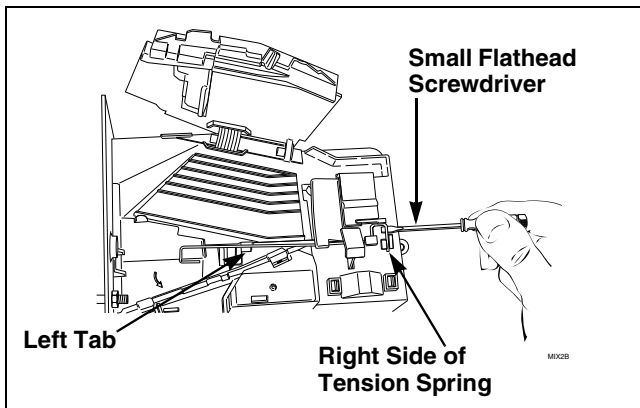

Figure 5

- (4) Use screwdriver to move spring approximately 3 mm to left.
 (5) Lift spring over left tab. Refer to *Figure 5*.
 (6) Rotate spring clockwise, 40 to 60 degrees, until it is free from right tabs. Refer to *Figure 6*.

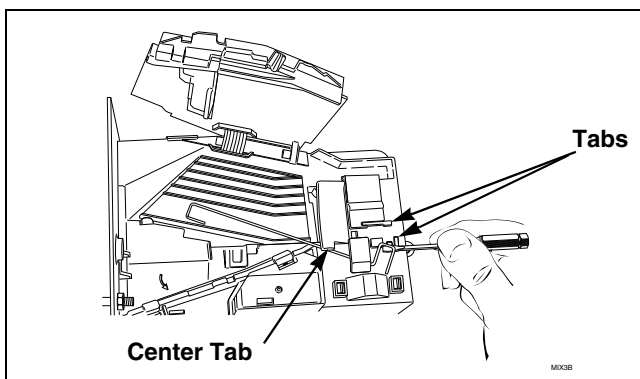

Figure 6

- (7) Use screwdriver to remove spring from center tab. Refer to *Figure 6*.
 (8) Lift spring, with attached clip, off drop.

- (9) Remove clip from spring. Refer to *Figure 7*.

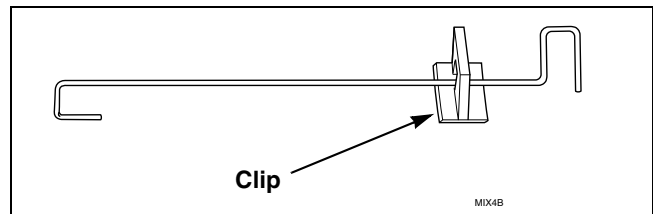

Figure 7

- (10) Attach clip to new tension spring, Part No. 209/00598/02.
 (11) Place clip, installed on spring, in slot on coin drop. Refer to *Figure 8*.

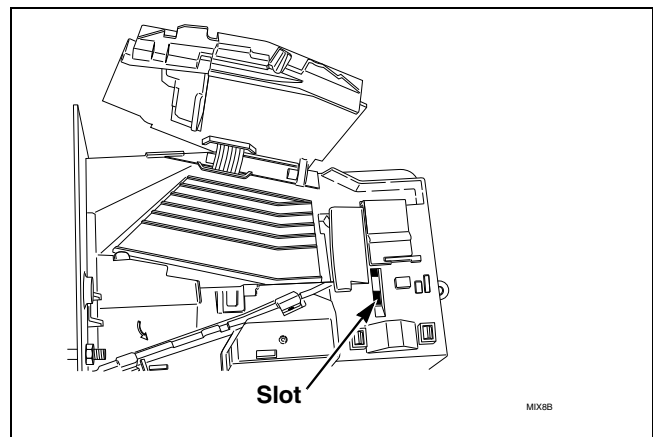

Figure 8



WARNING

To reduce the risk of electric shock, fire, explosion, serious injury or death:

- Disconnect electric power to the washer before servicing.
- Never start the washer with any guards/panels removed.
- Whenever ground wires are removed during servicing, these ground wires must be reconnected to ensure that the washer is properly grounded.
- Motor not grounded! Disconnect electric power before servicing motor.

W485

- (12) Use a small flathead screwdriver to push spring under center tab. Refer to *Figure 9*.

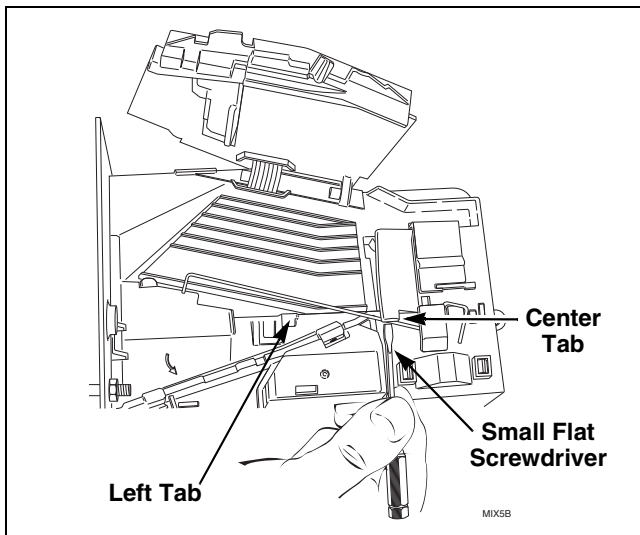

Figure 9

- (13) Lift spring gently to place in position under left tab.
- (14) Push spring to right until it snaps into position. Refer to *Figure 5*.
- (15) Close coin drop cover.
- (16) Move tension spring over cover catch. Refer to *Figure 4*.

Reinstall Coin Drop Into Machine

- (1) Reinstall coin drop into machine.
- (2) Reconnect electrical power to machine and drop.
- (3) Add a coin to drop to verify that coin drop is operating properly and that electrical connection is working properly.



WARNING

To reduce the risk of electric shock, fire, explosion, serious injury or death:

- Disconnect electric power to the washer before servicing.
- Never start the washer with any guards/panels removed.
- Whenever ground wires are removed during servicing, these ground wires must be reconnected to ensure that the washer is properly grounded.
- Motor not grounded! Disconnect electric power before servicing motor.

W485

4. No Spin Due to Out-of-Balance Switch Wiring Problem Starting Serial Nos. Beginning 0307

A “no spin” condition could be the result of an open circuit in the wire harness or out-of-balance switch. First, check that the harness is still connected to the out-of-balance switch. The out-of-balance switch is a **normally closed switch**. (continued)

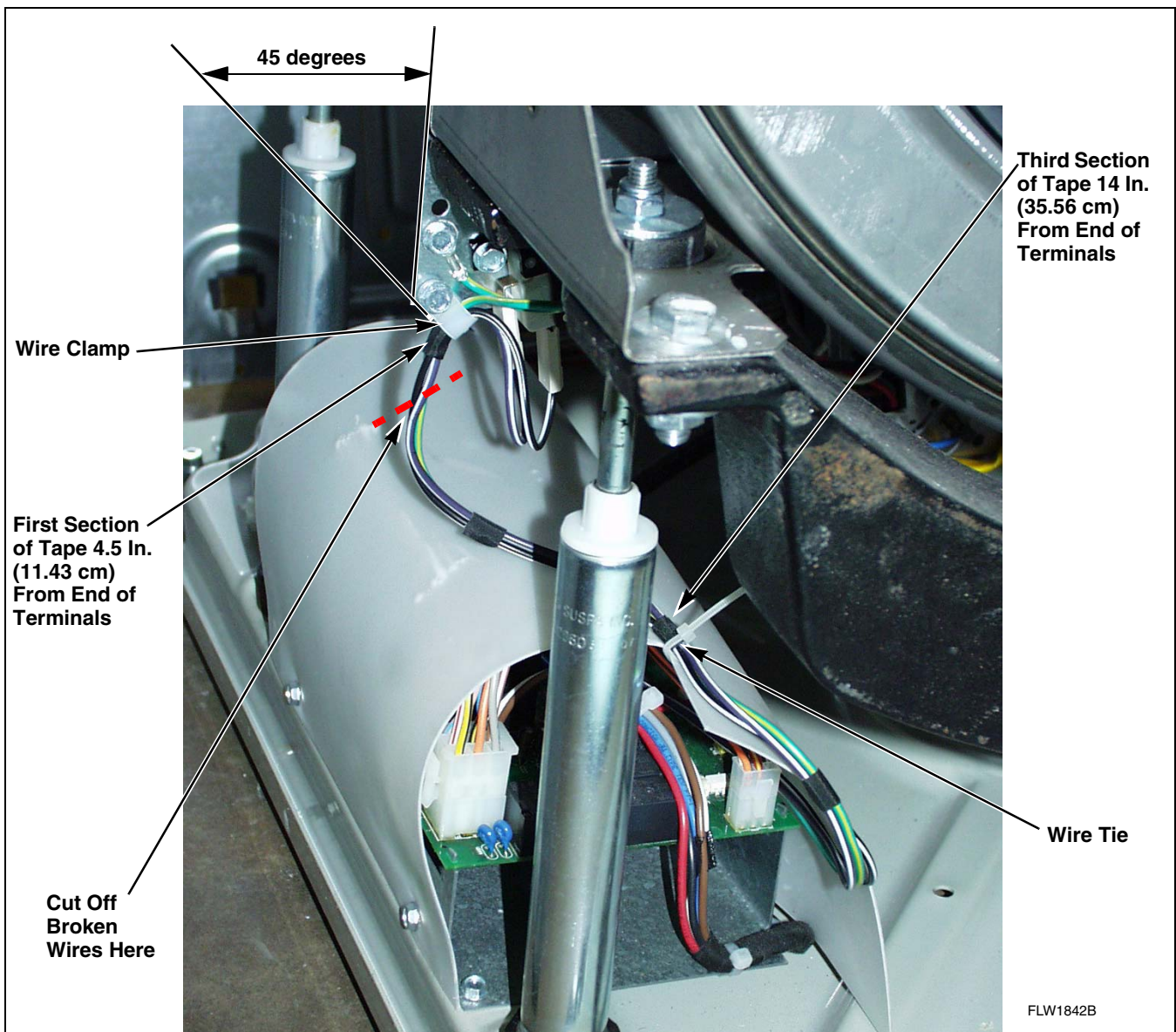

Figure 10



WARNING

To reduce the risk of electric shock, fire, explosion, serious injury or death:

- Disconnect electric power to the washer before servicing.
- Never start the washer with any guards/panels removed.
- Whenever ground wires are removed during servicing, these ground wires must be reconnected to ensure that the washer is properly grounded.
- Motor not grounded! Disconnect electric power before servicing motor.

W485

If broken wires are found at the out-of-balance switch wire support, cut off portion of wires as shown in *Figure 10* and add new UL approved terminals.

- a. To test the electrical circuit, disconnect electrical power to the washer.
- b. Remove the “H1” connector from the inverter control assembly.
- c. Use an Ohm meter to check the black/white to violet/white wires. Circuit should read closed. An open reading indicates a bad switch or wire harness problem.
- d. Flex the harness at the plastic wire clamp and test continuity. If the base wire harness has an open circuit it **MUST** be replaced or the broken wires must be repaired with UL approved terminals.
- e. After replacing or repairing the wire harness, wrap electrical tape around wires in two locations as indicated below and in *Figure 10*. Then secure the harness wires to the original factory locations using clamp and wire tie. Refer to *Figure 10*.
 - (1) The plastic wire clamp should be angled toward the switch at 45 degrees.
 - (2) The clamp should wrap around the first section of tape on the harness, which should be placed approximately 4.5 inches (11.43 cm) from end of terminals.
 - (3) The harness should be secured to the inverter control shield with a wire tie.
 - (4) The tie should wrap around the third section of tape on the harness, which should be placed approximately 14 inches (35.56 cm) from end of terminals. Refer to *Figure 10*.

5. Troubleshooting LEDs on Inverter Controls Starting Machine Serial No. 0911014603

There are three LEDs on the control to assist with troubleshooting (refer to *Figure 11*):

- Green LED on constant = 5VDC power supply present
- Green LED flashing one second on/one second off = inverter control power up
- Red LED flashing four times/second = inverter control is communicating with front end control

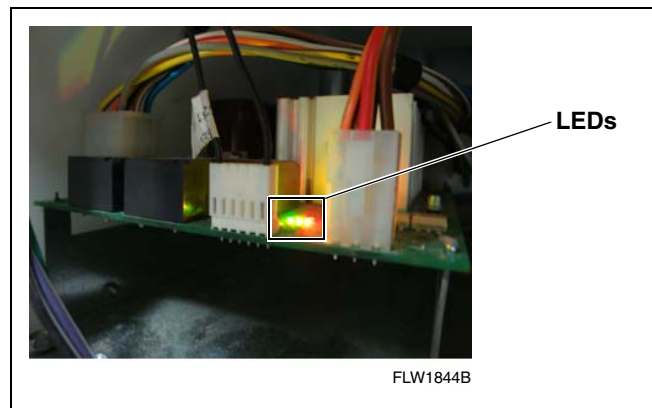



Figure 11

6. Vibration

If frontload washer vibrates or shakes, refer to additional leveling procedure in *Paragraph 34*.

	WARNING
<p>To reduce the risk of electric shock, fire, explosion, serious injury or death:</p> <ul style="list-style-type: none"> • Disconnect electric power to the washer before servicing. • Never start the washer with any guards/panels removed. • Whenever ground wires are removed during servicing, these ground wires must be reconnected to ensure that the washer is properly grounded. • Motor not grounded! Disconnect electric power before servicing motor. 	
W485	

7. No Spin

A no spin condition is not caused by intermittent operation of the motor or motor control (inverter assembly). **DO NOT** replace these components for no spin complaints if the unit passes the following procedure:

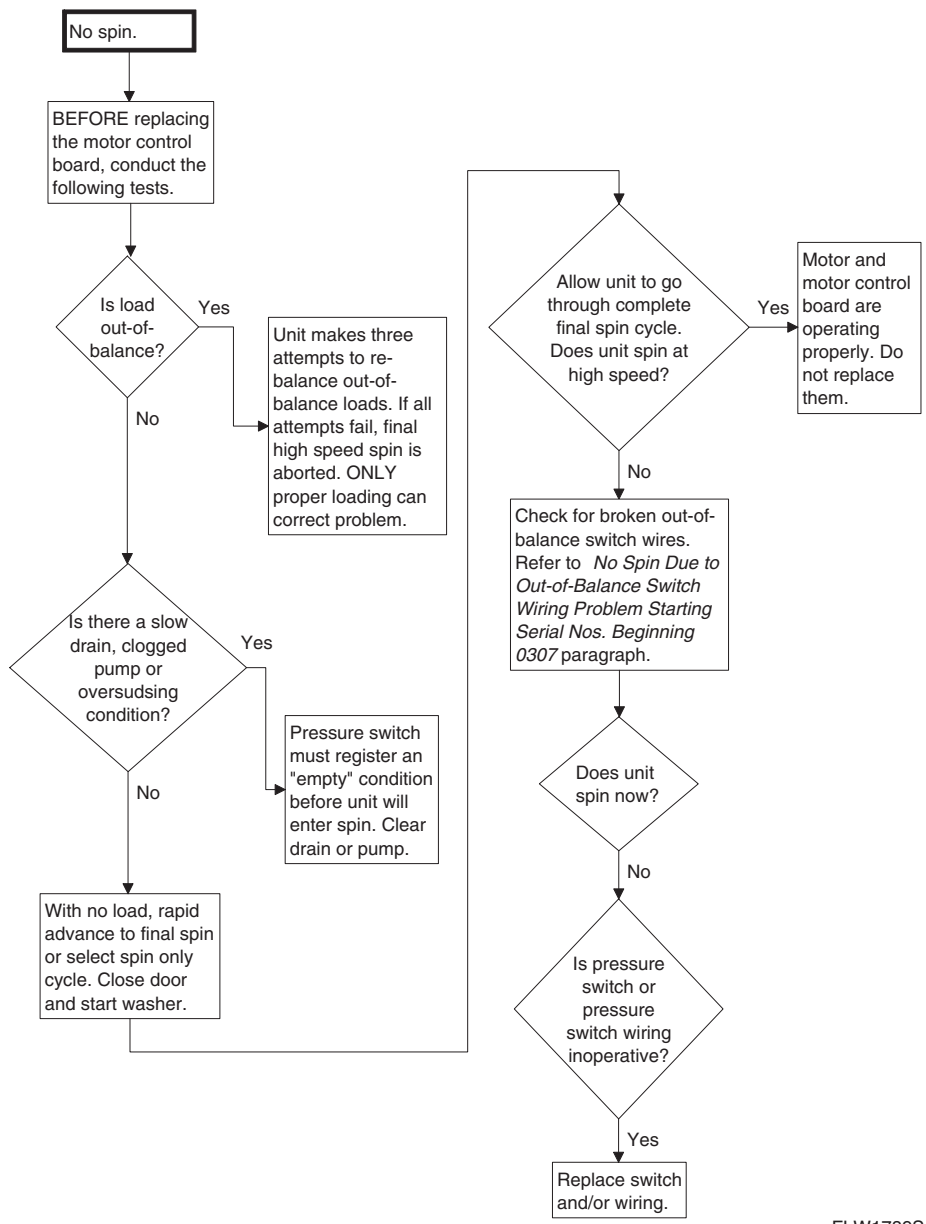

FLW1789S

Section 4

Coin Slide Operated Troubleshooting



WARNING

To reduce the risk of electric shock, fire, explosion, serious injury or death:

- Disconnect electric power to the washer before servicing.
- Never start the washer with any guards/panels removed.
- Whenever ground wires are removed during servicing, these ground wires must be reconnected to ensure that the washer is properly grounded.
- Motor not grounded! Disconnect electric power before servicing motor.

W485

8. Coin Slide Can't Be Fully Inserted

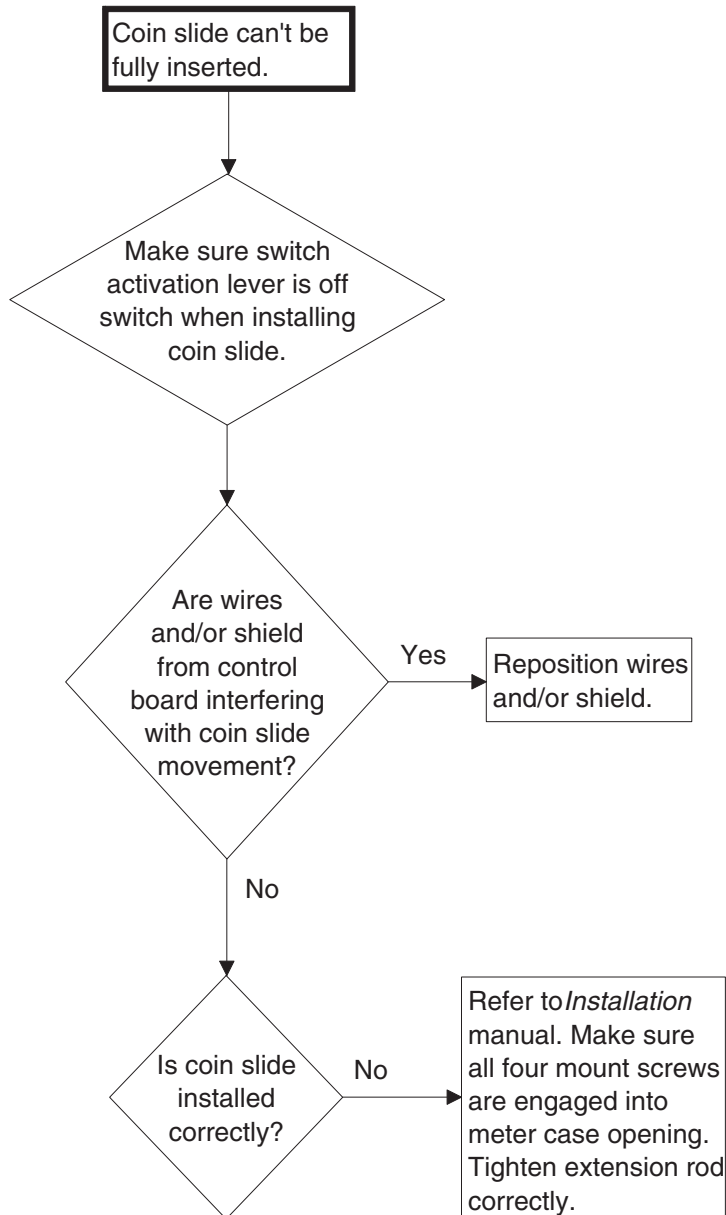

TLW1836B

9. Coin Slide Switch Not Activated

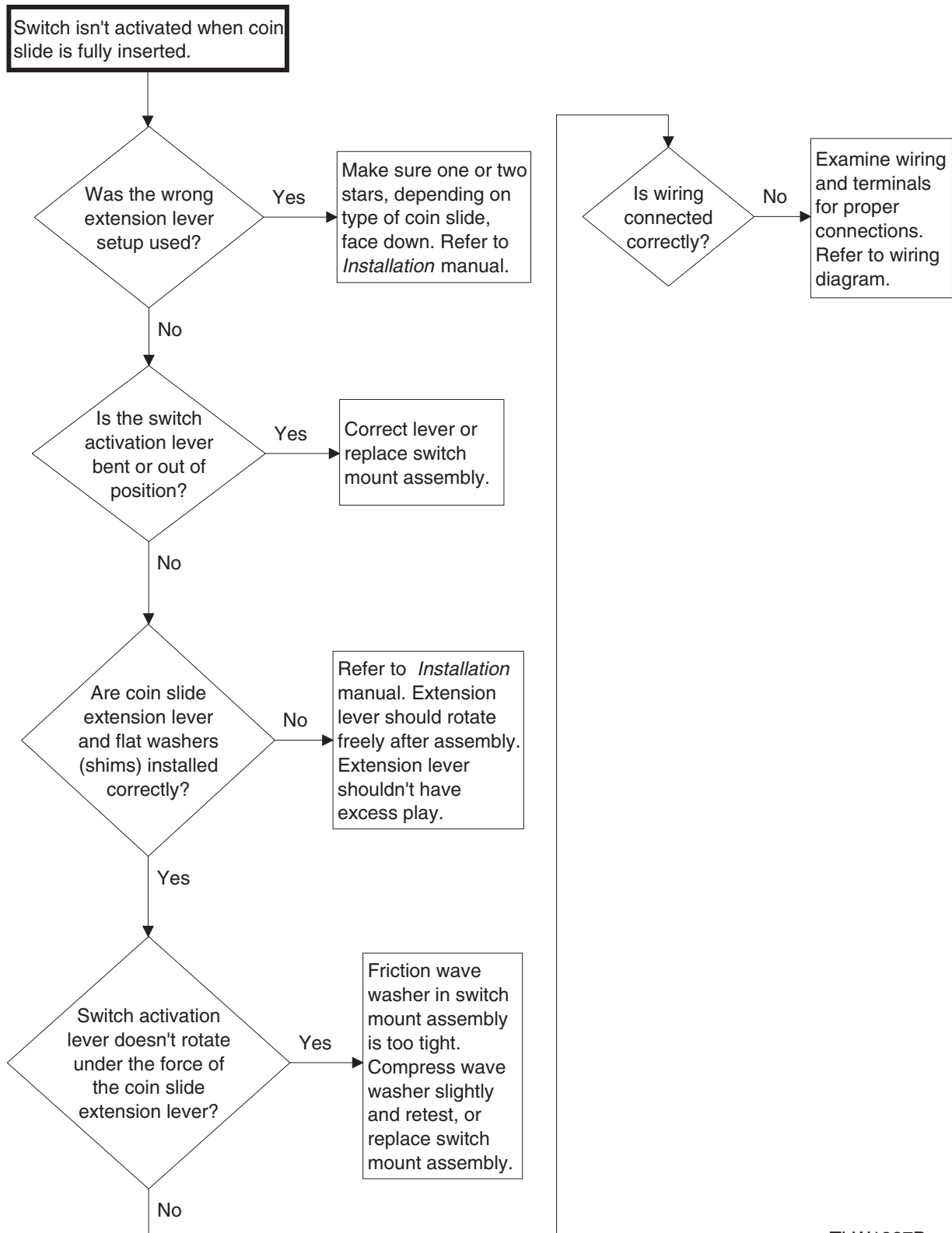

TLW1837B

10. Coin Slide Switch Activated Too Soon

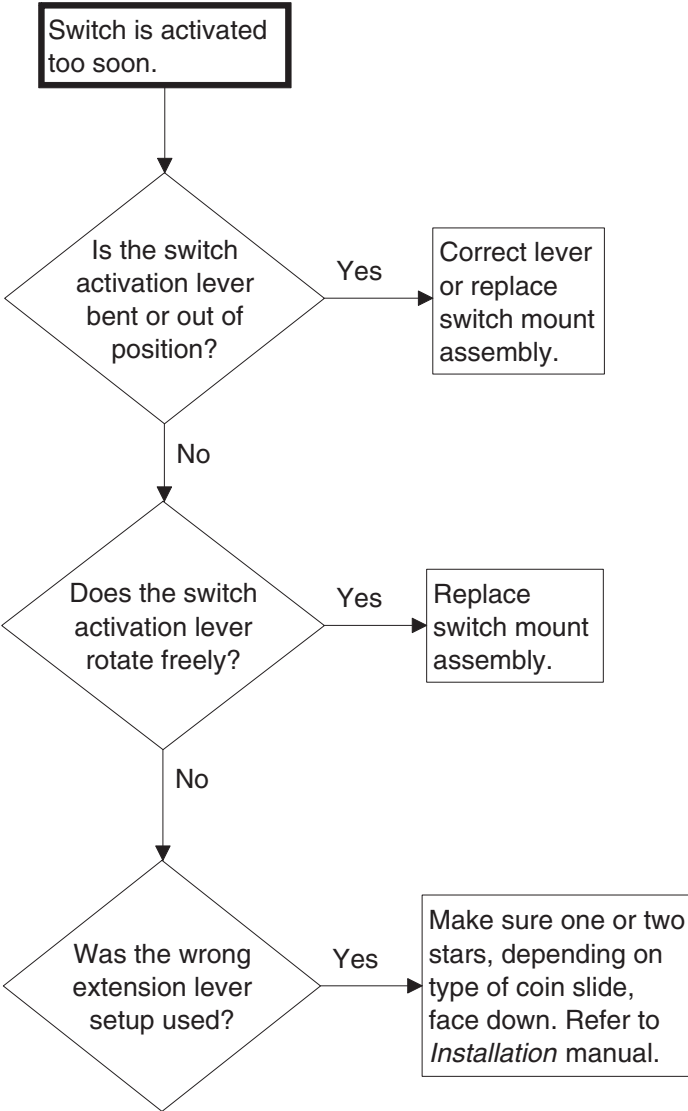

TLW1838B

11. Coin Slide Doesn't Freely Return

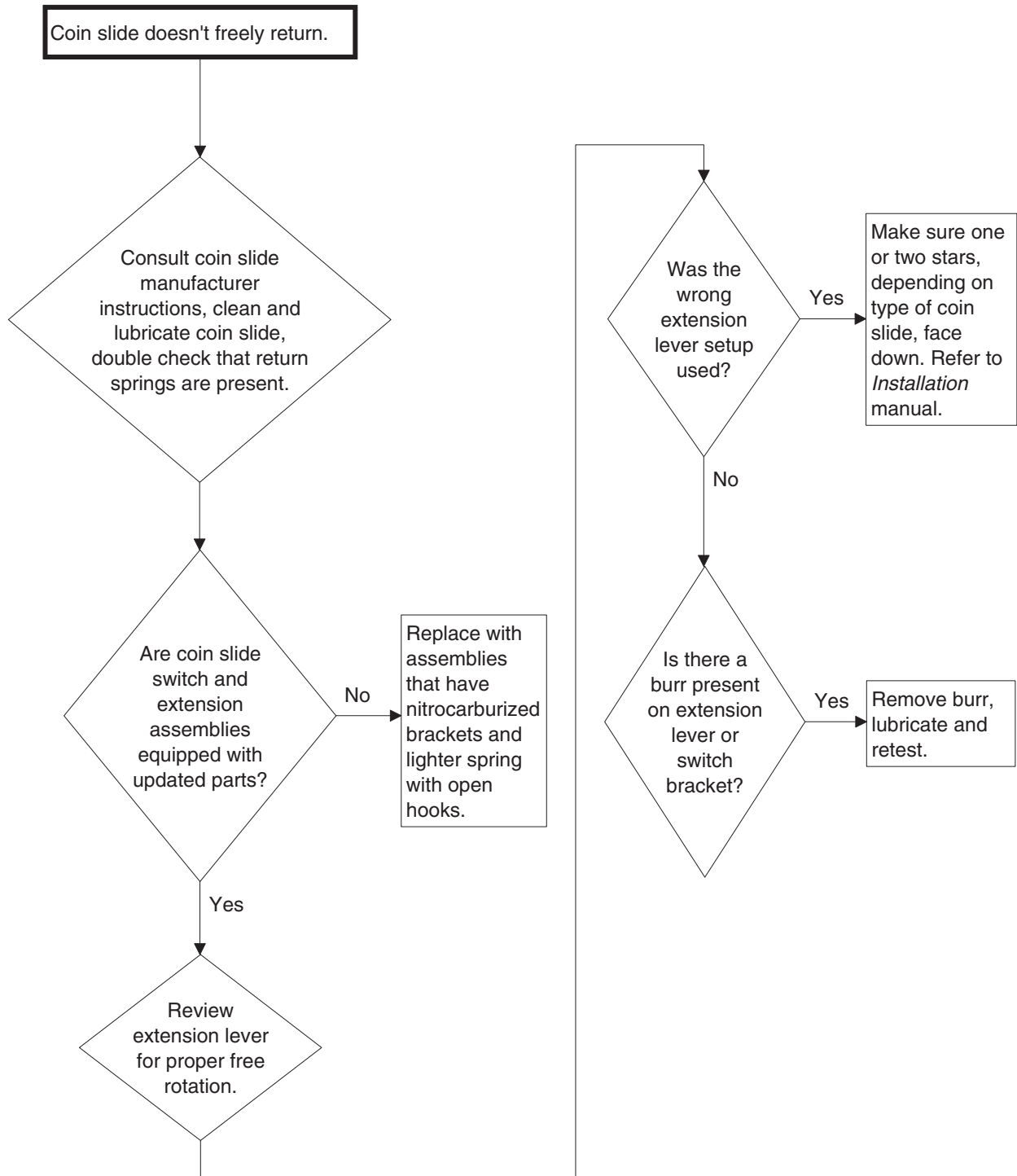

TLW1839B

12. Error Code Listing

If any of the following errors occur, the control enters Error Mode. For all fatal errors, the control will terminate the current cycle, turn off all

outputs, and flash two LEDs one second on/one second off to indicate the error. Refer to the chart below for which lights flash for each error.

<p>DOOR LOCKED and FINAL SPIN AND TUMBLE LEDs flashing (Motor Failure Error)</p>	<p>If the control receives the motor failure signal from the motor control, the control will enter Error Mode. The control will turn off all outputs and flash the DOOR LOCKED and FINAL SPIN AND TUMBLE LEDs one second on/one second off to indicate a motor failure error. This is a fatal error. The machine must be unpowered to clear this error.</p>
<p>IN USE and DOOR LOCKED LEDs flashing (Fill Error)</p>	<p>If the control receives no full input from the pressure switch indicating the cylinder is full within 30 minutes of starting the fill, the control will enter Error Mode. The control will turn off all outputs and flash the IN USE and DOOR LOCKED LEDs one second on/one second off to indicate a fill error. This is a fatal error. The machine must be unpowered to clear this error.</p>
<p>IN USE and CLOSE DOOR LEDs flashing (Door Open Error)</p>	<p>If the control senses the door open during Run Mode, the control will enter Error Mode. The control will turn off all outputs and flash the IN USE and CLOSE DOOR LEDs one second on/one second off to indicate a door open error. This is a fatal error. The machine must be unpowered to clear this error.</p>
<p>DOOR LOCKED and CLOSE DOOR LEDs flashing (Door Lock/Unlock Error)</p>	<p>If the door doesn't lock in 15 seconds in Door Locking Mode or the door doesn't unlock in 3 minutes in Door Unlocking Mode, the control will enter Door Lock Error Mode. The control will turn off all outputs and flash the DOOR LOCKED and CLOSE DOOR LEDs one second on/one second off to indicate a door lock/unlock error.</p> <p>To clear this error in Door Locked Mode the door must either open or lock. If the door locks, the cycle will start normally. If the door opens, the control will revert back to Start Mode.</p> <p>To clear this error in Door Unlocking Mode the door must unlock or open. If the door unlocks or opens, the control will enter End of Cycle Mode.</p>
<p>FINAL SPIN AND TUMBLE and CLOSE DOOR LEDs flashing (SPI Communications Error)</p>	<p>This error occurs when there is a problem with communications between the front-end control and the motor control. The control will turn off all outputs and flash the FINAL SPIN AND TUMBLE and CLOSE DOOR LEDs one second on/one second off to indicate an SPI communications error. This is a fatal error. The machine must be powered down at this point.</p>

13. Washer Will Not Start – No LEDs/Lights Lit (No Response to Start Switch)

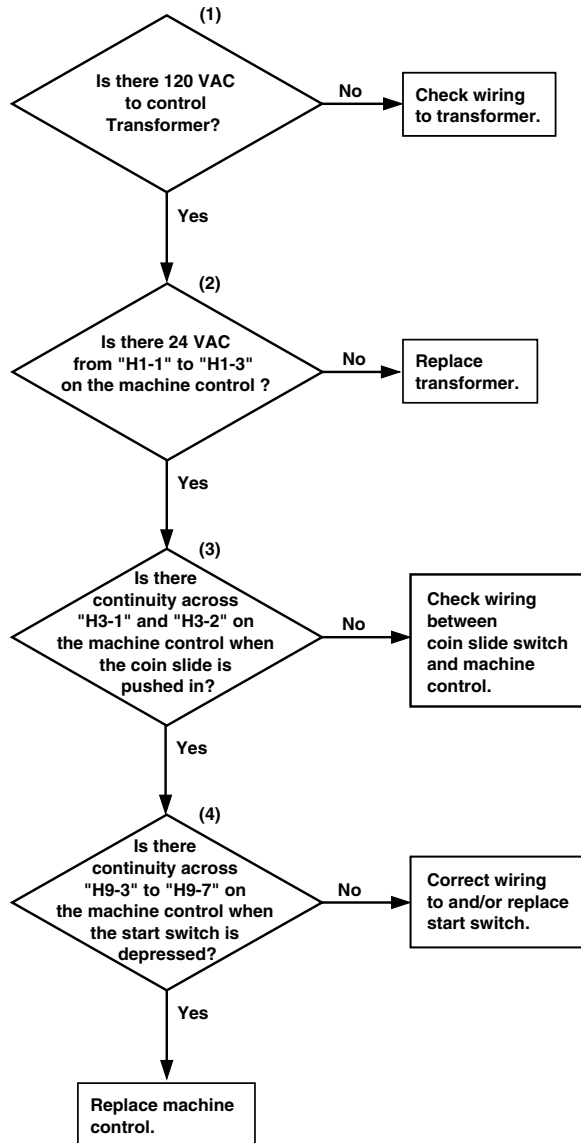

FLW1725S

Washer Will Not Start – No LEDs/Lights Lit (No Response to Start Switch)

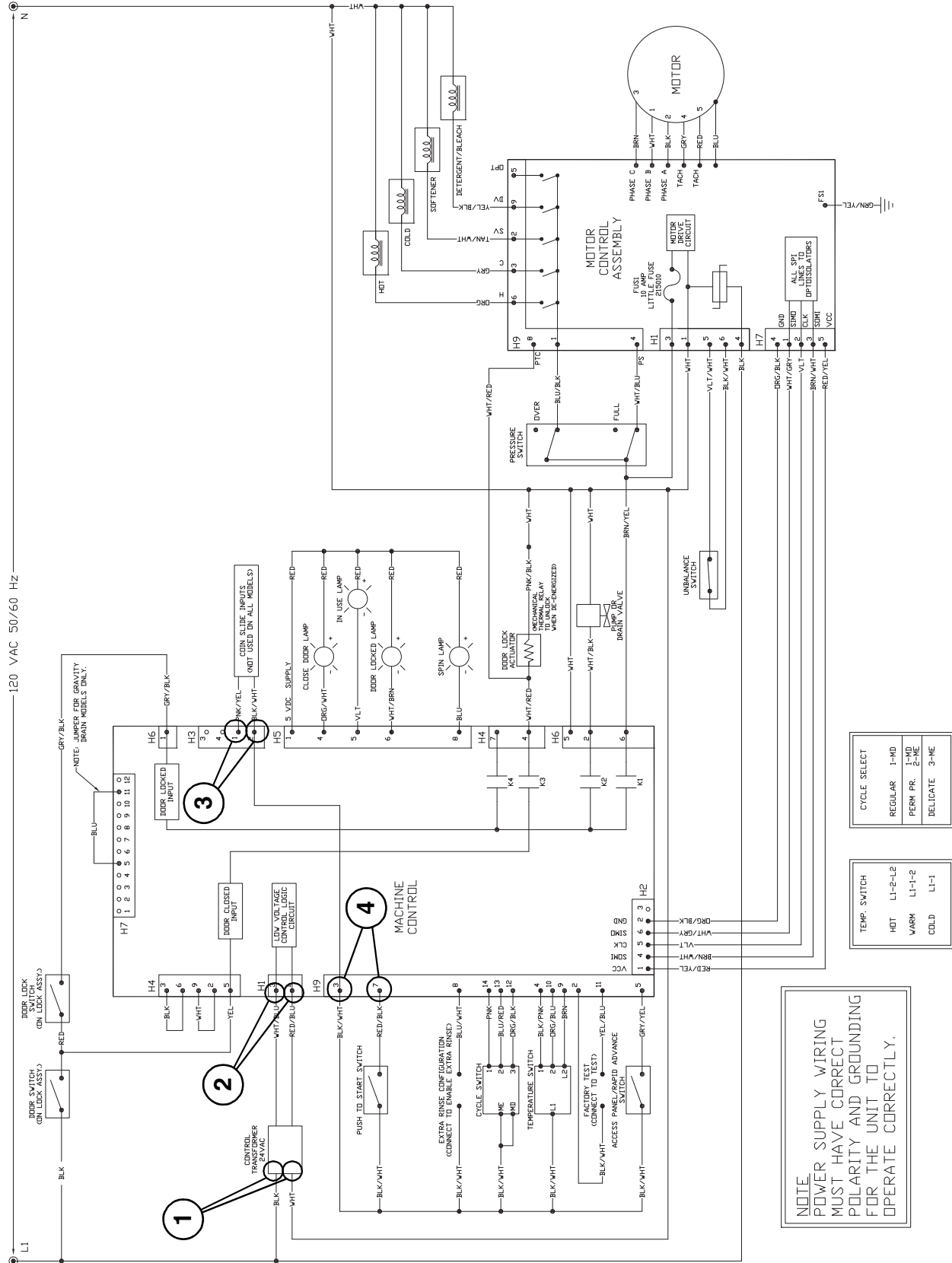

14. Washer Will Not Start – No Door Lock (Door Locked/Close Door LEDs Flashing)

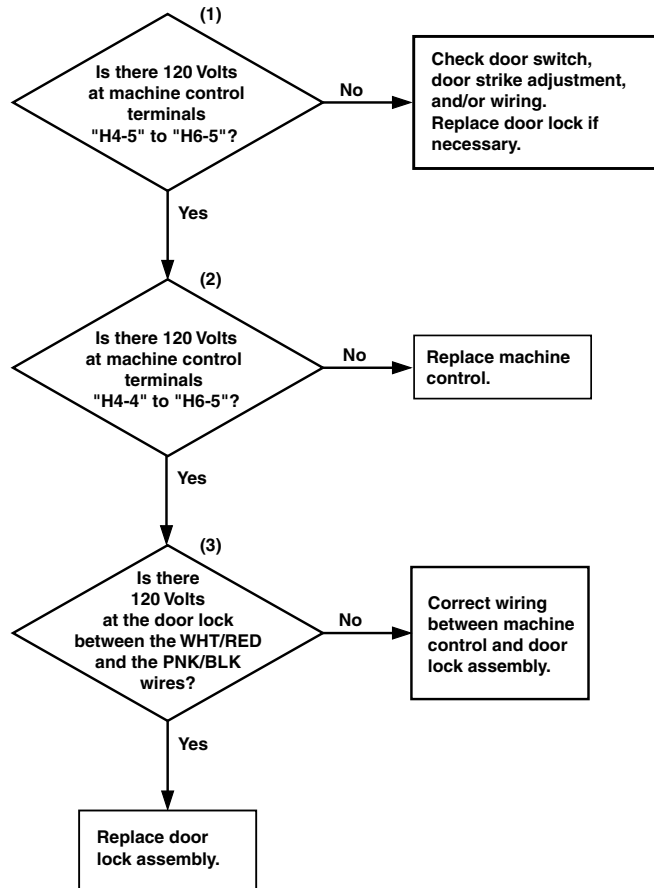

FLW1778S

Washer Will Not Start – No Door Lock (Door Locked/Close Door LEDs Flashing)

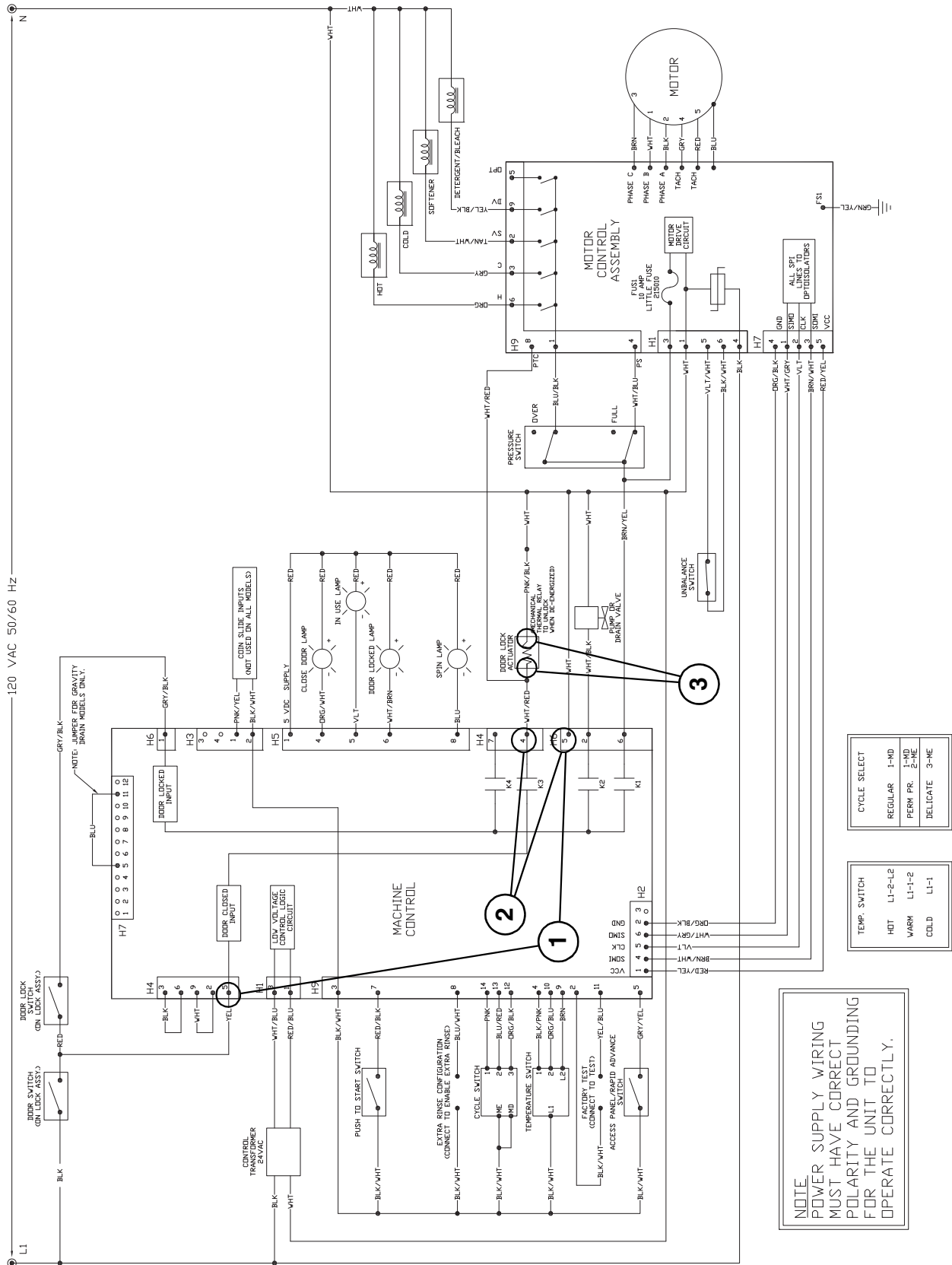

15. Washer Will Not Start – In Use/Close Door LEDs Flashing (Door Must Be Closed and Attempting to Lock)

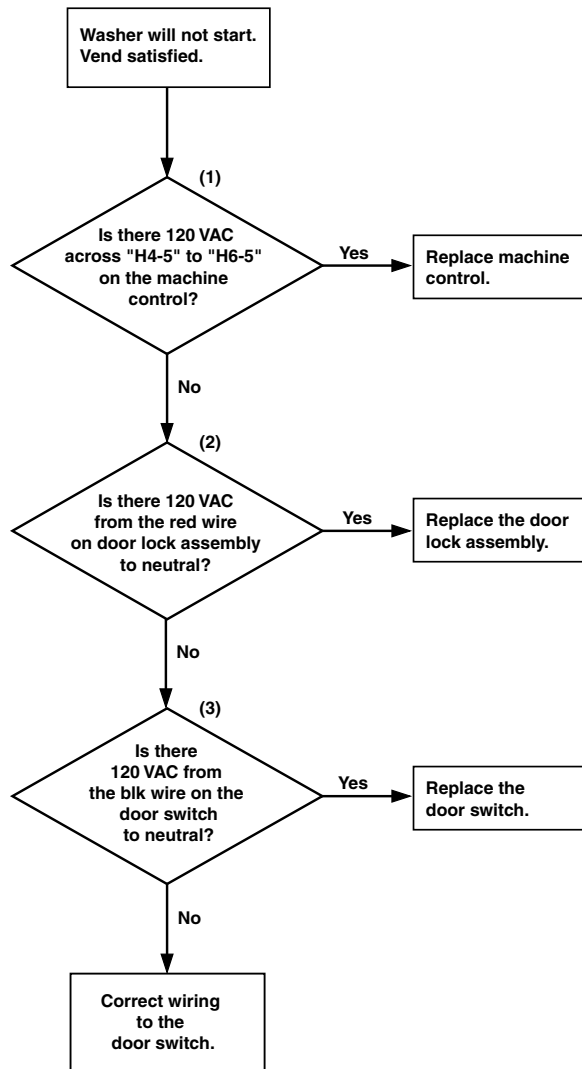

FLW1769S

Washer Will Not Start – In Use/Close Door LEDs Flashing (Door Must Be Closed and Attempting to Lock)

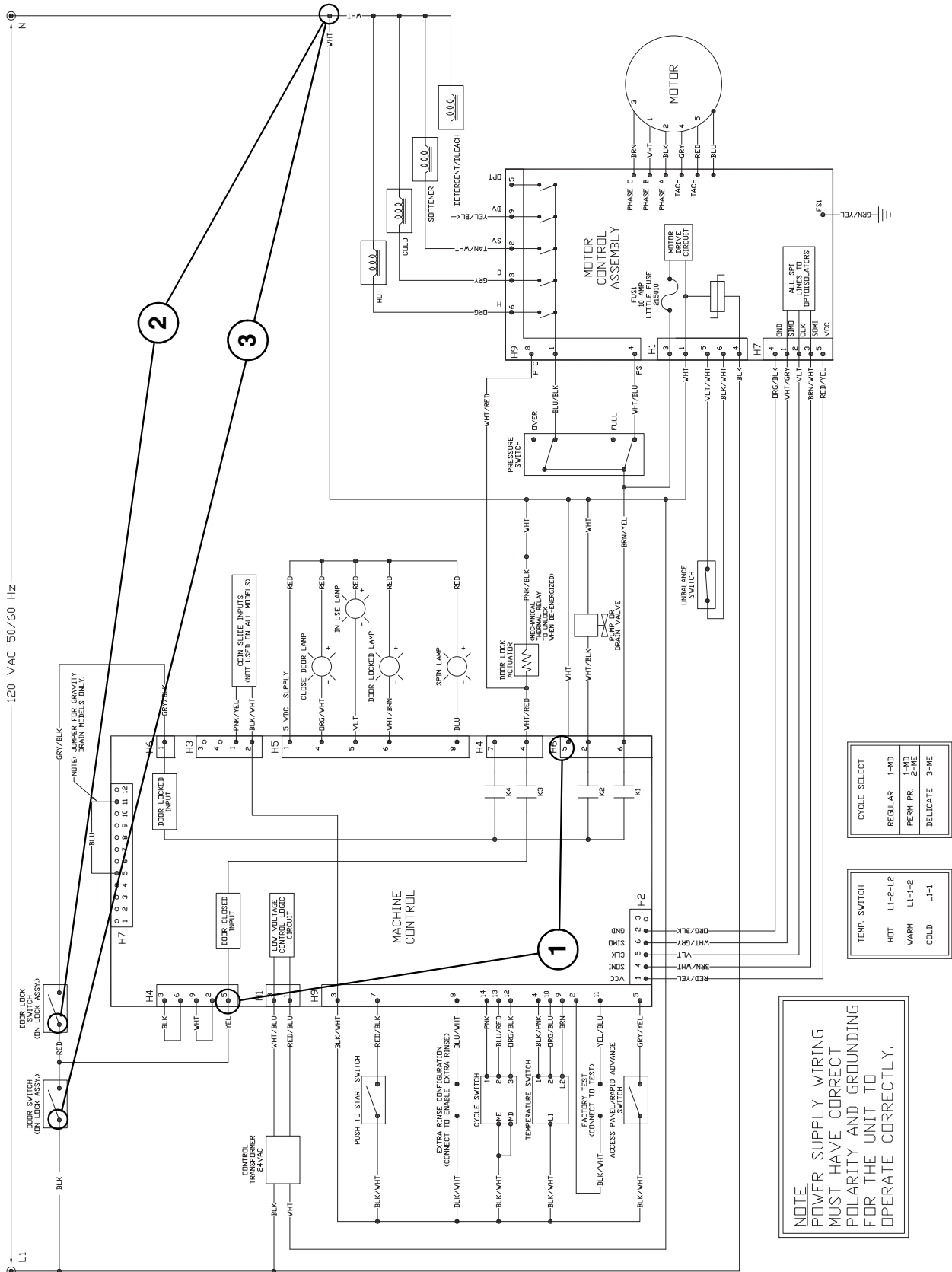

16. Motor Will Not Run (Door Locked/Final Spin and Tumble LEDs Flashing)

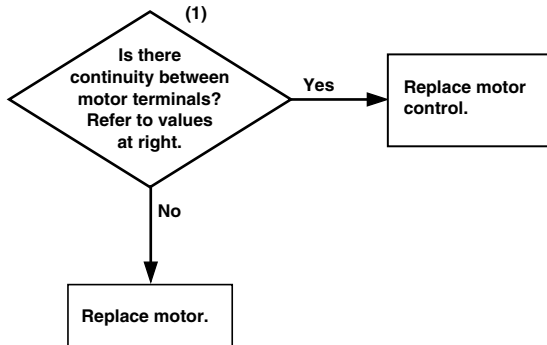

Motor Resistance Values:
Tach. Circuit: Approx. 115 ohms (Terminals 4-5)
Windings: Approx. 4 - 5 ohms (Terminals 1-2, 1-3, 2-3)

FLW1712S

Motor Will Not Run (Door Locked/Final Spin and Tumble LEDs Flashing)

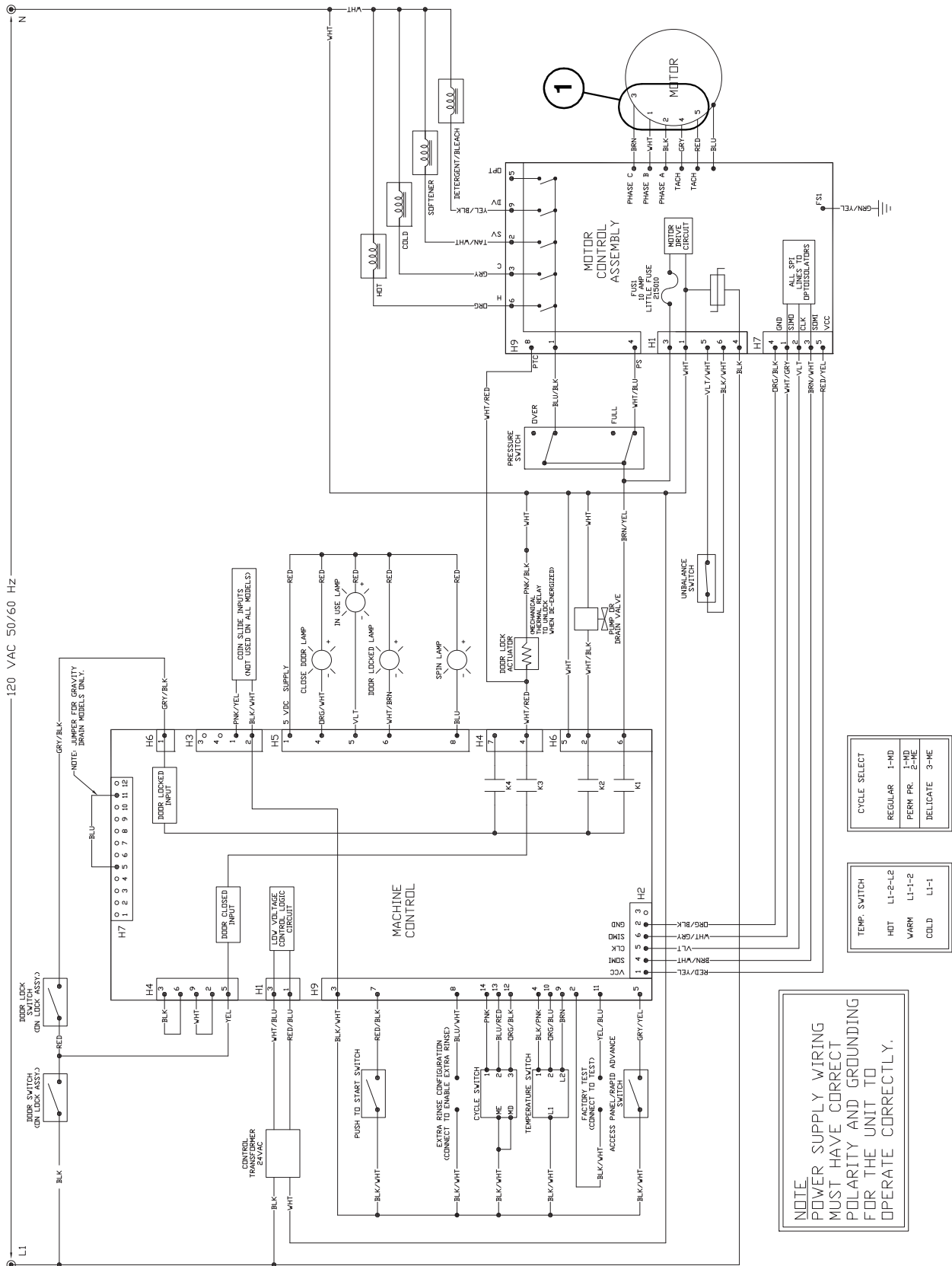

17. Washer Will Not Fill (In Use/Door Locked LEDs Flashing)

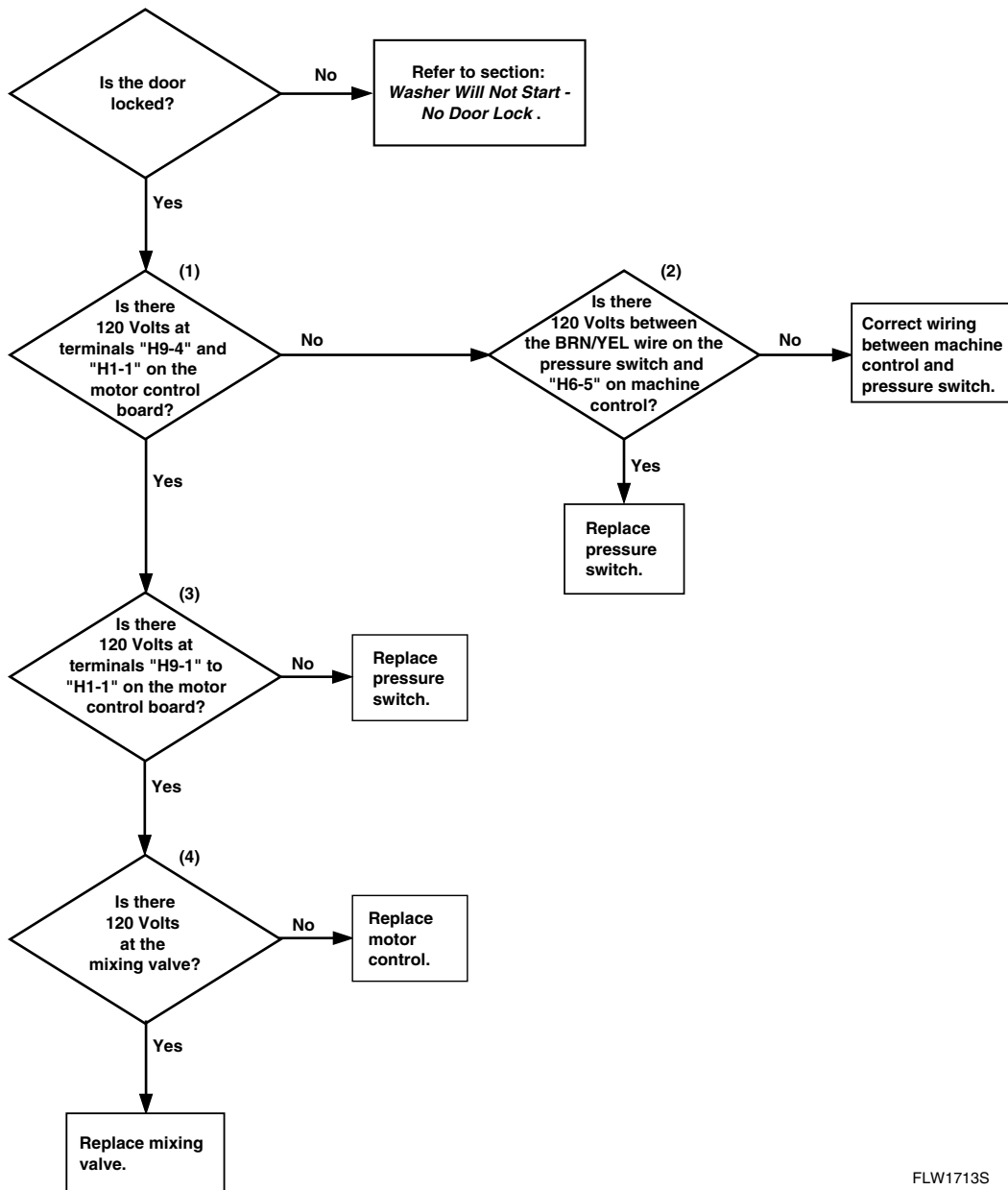

FLW1713S

Washer Will Not Fill (In Use/Door Locked LEDs Flashing)

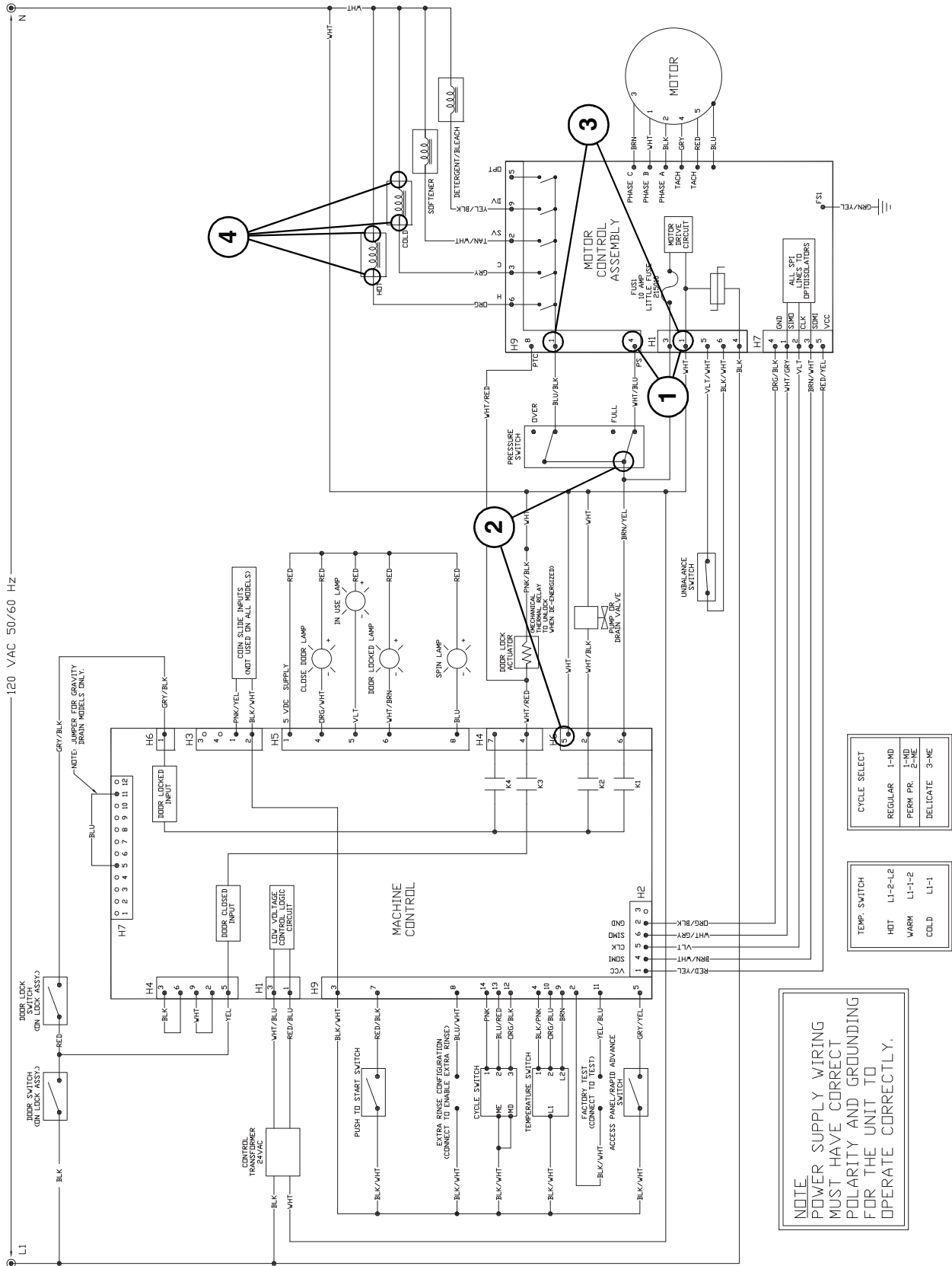

18. Washer Overflows

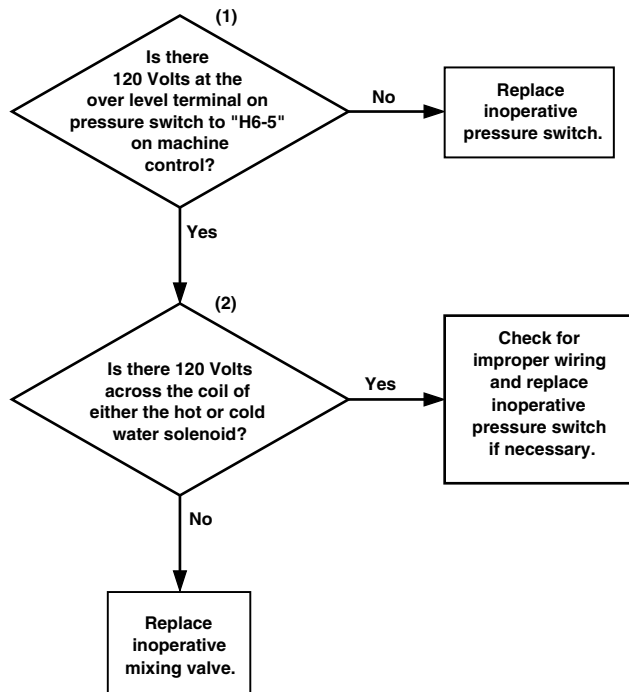

FLW1665S

Washer Overflows

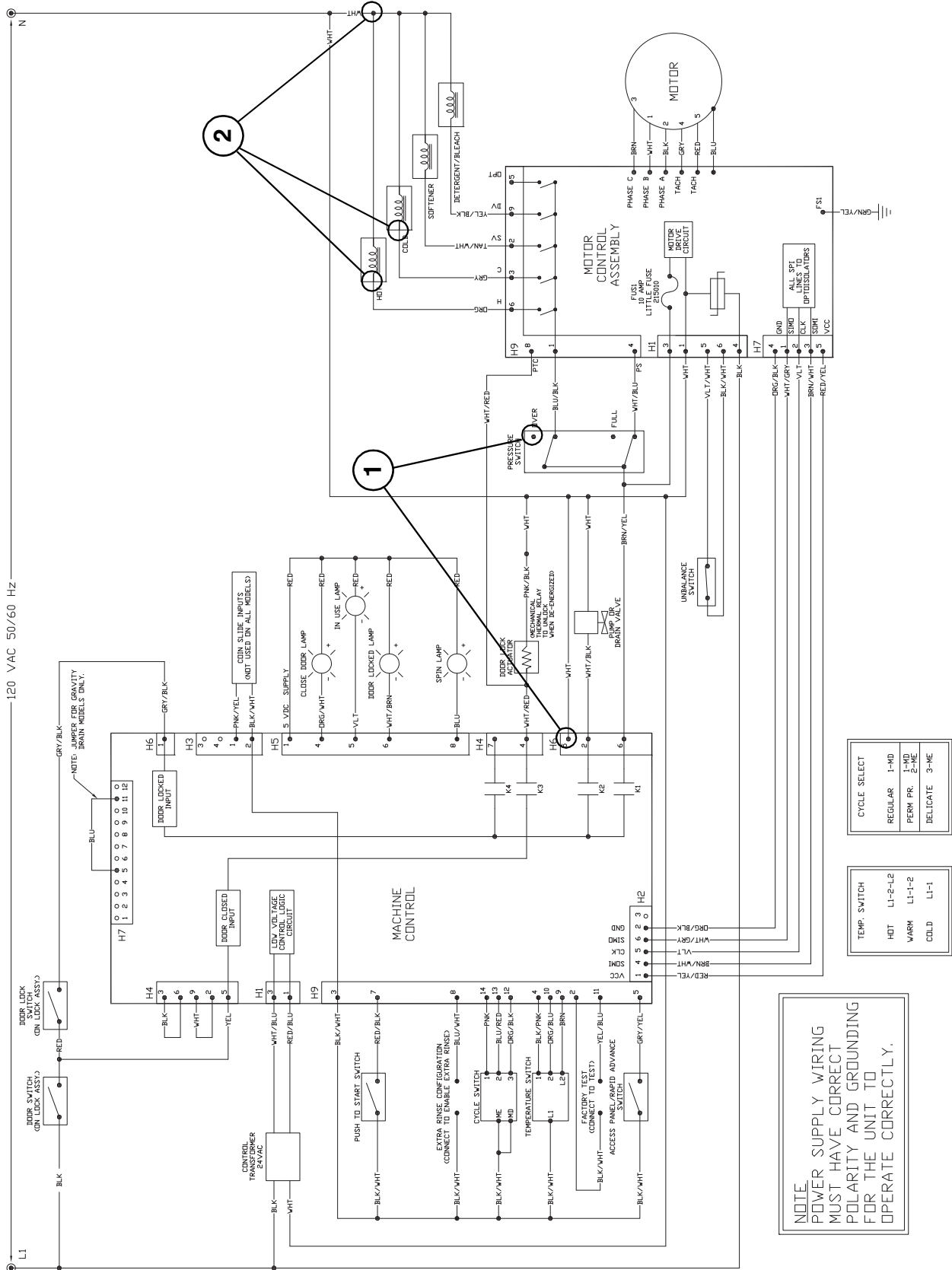

CYCLE SELECT	
REGULAR	1-MD
PERM FR.	2-WE
DELICATE	3-ME

TEMP. SWITCH	
HDT	L1-2-L2
WARM	L1-1-2
COLD	L1-1

NOTE
POWER SUPPLY WIRING
MUST HAVE CORRECT
POLARITY AND GROUNDING
FOR THE UNIT TO
OPERATE CORRECTLY.

19. Pump or Drain Valve Does Not Operate

NOTE: Check at beginning of spin/drain portion of cycle.

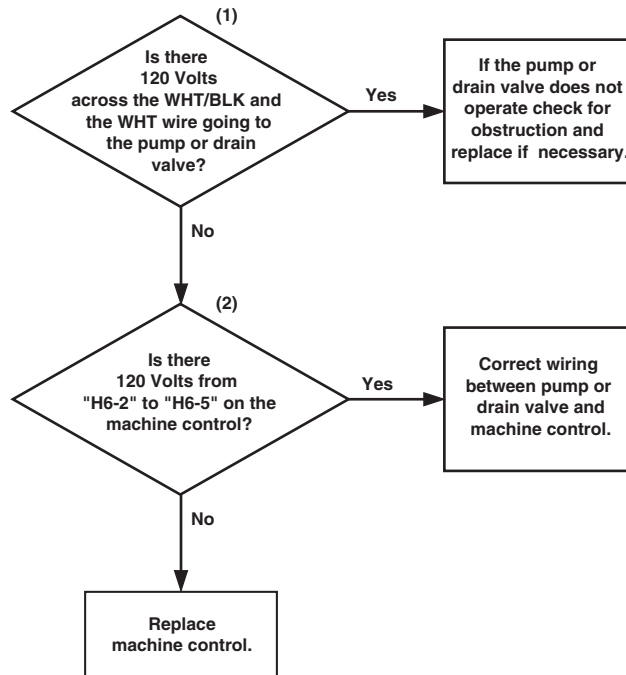

FLW1666S

20. Serial Communication Error (Final Spin and Tumble/Close Door LEDs Flashing)

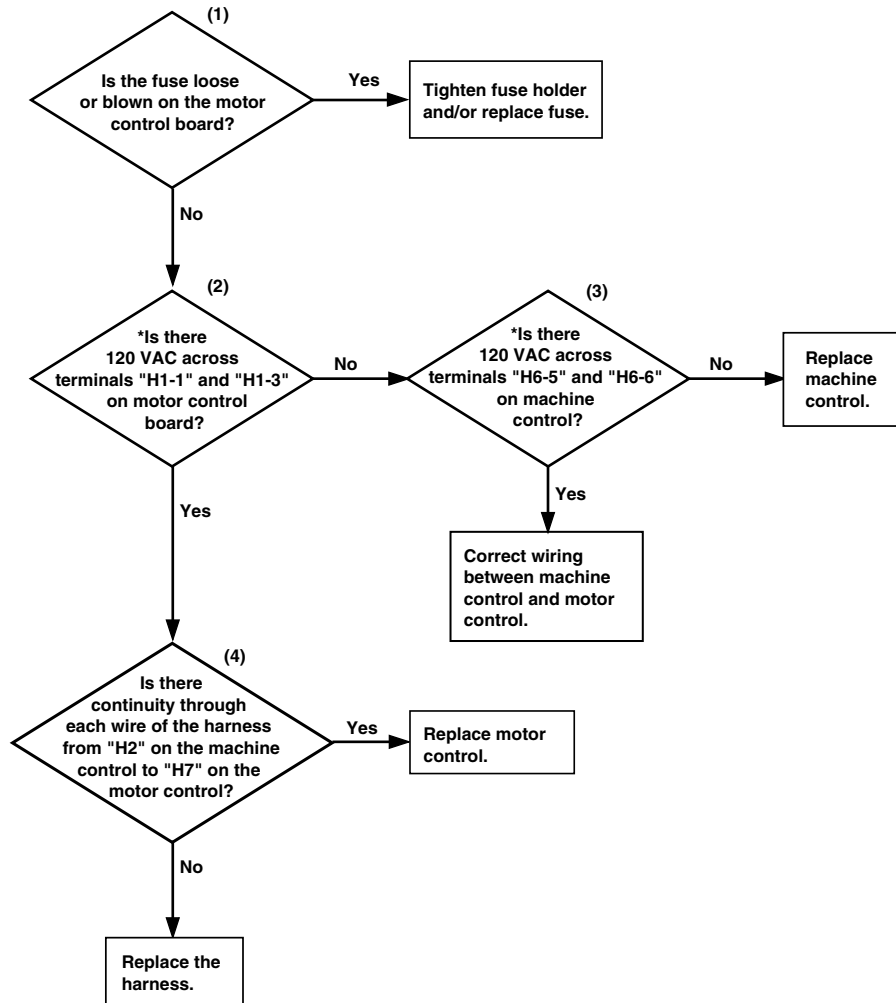

FLW1714S

***NOTE: Machine must be restarted to check voltage. Voltage is intermittently present for the first 15 seconds, until error mode is displayed.**

Serial Communication Error (Final Spin and Tumble/Close Door LEDs Flashing)

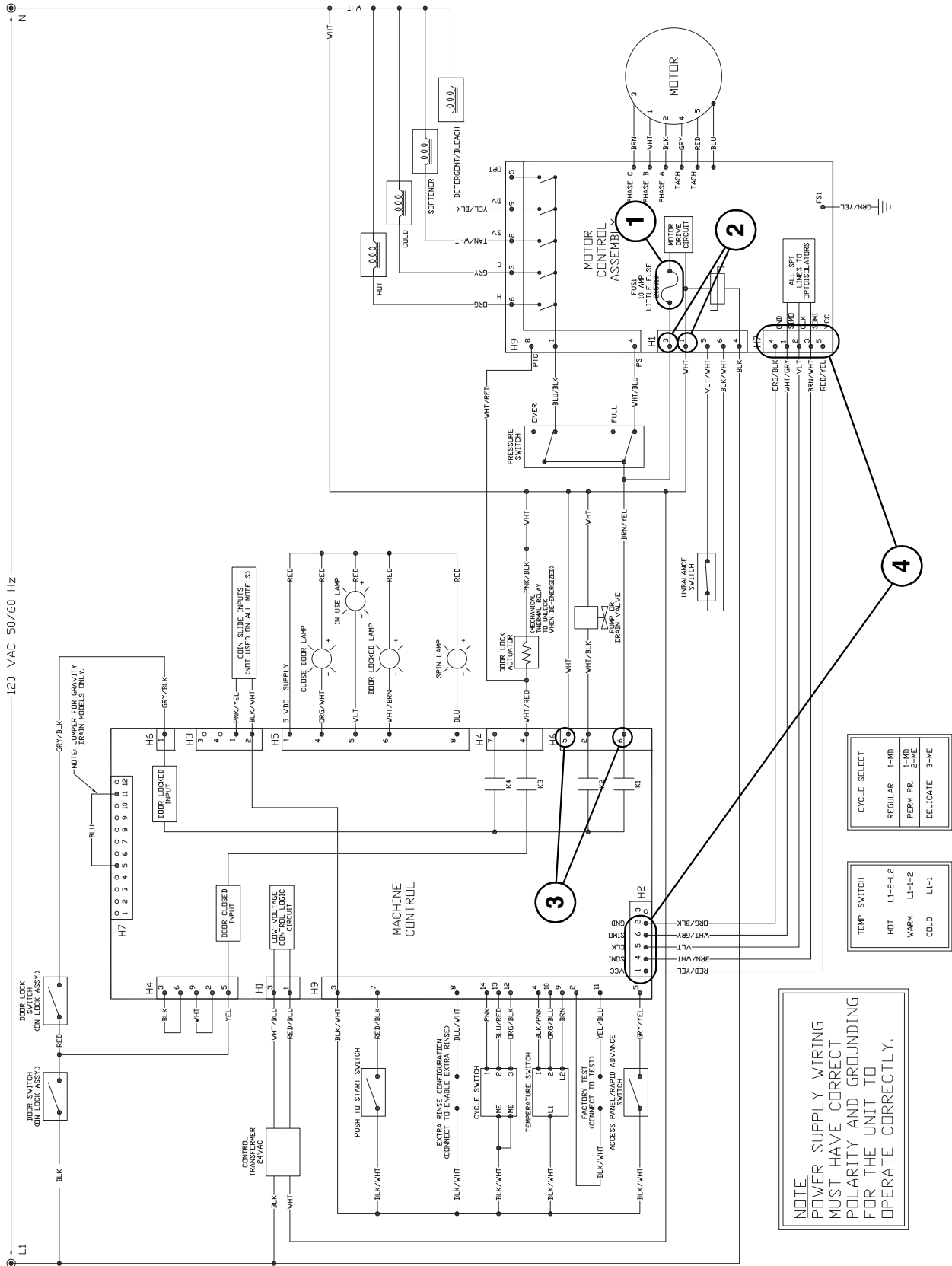

Section 5

NetMaster and MDC Troubleshooting

	WARNING
<p>To reduce the risk of electric shock, fire, explosion, serious injury or death:</p> <ul style="list-style-type: none"> • Disconnect electric power to the washer before servicing. • Never start the washer with any guards/panels removed. • Whenever ground wires are removed during servicing, these ground wires must be reconnected to ensure that the washer is properly grounded. • Motor not grounded! Disconnect electric power before servicing motor. 	
<small>W485</small>	

21. Error Code Listing

E:df	Drive failure.	This error code is generated by the motor control and transmitted to the master control. Several conditions can cause this code; motor unplugged, motor failure, tachometer circuit open, inner basket locked up. This is a fatal error. Machine must be unpowered to reset.
E:SP	Serial communication error.	This error code occurs when the master control cannot communicate with the motor control. The master control will try to reset the motor control by powering it down. It will try resetting three times before setting the error code. Common causes: fuse blown on motor control board, wiring to motor control incorrect. This is a fatal error.
E:FL	Fill error.	This error code occurs if the pressure switch fails to open in 30 minutes in any fill/agitate cycle. This is a fatal error.
door	Door open indicator.	This error code occurs when the door is not closed at the start of an active cycle. If the door is closed, check for wiring or door switches.
E:do	Door open error.	This error code occurs if the control detects the door open and door locked inputs high at the same time. You can get this error if you jerk on the door when it is locked or as it is about to lock. This is a fatal error.
E:dL	Door lock error.	This error code occurs if the door does not lock in 15 seconds or unlock in 3 minutes at the end of the cycle. This is a non-fatal error. If the door locks or unlocks while E:dL is displayed it will clear the error condition. Also if the door is opened after failing to lock it will clear the display.
E:Ht (models equipped with heater)	Heater error.	This error code occurs if it takes more than two hours to heat water to the programmed temperature. The cycle will continue. The code will clear when control exits End of Cycle mode.

(continued)

OP (models equipped with heater)	Open thermistor error.	This error code occurs if the thermistor circuit opens while heating.
SH (models equipped with heater)	Shorted thermistor error.	This error code occurs if the thermistor circuit is shorted while heating.

22. Microwand Does Not Communicate With Control – NetMaster Models Only

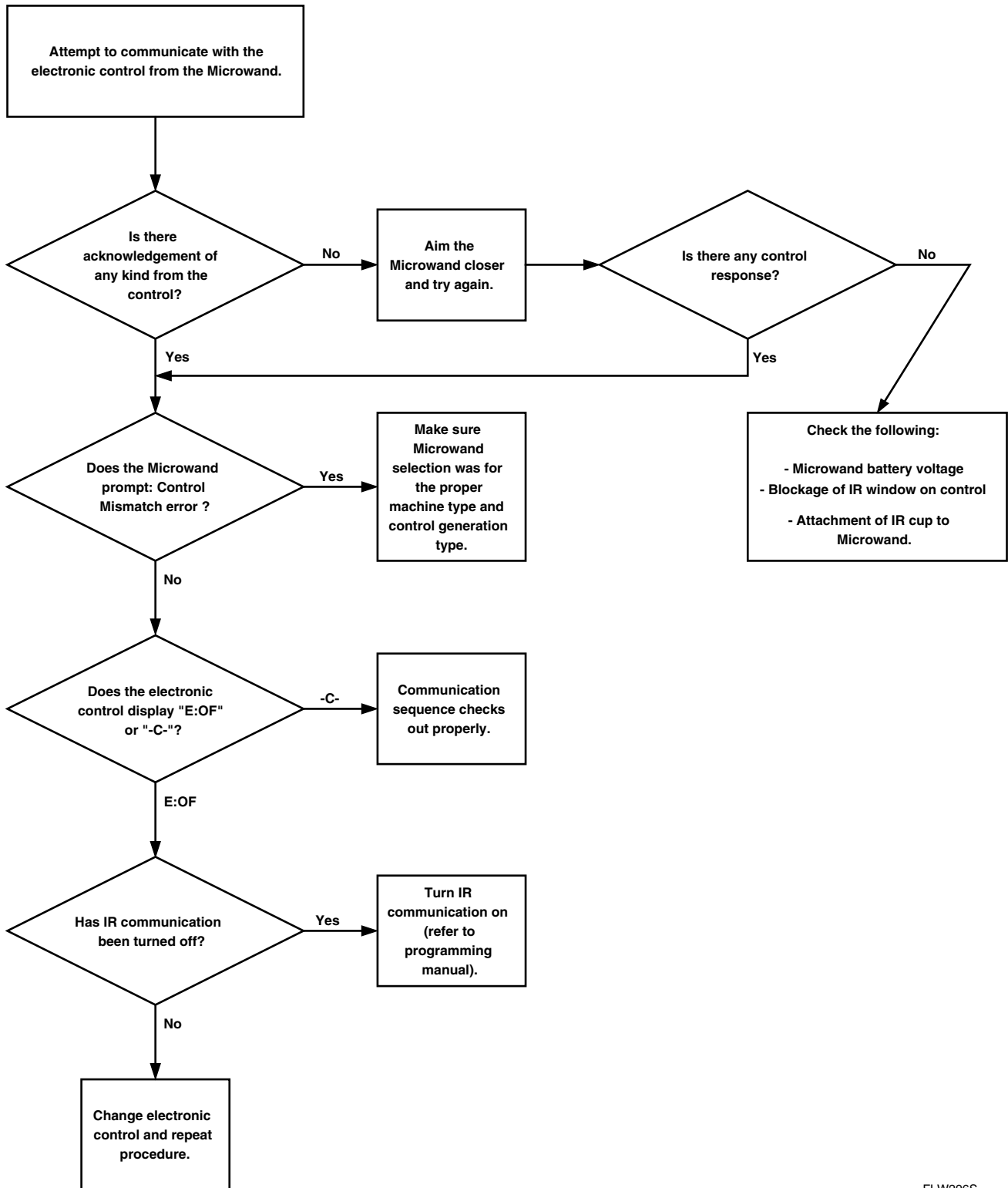

FLW296S

23. Coins Ignored When Entered

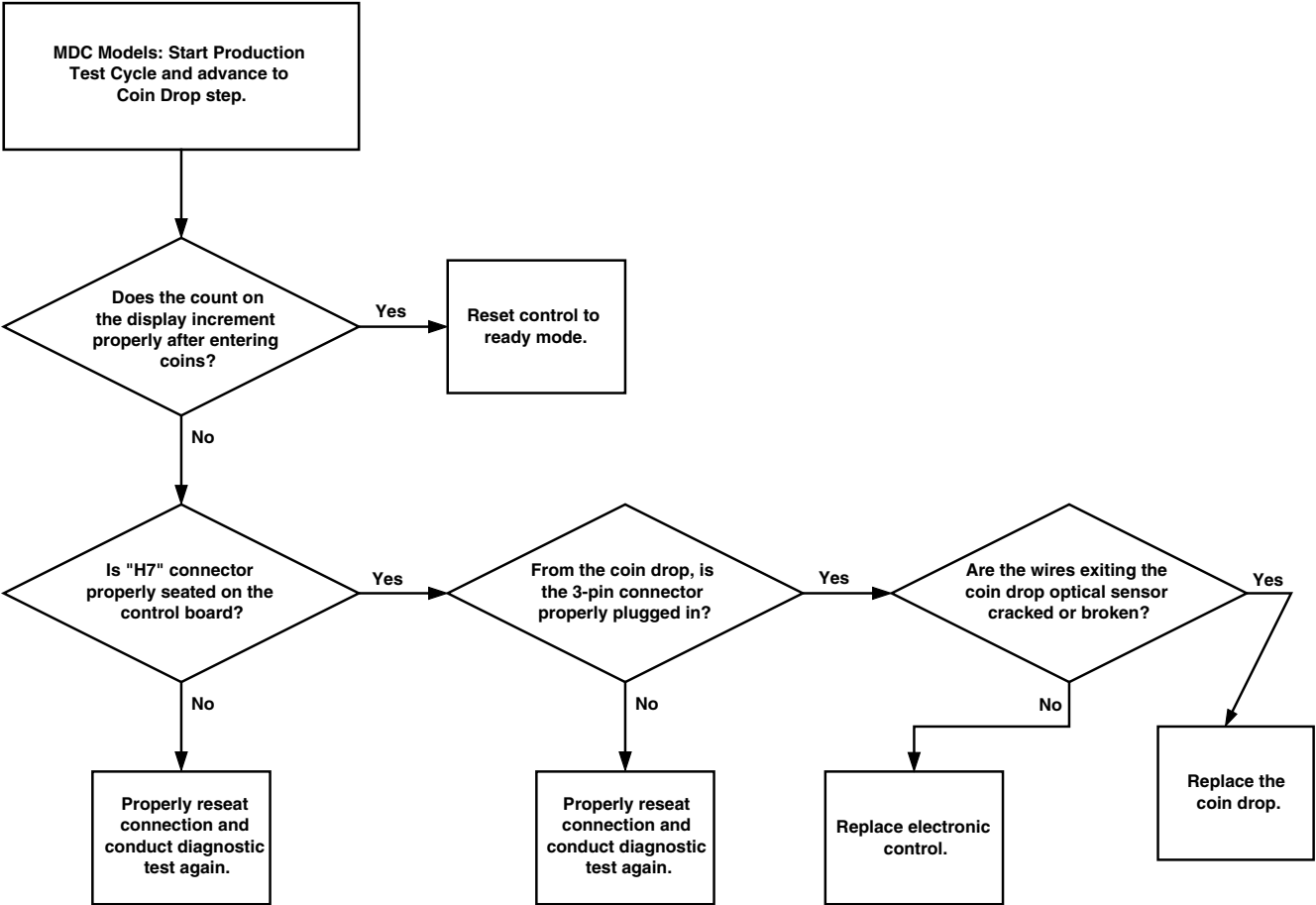

FLW1704S

24. No Visible Display on Control

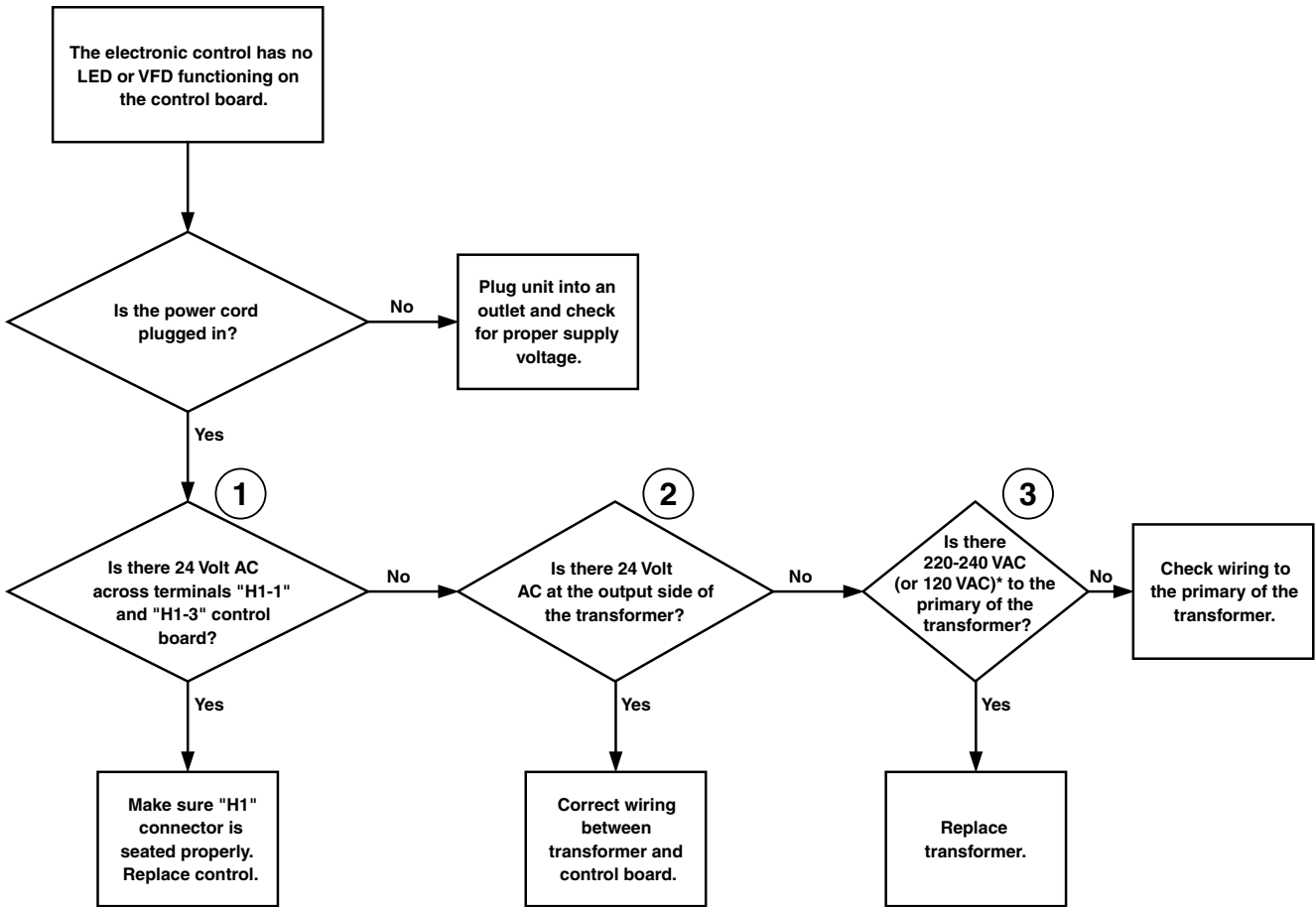

*Refer to machine serial plate for correct voltage.

FLW1695S

No Visible Display on Control

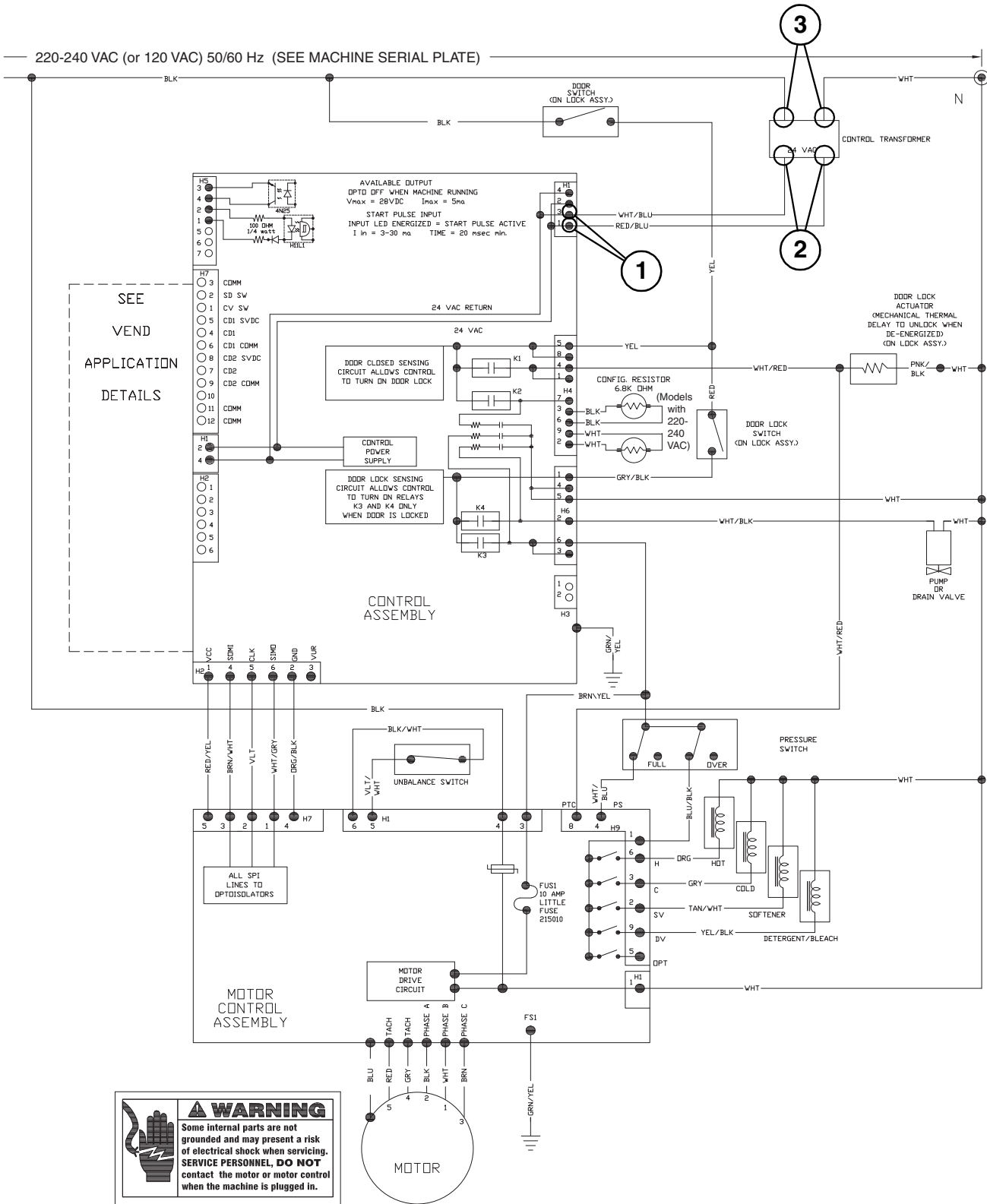

25. Washer Will Not Start – “door” Displayed

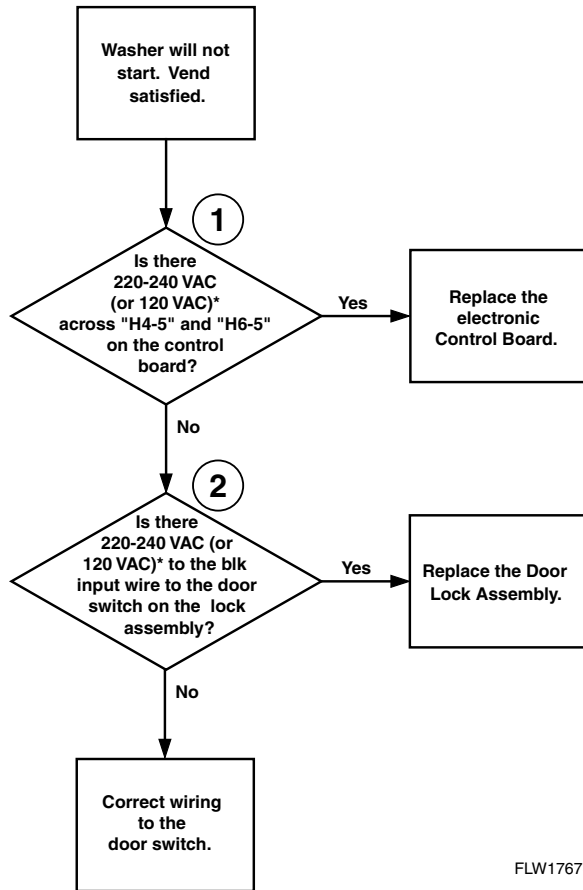

FLW1767S

*Refer to machine serial plate for correct voltage.

Washer Will Not Start – “door” Displayed

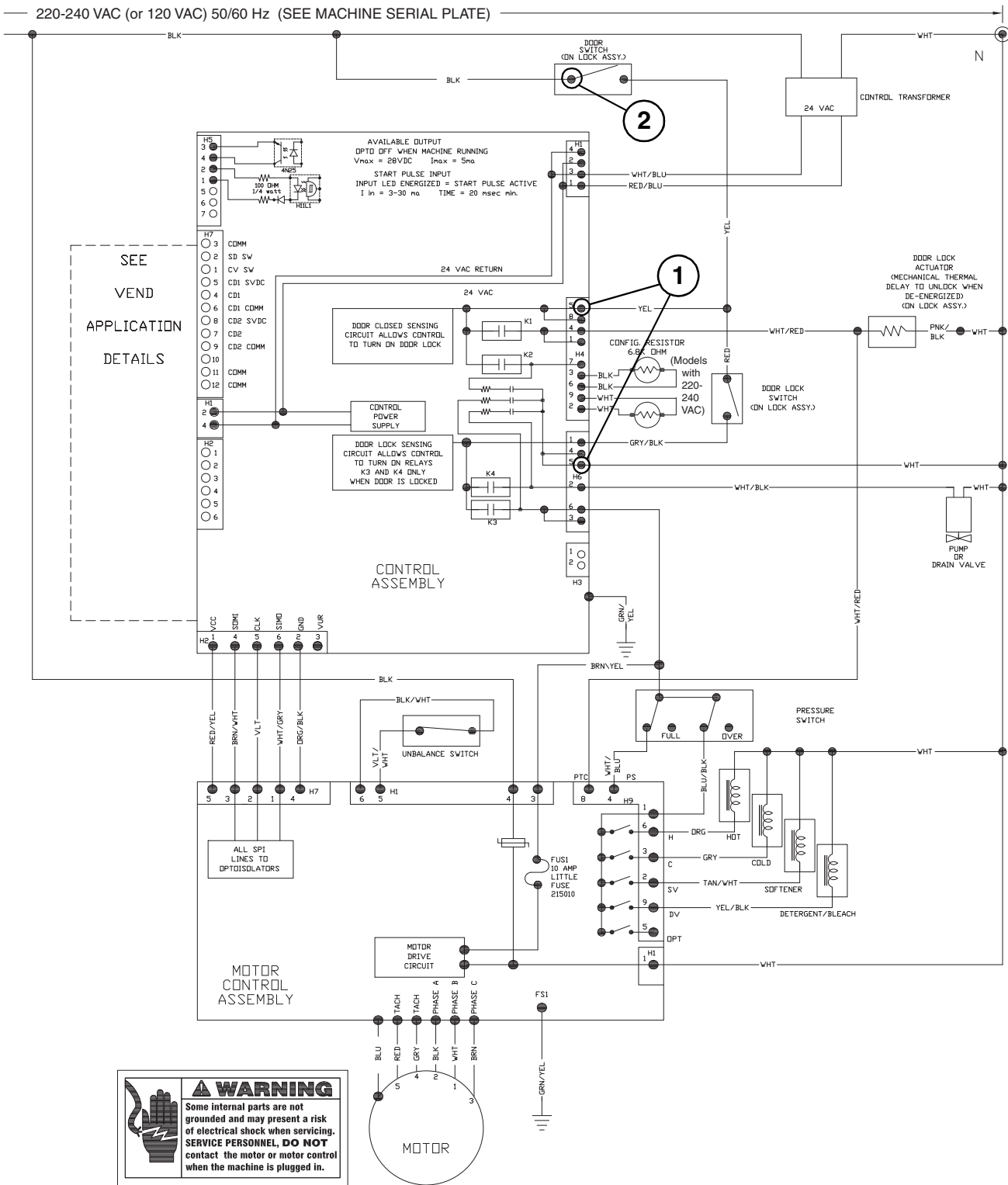

26. Washer Will Not Start – E:dL on Display

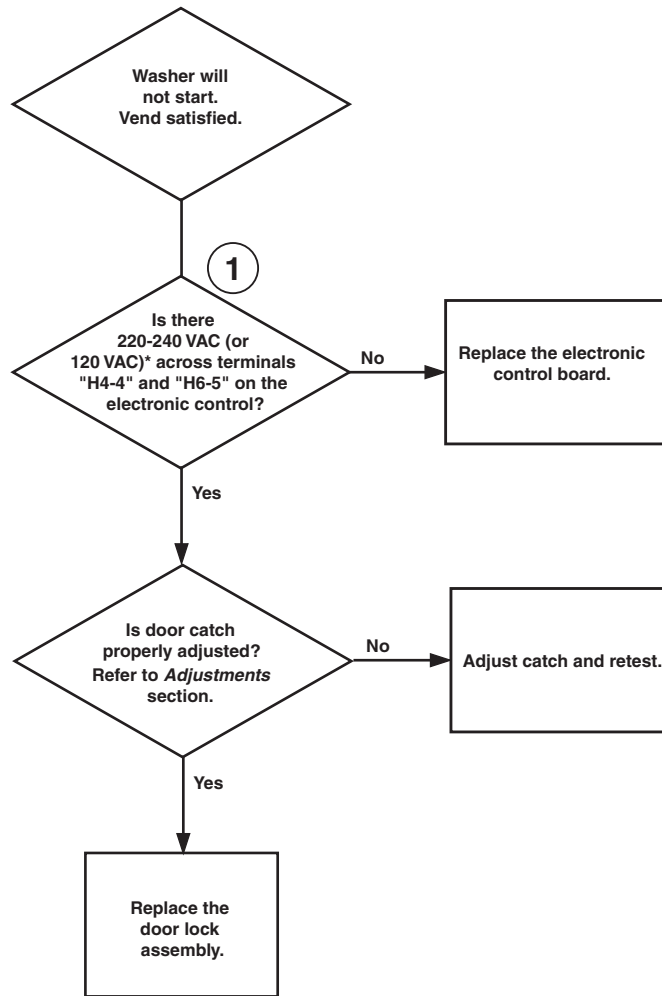

*Refer to machine serial plate for correct voltage.

FLW1773S

Washer Will Not Start – E:dL on Display

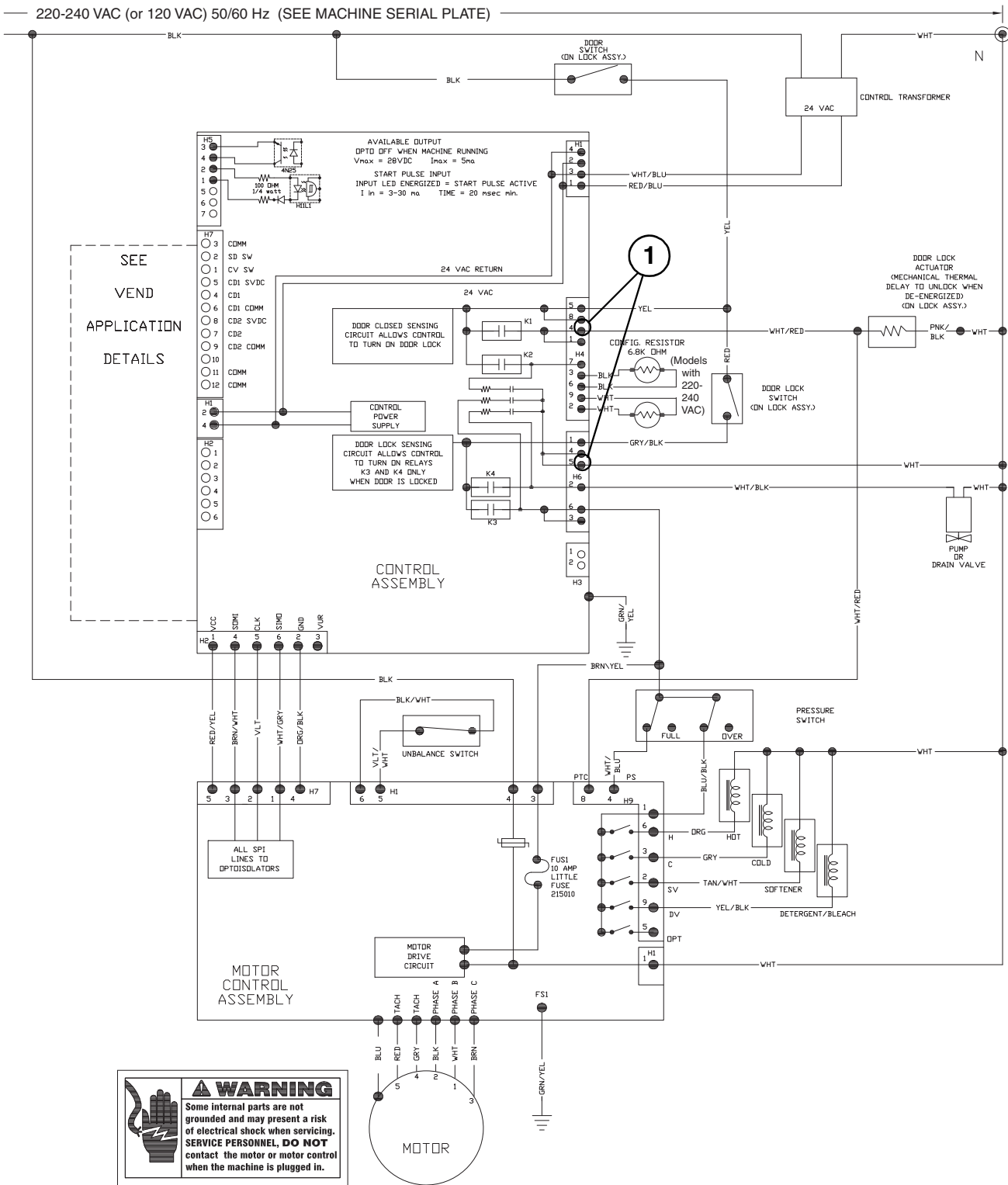

27. Washer Will Not Fill (Machine Empty, No E:SP on Display)

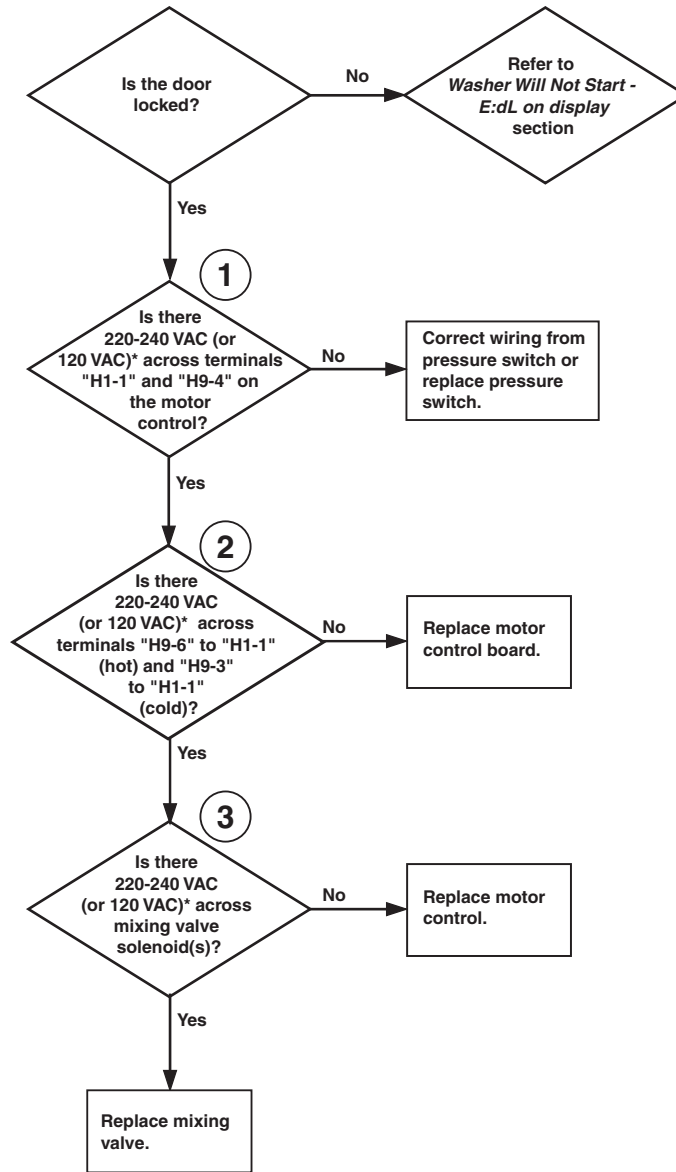

*Refer to machine serial plate for correct voltage.

FLW1698S

Washer Will Not Fill (Machine empty, No E:SP on Display)

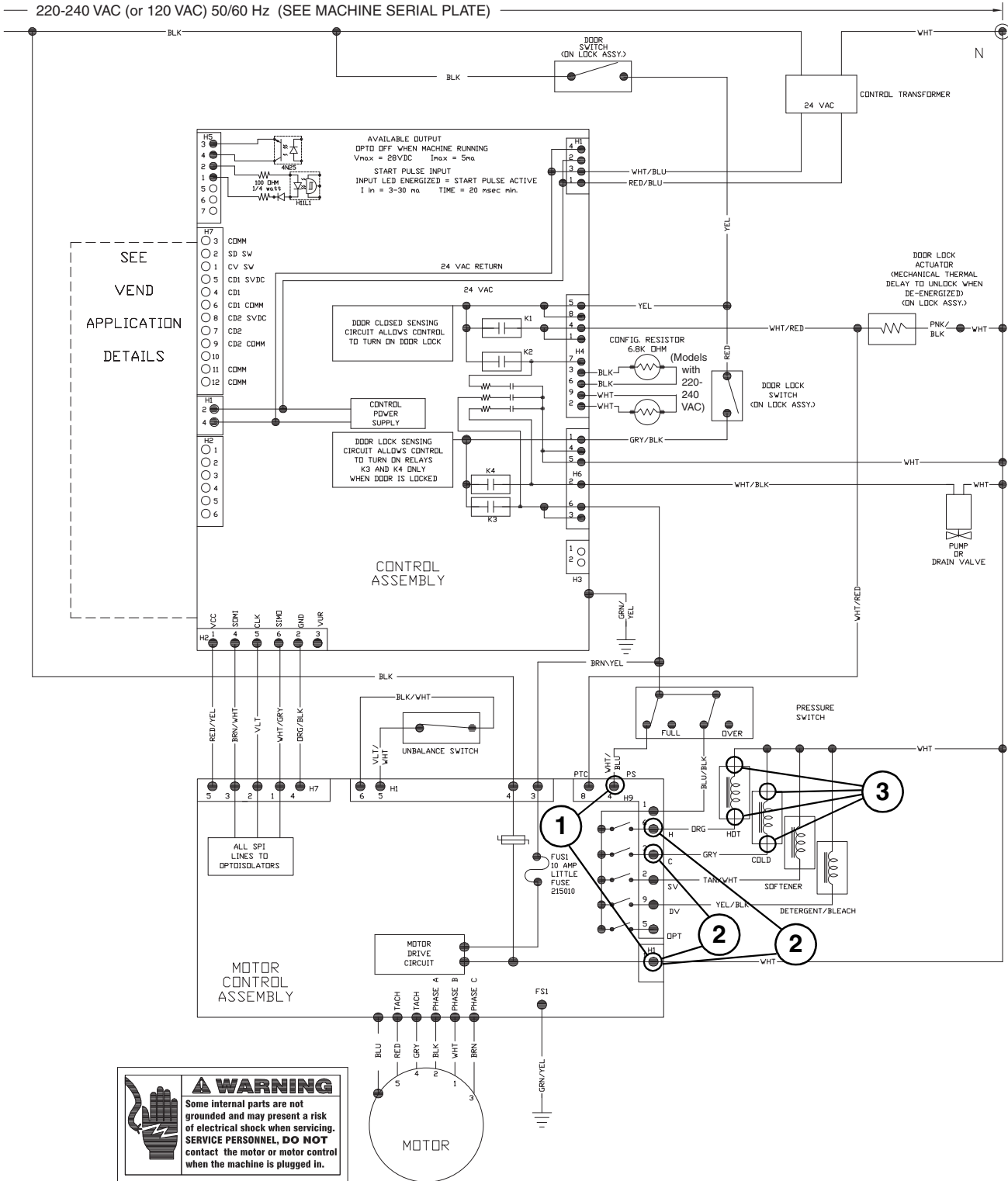

28. Washer Overflows

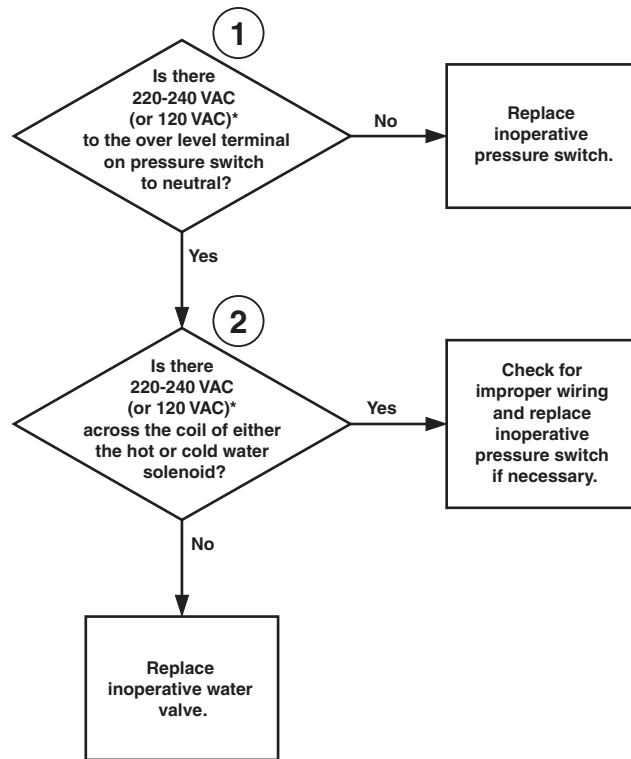

*Refer to machine serial plate for correct voltage.

FLW1699S

29. Pump or Drain Valve Does Not Operate

NOTE: Check at beginning of spin/drain portion of cycle.

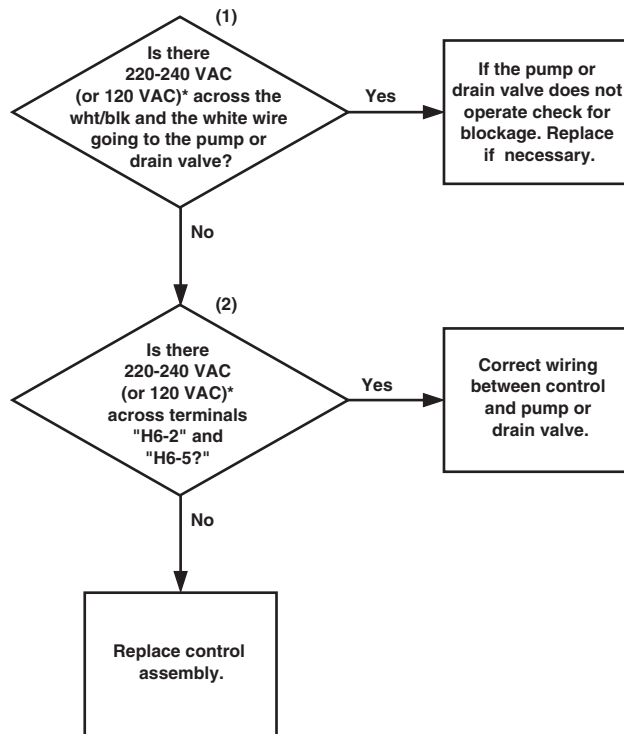

*Refer to machine serial plate for correct voltage.

FLW1700S

30. Serial Communication Error (E:SP on Display)

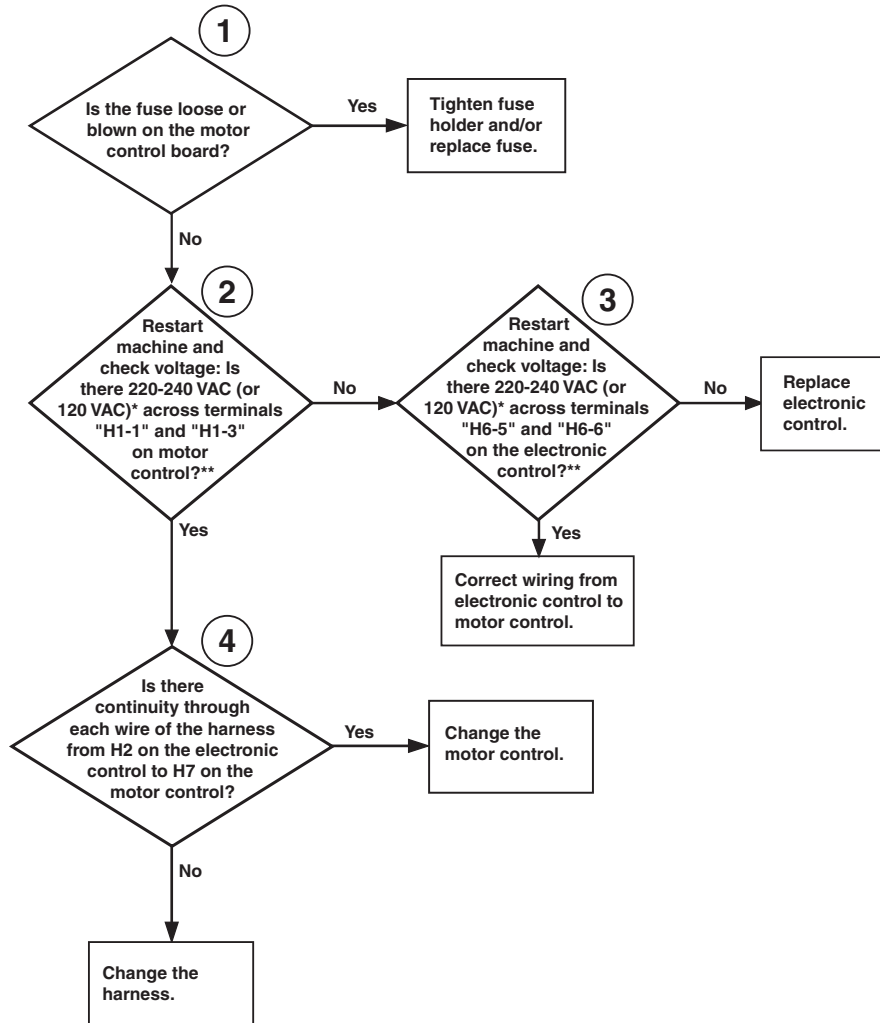

*Refer to machine serial plate for correct voltage.

**NOTE: Machine must be restarted to check voltage. Voltage will be intermittently present during first 15 seconds until E:SP is displayed.

FLW1701S

31. Motor Does Not Run (E:df on Display)

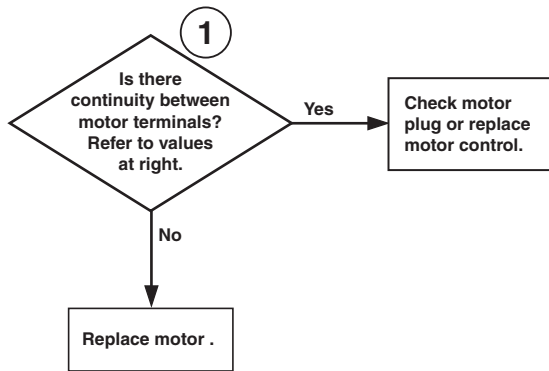

Motor Resistance Values:
Tach. Circuit: Approx. 115 ohms (Terminals 4-5)
Windings: Approx. 4 - 5 ohms (Terminals 1-2, 1-3, 2-3)

FLW1702S

Motor Does Not Run (E:df on Display)

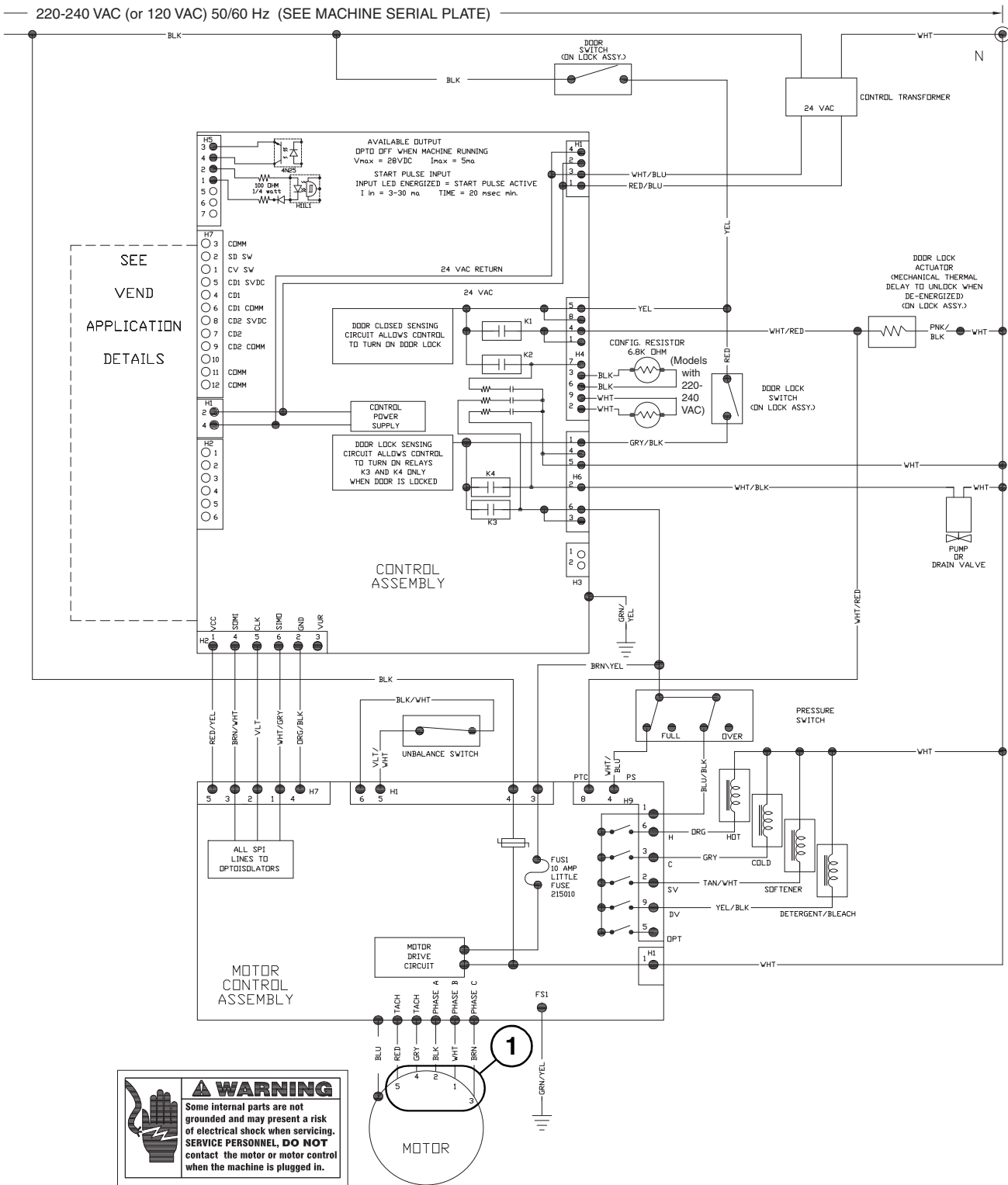

32. Washer Will Not Heat (“OP” or “SH” Displayed)

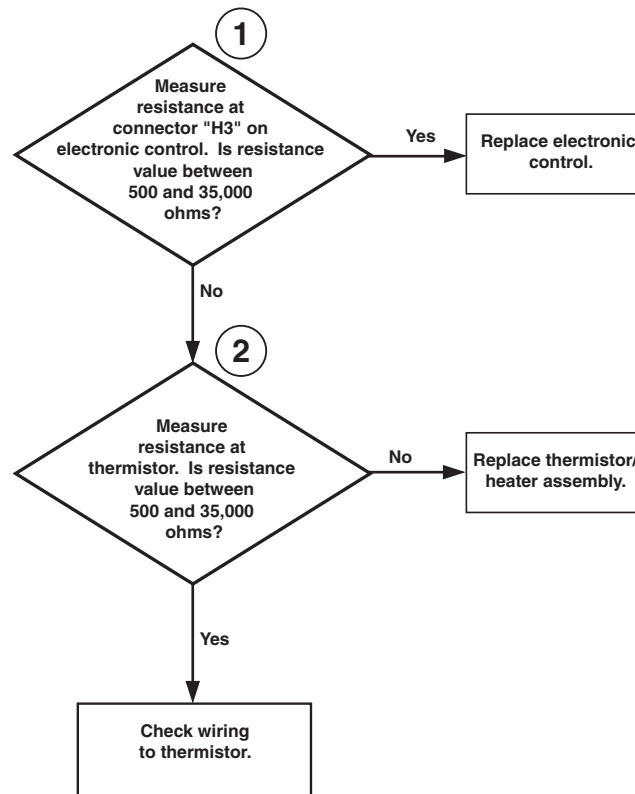

FLW1705S

Washer Will Not Heat ("OP" or "SH" Displayed)

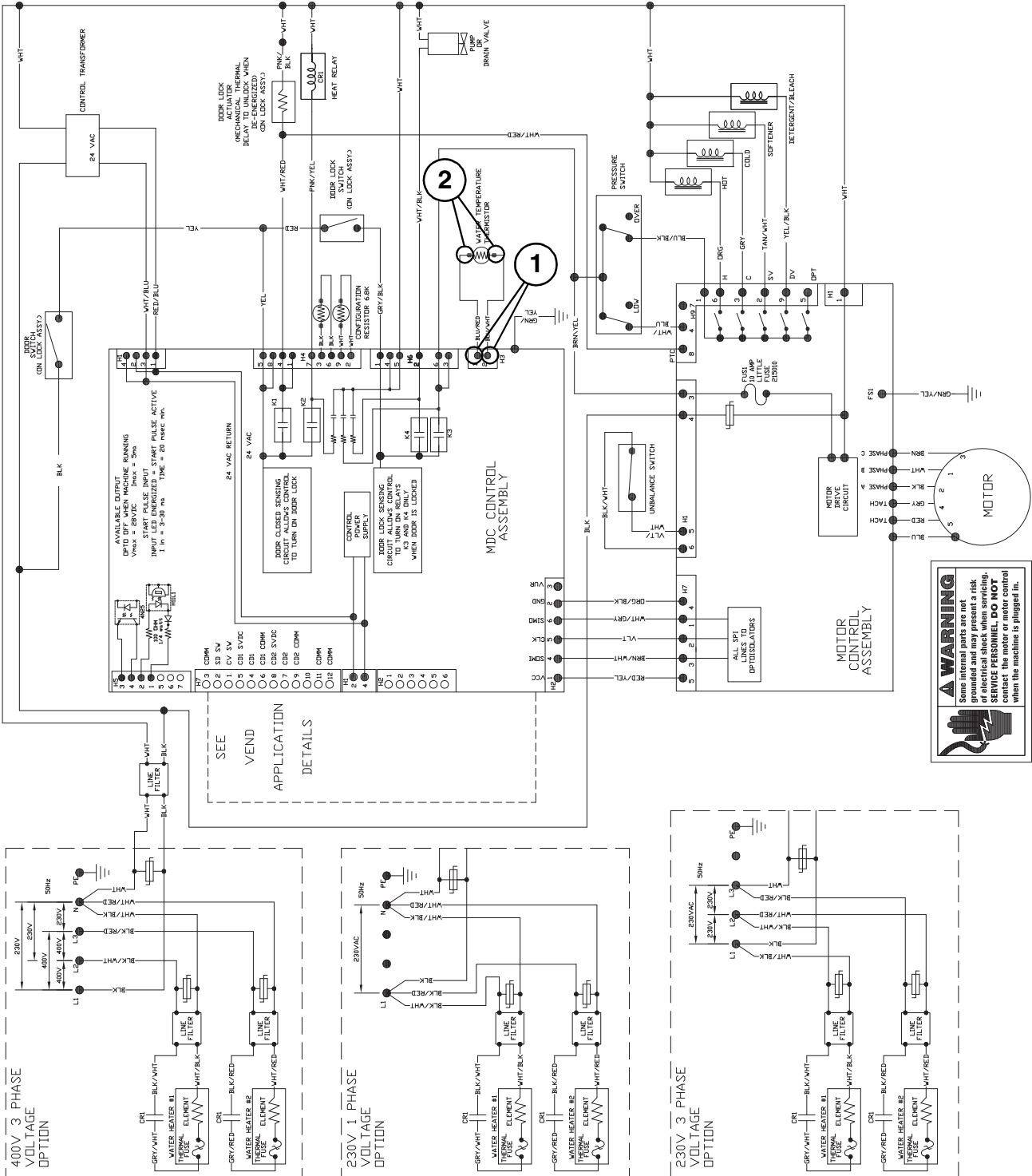

33. Washer Will Not Heat (Models Equipped with Heater) (3 Phase Heater Machines Only)

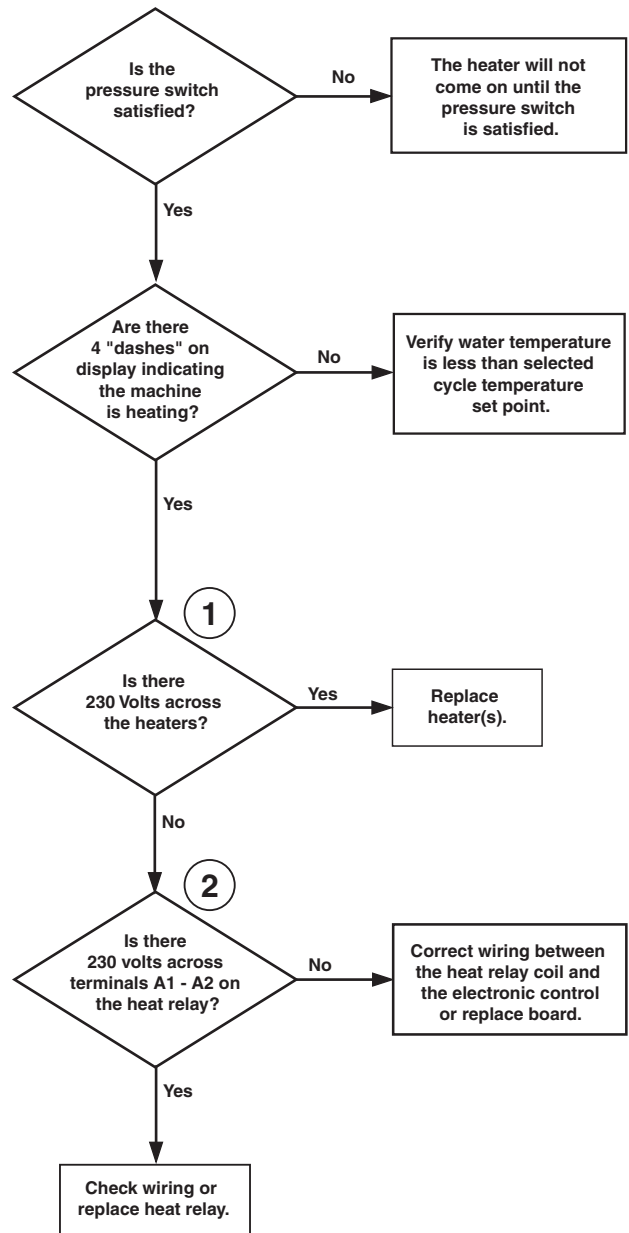

FLW1703S

Washer Will Not Heat (Models Equipped with Heater) (3 Phase Heater Machines Only)

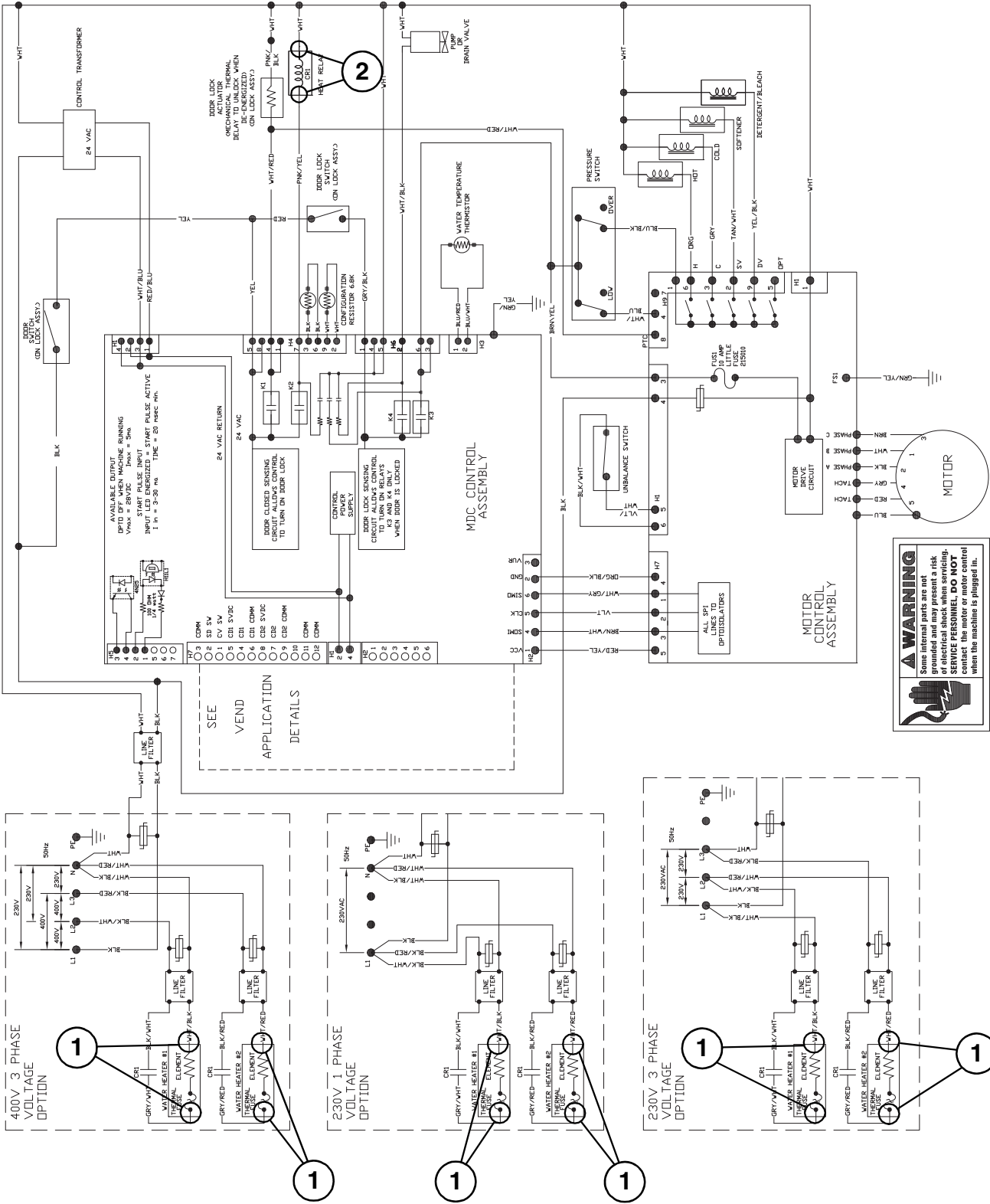

Section 6 Adjustments



WARNING

To reduce the risk of electric shock, fire, explosion, serious injury or death:

- Disconnect electric power to the washer before servicing.
- Never start the washer with any guards/panels removed.
- Whenever ground wires are removed during servicing, these ground wires must be reconnected to ensure that the washer is properly grounded.
- Motor not grounded! Disconnect electric power before servicing motor.

W485

IMPORTANT: When reference is made to directions (right or left) in this manual, it is from operator's position facing front of washer.

34. Cabinet Leveling Legs

- Place washer in position on a solid, sturdy and level floor. Installing the washer on any type of carpeting, soft tile, a platform, or other weak support structures is not recommended.
- Place level on washer, refer to *Figure 12*, and check if washer is level from side to side and front to back.

NOTE: Level must rest on raised portion of top panel. Refer to *Figure 12*.

- If washer is not level, tilt washer to access front and rear leveling legs. For easier access to leveling legs, prop up washer with wooden block. Refer to *Figure 12*.
- Loosen locknuts and adjust the leveling legs until the washer is level from side to side and front to back (using a level). **Make sure washer does not rock.** Refer to *Figure 12*.

- Tighten the locknuts securely against the washer base. If the locknuts are not tight, washer will move out of position during operation.



CAUTION

DO NOT slide washer across floor if the leveling legs have been extended, as legs and base could become damaged.

W248



CAUTION

Use of the dispenser drawer or washer door as a handle in the transportation of the washer may cause damage to the dispenser or door.

W185

- Place rubber feet on all four leveling legs. Refer to *Figure 12*.
- Verify that washer doesn't rock.

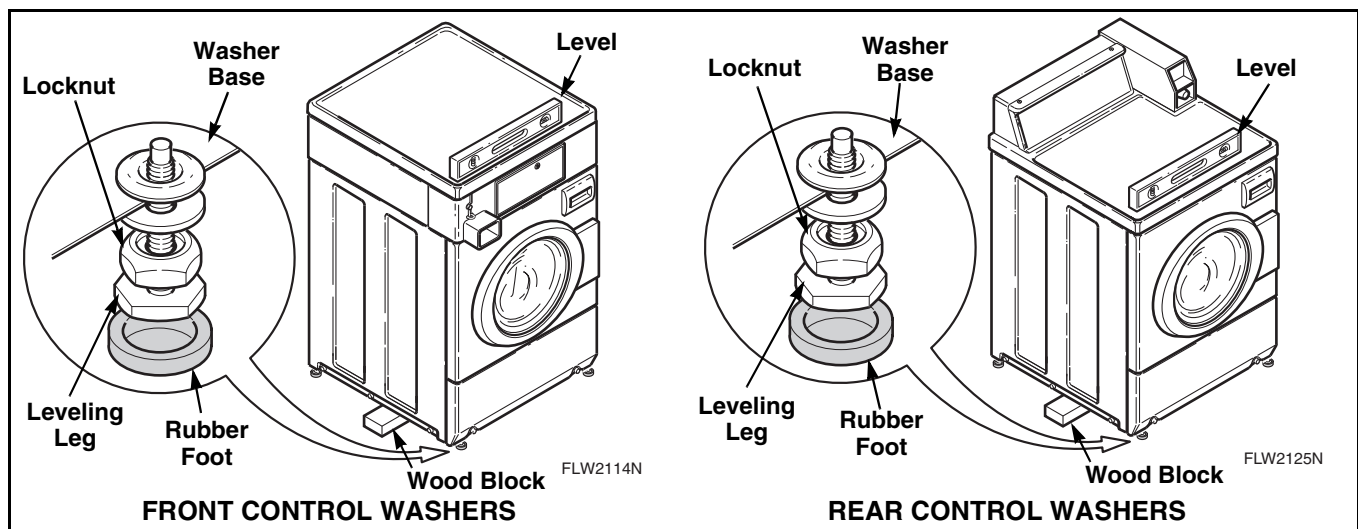

Figure 12



WARNING

To reduce the risk of electric shock, fire, explosion, serious injury or death:

- Disconnect electric power to the washer before servicing.
- Never start the washer with any guards/panels removed.
- Whenever ground wires are removed during servicing, these ground wires must be reconnected to ensure that the washer is properly grounded.
- Motor not grounded! Disconnect electric power before servicing motor.

W485

- h. If unit vibrates or shakes during operation, follow additional leveling procedure below. It is especially effective if unit is installed on uneven, non-concrete surface.
- i. Loosen one front leveling leg locknut. Refer to *Figure 12*.
- j. Run cycle with unbalanced load (single pair of blue jeans or knotted towels).
- k. During 1000 RPM spin, adjust leg up or down by turning it 1/8 turn until washer's vibration is reduced and washer is at its most stable point.
- l. Re-tighten locknut.

35. Loading Door

- a. Open loading door.
- b. The loading door can be adjusted up or down somewhat by loosening screws holding door hinge to front panel, then raise or lower door before retightening screws. Refer to *Figure 13*.

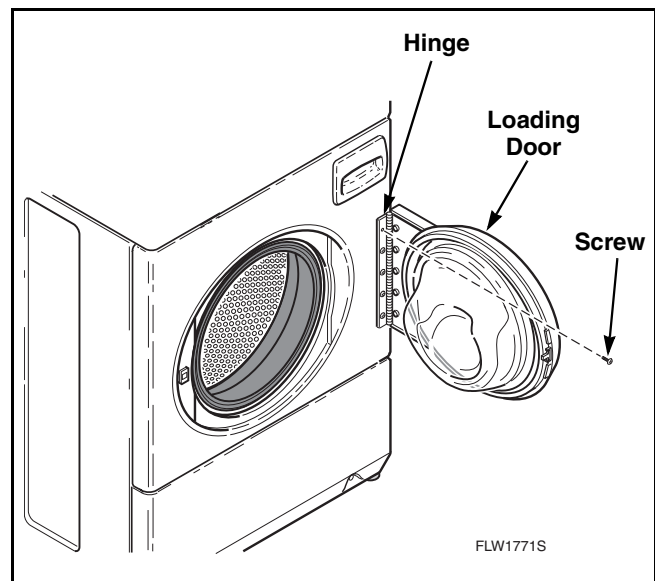

Figure 13



WARNING

To reduce the risk of electric shock, fire, explosion, serious injury or death:

- Disconnect electric power to the washer before servicing.
- Never start the washer with any guards/panels removed.
- Whenever ground wires are removed during servicing, these ground wires must be reconnected to ensure that the washer is properly grounded.
- Motor not grounded! Disconnect electric power before servicing motor.

W485

36. Motor Belt Tension

NOTE: Belt adjustment procedures are done through front of washer, however, as an option, washer can be moved from its location and belt adjustment can be done through lower access panel opening at rear of washer.

- While supporting lower front access panel, remove two screws from bottom edge of access panel and remove panel.
- Working through the lower front access door opening, place a locking pliers on the metal rod and loosen the two adjusting bolts. Refer

to *Figure 14*. Repeat procedure to loosen the two pivot bolts. Refer to *Figure 14*.

- Pull down on motor to increase belt tension. Use a Burroughs belt gauge to obtain proper tension. Proper belt tension is obtained when belt can be deflected approximately 1/4 inch (6.35 mm) from normal position when moderate pressure 50 to 60 pounds (22.68 to 27.22 Kg) is applied to a point midway between pulleys. Refer to *Figure 14*.
- After proper belt tension has been obtained, tighten belt adjusting bolts firmly, then tighten pivot bolts. Refer to *Figure 14*.

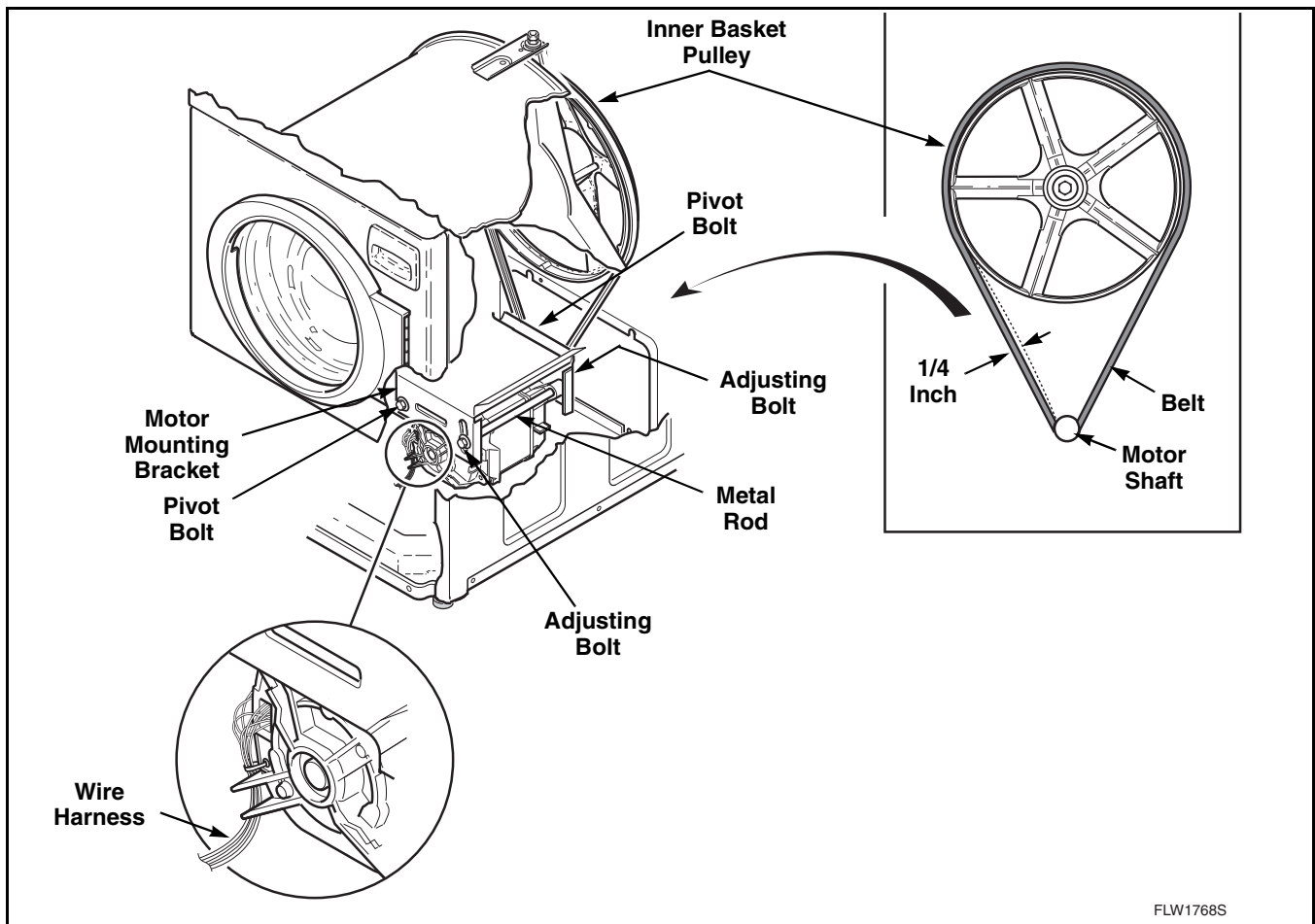

FLW1768S

Figure 14



WARNING

To reduce the risk of electric shock, fire, explosion, serious injury or death:

- Disconnect electric power to the washer before servicing.
- Never start the washer with any guards/panels removed.
- Whenever ground wires are removed during servicing, these ground wires must be reconnected to ensure that the washer is properly grounded.
- Motor not grounded! Disconnect electric power before servicing motor.

W485

37. Door Catch

NOTE: When repairing a broken or inoperative No. 802803 Door Catch, proceed as follows:

- a. Open loading door.
- b. Remove 11 T-20 Torx head screws holding outer door bezel to inner door bezel. Refer to *Figure 15*.
- c. Pull hinge side of outer bezel away from door and slide forward. Refer to *Figure 15*.
- d. Remove two screws and nuts holding door catch to door and remove door catch.
- e. Install new door catch and tighten screws and nuts to the point of being snug.
- f. Adjust door catch so the outside edge is aligned with the edge of the lock. Refer to *Figure 16*.

- g. Visually check that the door catch properly engages the funnel of the door latch/switch assembly. Refer to *Figure 16*.
- h. Recheck the alignment in Step f. Adjust if needed.
- i. Torque the two nuts to approximately 20 inch pounds (2.25 Nm).
- j. Reinstall outer door bezel by aligning outer bezel tabs with cut aways on inner bezel and sliding outer bezel into position. Refer to *Figure 15*.
- k. Replace 11 screws holding outer door bezel to inner door bezel.

IMPORTANT: Do not overtighten screws or bezel holes will strip.

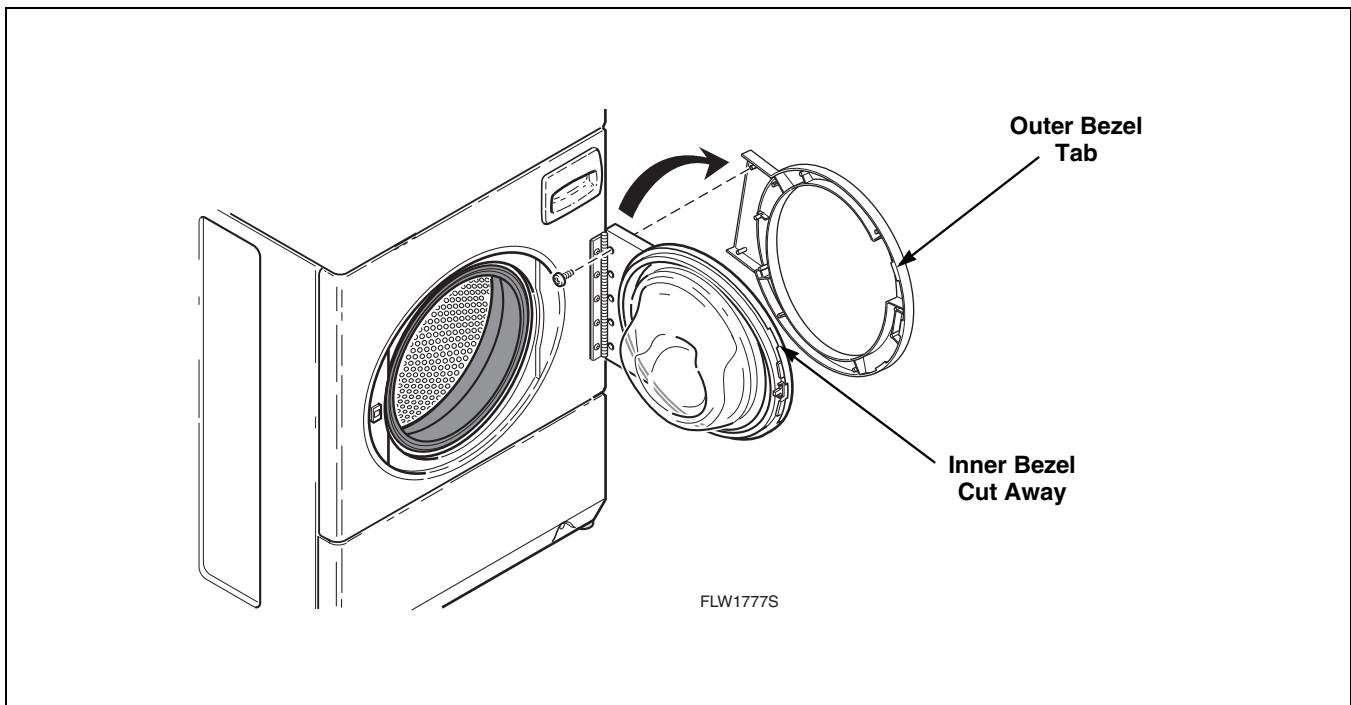

Figure 15



WARNING

To reduce the risk of electric shock, fire, explosion, serious injury or death:

- Disconnect electric power to the washer before servicing.
- Never start the washer with any guards/panels removed.
- Whenever ground wires are removed during servicing, these ground wires must be reconnected to ensure that the washer is properly grounded.
- Motor not grounded! Disconnect electric power before servicing motor.

W485

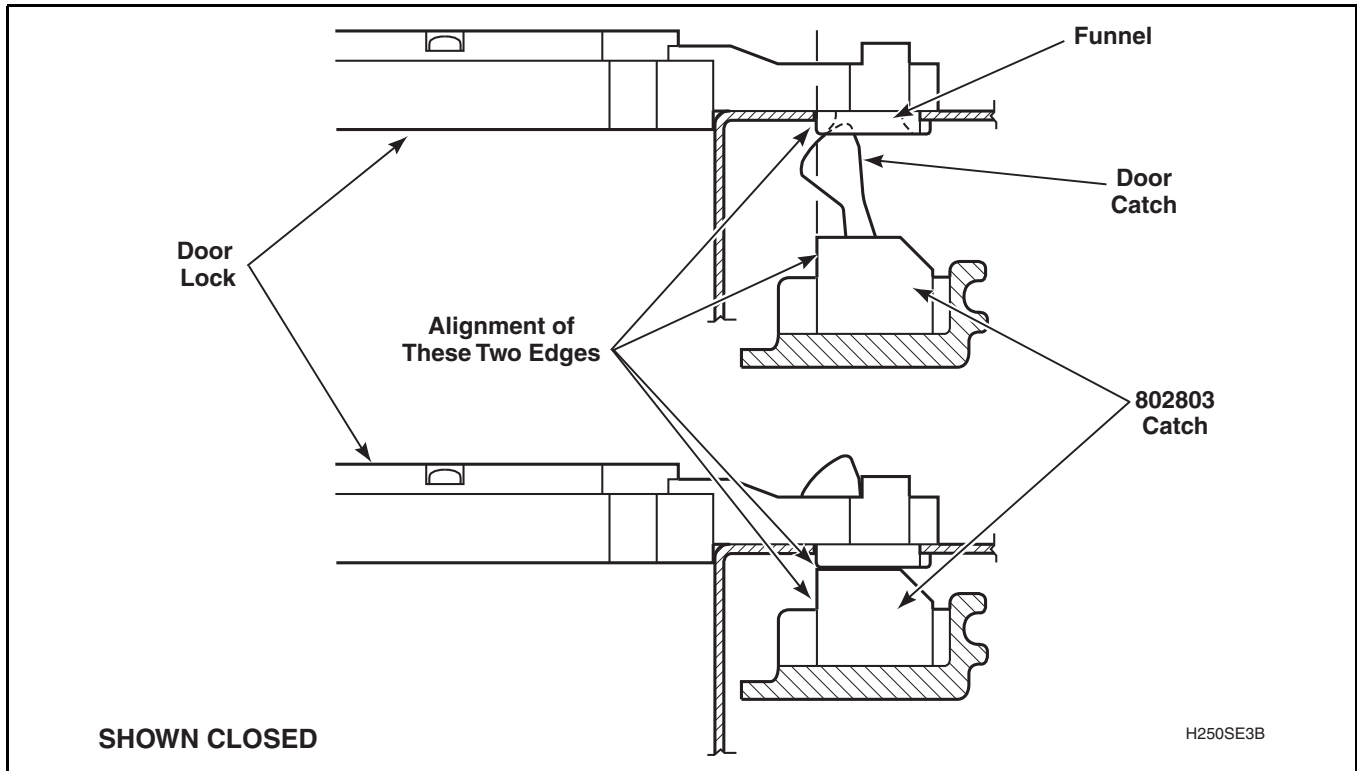

Figure 16



WARNING

To reduce the risk of electric shock, fire, explosion, serious injury or death:

- Disconnect electric power to the washer before servicing.
- Never start the washer with any guards/panels removed.
- Whenever ground wires are removed during servicing, these ground wires must be reconnected to ensure that the washer is properly grounded.
- Motor not grounded! Disconnect electric power before servicing motor.

W485

38. Shipping Braces

All frontload washers, when shipped from the factory are equipped with two factory installed shipping supports. **DO NOT** remove this shipping material until after washer is placed in its final installed position. Refer to *Figure 17*.

damage to the shock absorbers and will **VOID** the product warranty.

NOTE: Shipping supports MUST be kept for future re-positioning or moving of the washer.

IMPORTANT: DO NOT tip or move washer once these supports have been removed. Removal of supports prior to final installation may cause

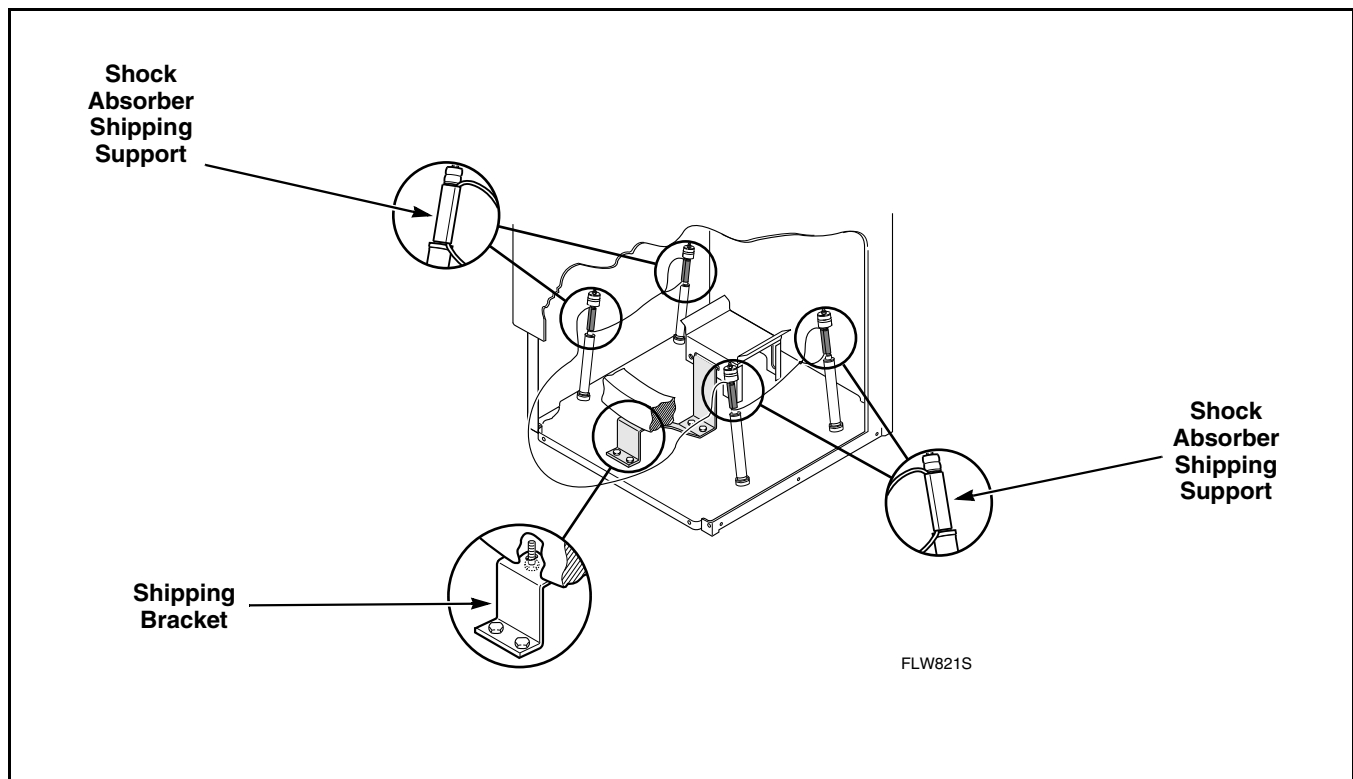

Figure 17



WARNING

To reduce the risk of electric shock, fire, explosion, serious injury or death:

- Disconnect electric power to the washer before servicing.
- Never start the washer with any guards/panels removed.
- Whenever ground wires are removed during servicing, these ground wires must be reconnected to ensure that the washer is properly grounded.
- Motor not grounded! Disconnect electric power before servicing motor.

W485

39. Cleaning Non-Electronic Coin Drop

- a. Disconnect electrical power to machine and drop.
- b. Remove coin drop from machine.
- c. If lint is preventing coins from rolling through coin drop, blow compressed air through coin drop, and along the side of the coin drop. Refer to *Figure 18*.

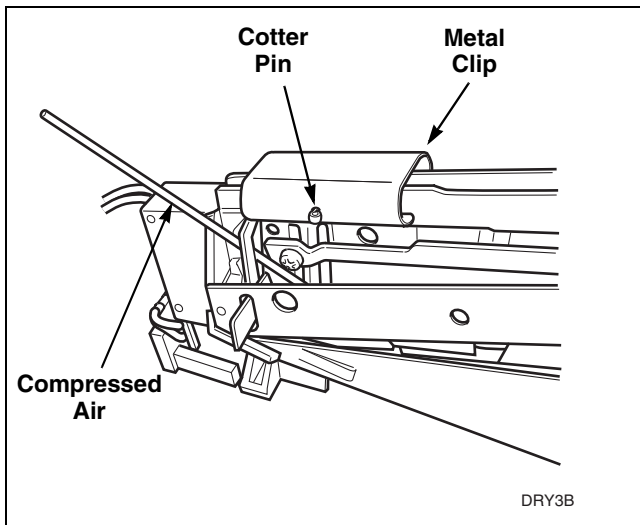

Figure 18

- d. Insert a coin through the coin drop. If coin does not roll through drop, continue with the following.
- e. Remove cotter pin from top of drop. Refer to *Figure 18*. Save pin for reinstallation when cleaning is complete.
- f. Move metal clip closer to sensor so that it comes off frame. Refer to *Figure 18*.

- g. Remove coin return from coin drop frame. Refer to *Figure 19*.

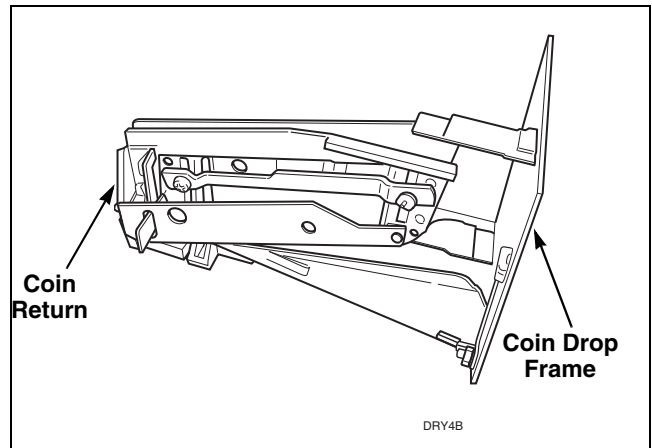

Figure 19

- h. Check coin path in coin drop for lint and residue. If lint or light residues are present, use a cotton swab to remove. If heavy residue is present, it may be necessary to first scrape off excessive residue and then use a cotton swab dipped in water or isopropyl alcohol (rubbing alcohol) to remove remainder of residue. Refer to *Figure 20*.

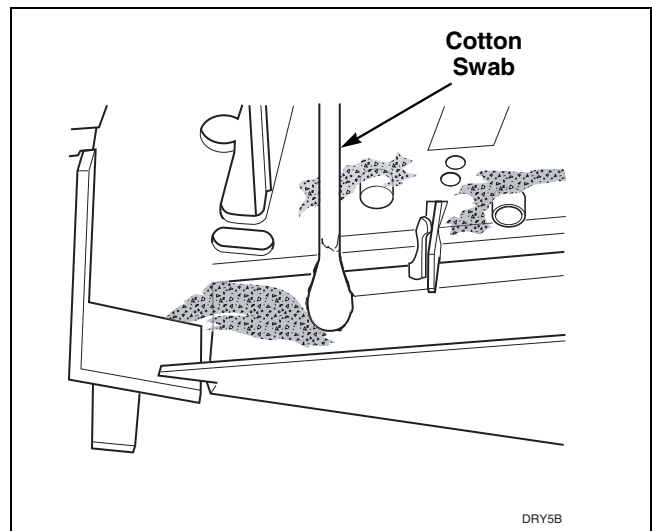

Figure 20



WARNING

To reduce the risk of electric shock, fire, explosion, serious injury or death:

- Disconnect electric power to the washer before servicing.
- Never start the washer with any guards/panels removed.
- Whenever ground wires are removed during servicing, these ground wires must be reconnected to ensure that the washer is properly grounded.
- Motor not grounded! Disconnect electric power before servicing motor.

W485

- i. Check coin return pendulum to verify it swings freely. If pendulum does not swing freely, spray pendulum pivot point with Teflon based lubricant and move pendulum back and forth two to three times. An additional application of Teflon based lubricant may be necessary to ensure that pendulum swings freely. Refer to *Figure 21*.

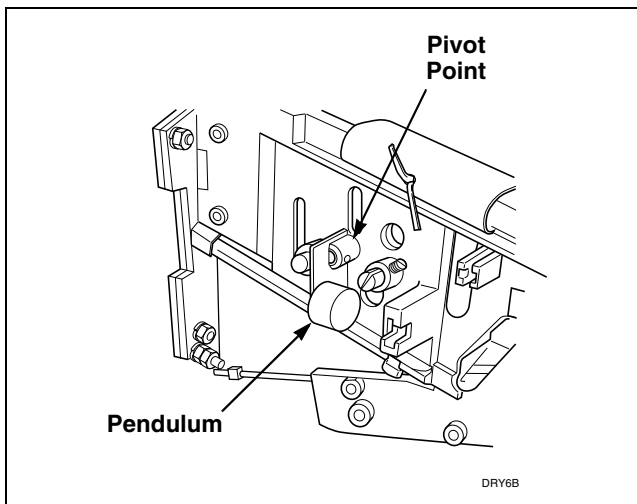

Figure 21

- j. Check coin drop sensor for dust or dirt on eyes. Wipe eyes with dry cotton swab. Refer to *Figure 22*.

IMPORTANT: DO NOT use isopropyl alcohol to clean electronic sensor or eyes.

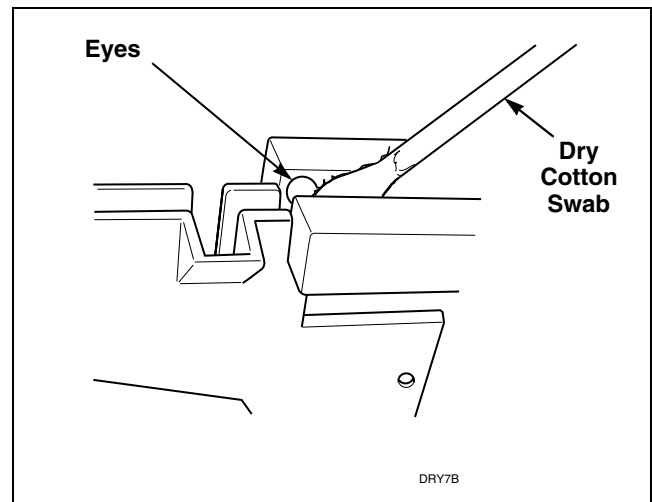

Figure 22

- k. Reinstall coin return on to coin drop frame.
- l. Reinstall metal clip and slide towards coin insert slot. All cotter pin holes must line up.
 - m. Reinstall cotter pin.
 - n. Place drop on level surface to verify that coins follow correct path in drop. It may be necessary to lift drop to allow coin to follow through sensor.
 - o. Reinstall coin drop into machine.
 - p. Reconnect electrical power to machine and drop.
 - q. Add a coin to drop to verify that coin drop is operating properly and that electrical connection is working properly.

NOTE: If coin drop does not operate properly after above steps have been completed, corrosion of metal or vandalized components within coin drop may be preventing the coin drop from functioning correctly. Replace coin drop.



WARNING

To reduce the risk of electric shock, fire, explosion, serious injury or death:

- Disconnect electric power to the washer before servicing.
- Never start the washer with any guards/panels removed.
- Whenever ground wires are removed during servicing, these ground wires must be reconnected to ensure that the washer is properly grounded.
- Motor not grounded! Disconnect electric power before servicing motor.

W485

40. Cleaning Electronic Coin Drop

NOTE: The electronic coin drop should be cleaned once a year. Clean the drop more often if it is exposed to high levels of residue or lint build-up.

- a. Disconnect electrical power to machine and drop.
- b. Remove coin drop from machine.
- c. Check the spring style of coin drop.

Coin Drops with Old-Style Spring (refer to Figure 23):

- (1) Move spring downward until cover catch is free. Refer to *Figure 23*.

NOTE: Do not lift or overbend the spring in any direction.

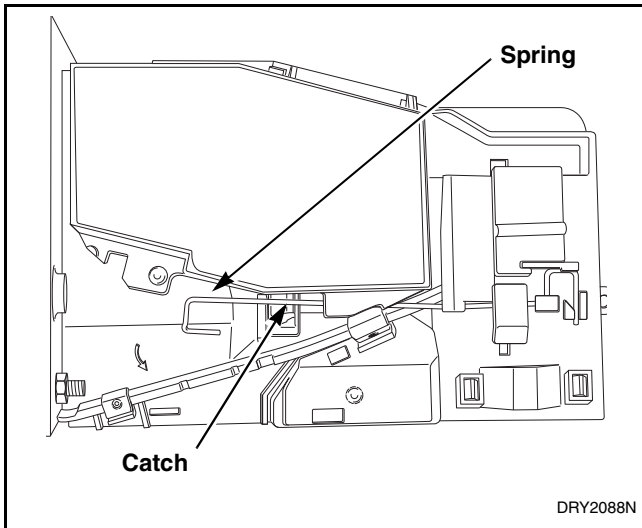

Figure 23

- (2) Open cover for coin drop. Refer to *Figure 24*.

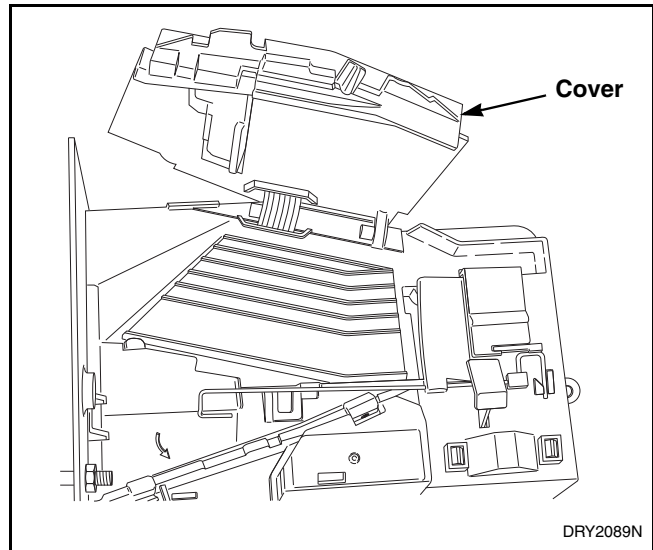

Figure 24

Coin Drops with New-Style Spring (refer to Figure 25):

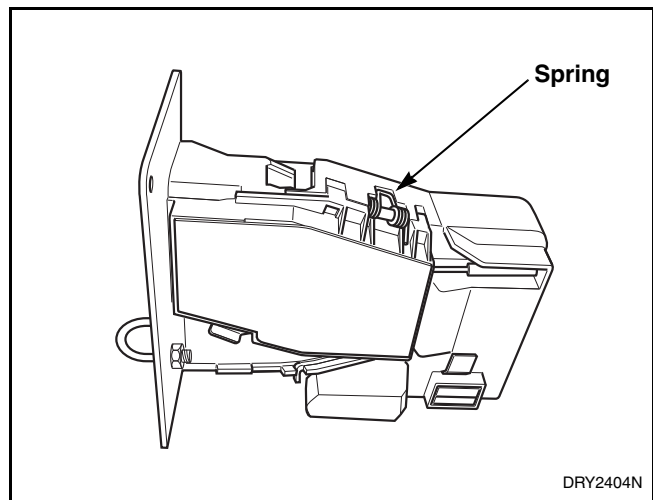

Figure 25

- (3) Open cover of coin drop. Refer to *Figure 26*.



WARNING

To reduce the risk of electric shock, fire, explosion, serious injury or death:

- Disconnect electric power to the washer before servicing.
- Never start the washer with any guards/panels removed.
- Whenever ground wires are removed during servicing, these ground wires must be reconnected to ensure that the washer is properly grounded.
- Motor not grounded! Disconnect electric power before servicing motor.

W485

NOTE: Do not overbend the spring by opening cover too far.

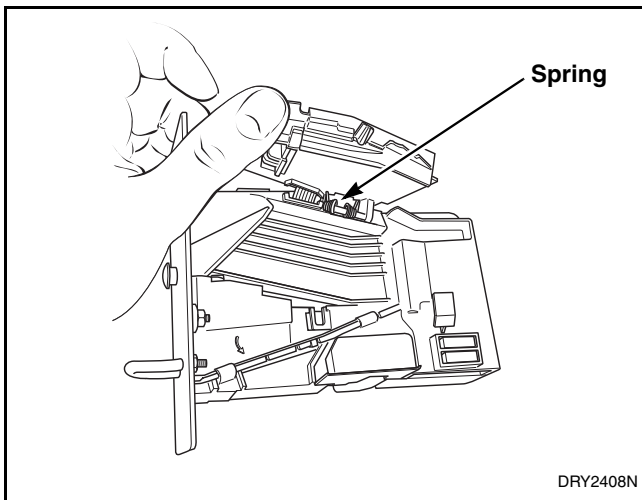

Figure 26

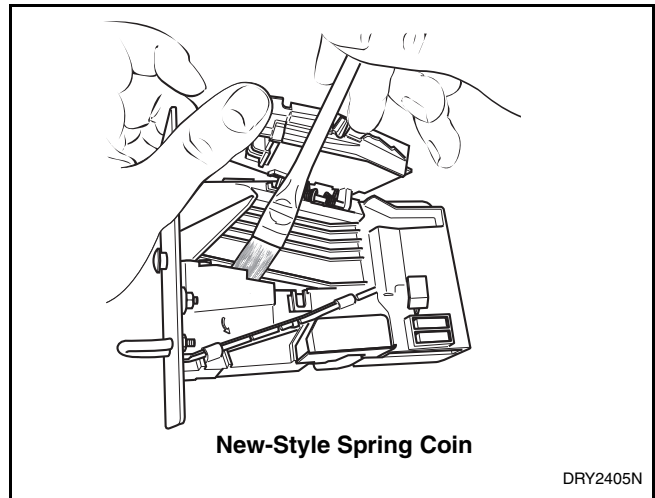

Figure 28

- e. Clean residue from coin rail with an alcohol moistened cloth. Refer to *Figure 29*.

- d. Clean the coin path with a soft brush and wipe exposed surfaces with an alcohol moistened cloth. Refer to *Figure 27* or *Figure 28*.

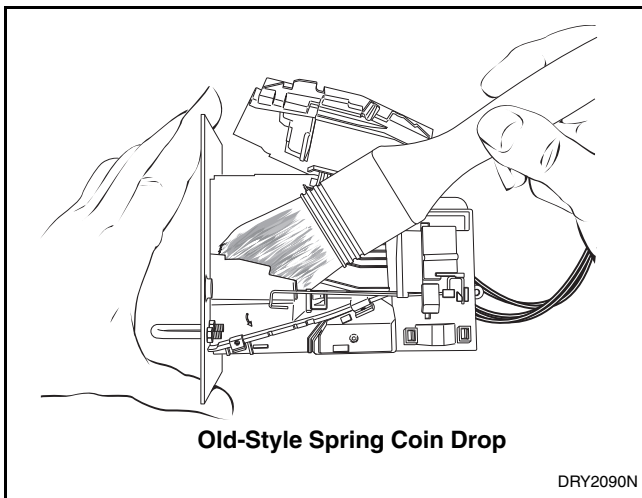

Figure 27

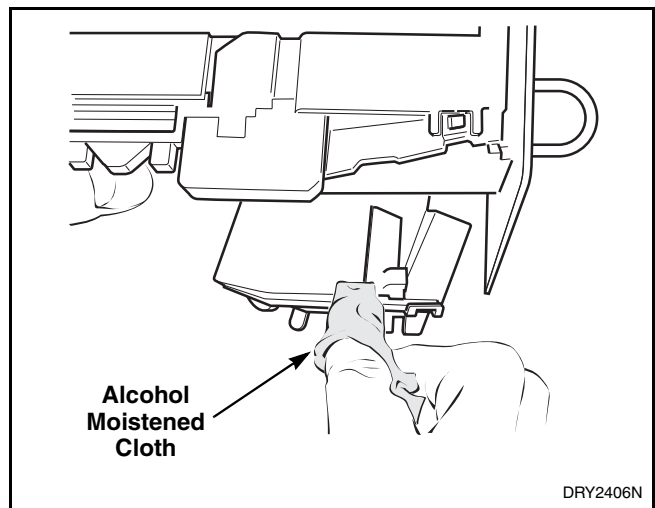

Figure 29



WARNING

To reduce the risk of electric shock, fire, explosion, serious injury or death:

- Disconnect electric power to the washer before servicing.
- Never start the washer with any guards/panels removed.
- Whenever ground wires are removed during servicing, these ground wires must be reconnected to ensure that the washer is properly grounded.
- Motor not grounded! Disconnect electric power before servicing motor.

W485

- f. Clean light sensors with a soft brush or air spray duster. Refer to *Figure 30*.

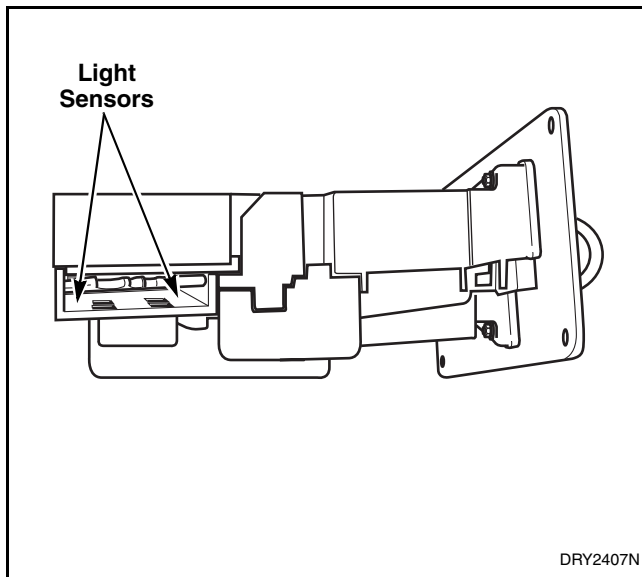

Figure 30

- g. Close cover for coin drop.
- h. **Coin Drops with OLD-Style Spring** - Move spring back over cover catch.
- i. Reinstall coin drop into machine.
- j. Reconnect electrical power to machine and drop.
- k. Add a coin to drop to verify that coin drop is operating properly and that electrical connection is working properly.