

Commercial Stacked Washer/ Dryers

Refer to Page 6 for Model Numbers

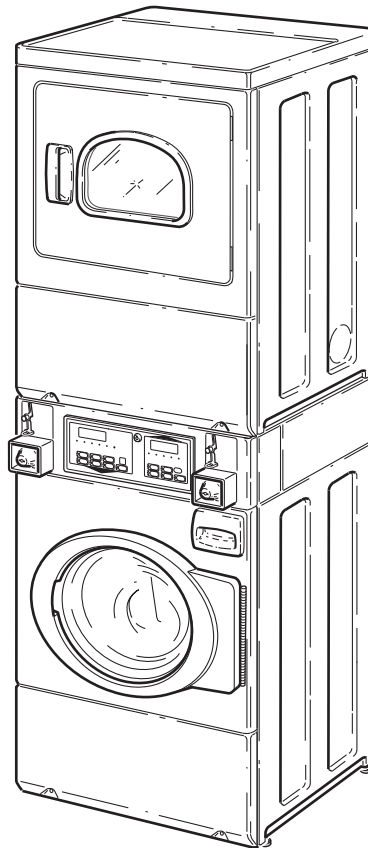

SWD453C

Table of Contents

Section 1 – Safety Information	3
Locating an Authorized Servicer	4
Section 2 – Introduction	5
Customer Service.....	5
Nameplate Location.....	5
Model Identification	6
Theory of Operation	7
Section 3 – General Troubleshooting.....	10
1. Troubleshooting Coin Drop	10
2. Washer Motor Circuit	14
3. Troubleshooting Knocking Noise	14
5. Troubleshooting LEDs on Washer Inverter Controls Starting Machine Serial No. 0911014603.....	16
6. No Spin (Washer).....	16
Section 4 – Dryer Troubleshooting	18
7. Dryer Motor Does Not Run	19
8. Dryer Stops In Cycle; Quits After The First Few Loads; Has A Burning Smell; Cycles On Motor Thermal Protector	20
9. Dryer Motor Runs But Cylinder Does Not Turn	21
10. Dryer Motor Does Not Stop.....	22
11. Dryer Runs Only When Door is Open.....	23
12. Dryer Heating Assembly Does Not Heat or Burner Does Not Ignite	24
13. Igniter Does Not Glow (Gas Supply Sufficient) – Gas Dryer Models	26
14. Burner Ignites and Goes Out Repeatedly – Gas Dryer Models	27
15. Igniter Glows But Burner Does Not Ignite – Gas Dryer Models	28
16. Dryer Heater Assembly Or Burner Shuts Off Prematurely	29
17. Dryer Heater Assembly or Burner Repeatedly Cycles Off On Limit Thermostat	30
18. Dryer Heater Assembly or Burner Does Not Shut Off.....	32
19. Clothes Do Not Dry in Dryer.....	33
20. Clothes Are Too Hot When Removed From Dryer	34
21. Excessive Chattering Or Vibrating Noise in Dryer	35
22. Excessive Humming Or Whistling Noise in Dryer.....	36
Section 5 – Washer Electronic Control Troubleshooting	37
23. Error Code Listing	37
24. PDA Does Not Communicate With Control.....	40
25. Coins Ignored When Entered.....	41
26. No Visible Display on Control.....	42
27. Washer Will Not Start – “door” Displayed.....	44
28. Washer Will Not Start – “E dL” on Display	46

© Copyright 2010, Alliance Laundry Systems LLC

All rights reserved. No part of the contents of this book may be reproduced or transmitted in any form or by any means without the expressed written consent of the publisher.

29. Washer Will Not Fill (Machine Empty, No “E SP” on Display).....	48
30. Washer Overflows.....	50
31. Pump or Drain Valve Does Not Operate	52
32. Serial Communication Error (“E SP” on Display).....	54
33. Motor Does Not Run (“E dF” on Display)	56
34. Washer Will Not Heat (Models Equipped with Heater) (“E oP” or “E SH” Displayed)	58
35. Washer Will Not Heat (Models Equipped with Heater) (3 Phase Heater Machines Only)	60
Section 6 – Dryer Electronic Control Troubleshooting.....	62
36. Error Codes	63
37. Coins Ignored When Entered	64
38. No IR Communication	65
39. No Display	66
40. Door Open.....	68
41. Motor Will Not Start	70
42. No Heat (Electric)	72
43. No Heat (Gas)	74
Section 7 – Adjustments	76
44. Cabinet Leveling Legs	76
45. Washer Loading Door	77
46. Washer Motor Belt Tension.....	78
47. Washer Door Catch.....	79
48. Shipping Braces	81
49. Burner Flame (Gas Models).....	82
50. Cleaning Non-Electronic Coin Drop.....	83
51. Cleaning Electronic Coin Drop.....	85
Section 8 – Dryer Test Procedures	88
52. Drive Motor.....	88
53. Motor Switch.....	91
54. Burner System Operation.....	93
55. Electrical Circuit To Ignition System (Gas Models)	94
56. Gas Valve Coils Check (Gas Models)	94
57. Sensor Check (Gas Models).....	95
58. Igniter Check (Gas Models)	95
59. Thermal Fuse (Electric Models)	96
60. Heater Assembly (Electric Models).....	96
61. Cycling or Limit Thermostat.....	96
62. Door Switch	97
Section 9 – Internal Wiring of Dryer Motor Switch.....	98

Section 1

Safety Information

Throughout this manual and on machine decals, you will find precautionary statements (“CAUTION,” “WARNING” and “DANGER”) followed by specific instructions. These precautions are intended for the personal safety of the operator, user, servicer, and those maintaining the machine.

▲ DANGER

Danger indicates an imminently hazardous situation that, if not avoided, will cause severe personal injury or death.

WARNING

Warning indicates a hazardous situation that, if not avoided, could cause severe personal injury or death.

CAUTION

Caution indicates a hazardous situation that, if not avoided, may cause minor or moderate personal injury or property damage.

Additional precautionary statements (“IMPORTANT” and “NOTE”) are followed by specific instructions.

IMPORTANT

The word “IMPORTANT” is used to inform the reader of specific procedures where minor machine damage will occur if the procedure is not followed.

NOTE

The word “NOTE” is used to communicate installation, operation, maintenance or servicing information that is important but not hazard related.

In the interest of safety, some general precautions relating to the operation of this machine follow.

	<h2>WARNING</h2>
<ul style="list-style-type: none">• Failure to install, maintain, and/or operate this machine according to the manufacturer’s instructions may result in conditions which can produce serious injury, death and/or property damage.• Do not repair or replace any part of the machine or attempt any servicing unless specifically recommended or published in this Service Manual and that you understand and have the skills to carry out.• Whenever ground wires are removed during servicing, these ground wires must be reconnected to ensure that the machine is properly grounded and to reduce the risk of fire, electric shock, serious injury, or death.	
<small>W284</small>	



WARNING

To reduce the risk of electric shock, fire, explosion, serious injury or death:

- Disconnect all electric power to the machine and accessories before servicing.
- Close gas shut-off valve to gas dryer before servicing.
- Never start machine with any guards/panels removed.
- Whenever ground wires are removed during servicing, these ground wires must be reconnected to ensure that the machine is properly grounded.
- Washer motor not grounded! Disconnect electric power before servicing motor.

W502



WARNING

Repairs that are made to your products by unqualified persons can result in hazards due to improper assembly or adjustments subjecting you or the inexperienced person making such repairs to the risk of serious injury, electrical shock or death.

W007



WARNING

If you or an unqualified person perform service on your machine, you must assume the responsibility for any personal injury or property damage which may result. The manufacturer will not be responsible for any injury or property damage arising from improper service and/or service procedures.

W286

NOTE: The WARNINGS and IMPORTANT INSTRUCTIONS appearing in this manual are not meant to cover all possible conditions and situations that may occur. Common sense, caution and care must be exercised when installing, maintaining or operating the machine.

Always contact your dealer, distributor, service agent or the manufacturer about any problems or conditions you do not understand.

Locating an Authorized Servicer

Alliance Laundry Systems is not responsible for personal injury or property damage resulting from improper service. Review all service information before beginning repairs.

Warranty service must be performed by an authorized technician, using authorized factory parts. If service is required after the warranty expires, Alliance Laundry Systems also recommends contacting an authorized technician and using authorized factory parts.

Section 2

Introduction

Customer Service

If literature or replacement parts are required, contact the source from whom the machine was purchased or contact Alliance Laundry Systems at (920) 748-3950 for the name and address of the nearest authorized parts distributor.

For technical assistance, call either of the numbers listed below:

(920) 748-3121 Ripon, Wisconsin

+32 56 41 20 54 Wevelgem, Belgium

Nameplate Location

When calling or writing about your product, be sure to mention model and serial numbers. Model and serial numbers are located on nameplate(s) as shown.

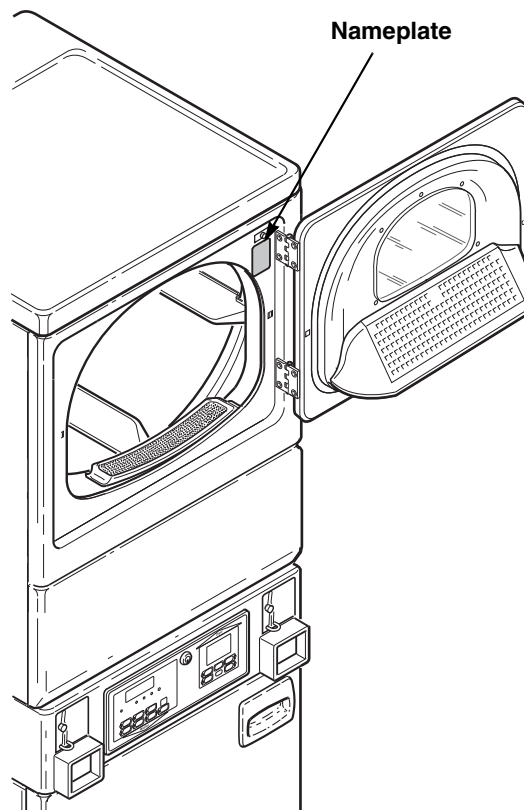

SWD1165P

Introduction

Model Identification

Information in this manual is applicable to these washer/dryer models.

BT3LLFSG401UN01
BT3LLFSG401UW01
BT3LLFSP401UN01
BT3LLFSP401UW01
BT3LXFSG401UN01
BT3LXFSG401UW01
BT3LXFSP401UN01
BT3LXFSP401UW01
HTELYFSP281CW01
HTELYFSP291CW01
HTELYFSP281CW01
HTELYFSP291CW01
HTGLXFSP091CW01

JT1DEFSP411EW01
JT1DGFSP411EW01
JT1DMFSG411EN01
JT2DEFSP411EW01
JT2DGFSP411EW01
JT2DMFSG411EN01
JTEDEFSP301EW01
JTGDEFSP301EW01
NT1LXFSP401UN01
NT1LXFSP401UW01
NT2LLFSP401UN01
NT2LLFSP401UW01
NT2LXFSP401UN01
NT2LXFSP401UW01
NT3LLFSP401UN01
NT3LLFSP401UW01
NT3LXFSP401UN01
NT3LXFSP401UW01
NTHLXFSP571NW01
NTHLYFSP571NW01

STELCFSP171TW01
STELXFSP171TW01
STELYFSP171TW01
STGLCFSP111TW01
STGLCFSP111TWNA
STGLXFSG111TW01
STGLXFSP111TW01
STGLYFSP111TW01
STGLYFSP111TWNA

Introduction

General (Dryer)

The dryer uses heated air to dry loads of laundry. When the motor is started, the exhaust fan pulls fresh air in through louvers at the rear of the dryer and over the heat source (burner flame for gas and heating element for electric). The heated air moves through the heater duct and into the cylinder, where it circulates through the wet load. The air then passes through the lint filter, air duct and exhaust fan, where it is vented to the outdoors.

General (Washer)

This frontload washer provides some of the same principles of operation as the typical topload washers. It senses water level, it dispenses the desired laundry detergent, agitates the clothes for good cleaning action, removes the water out of the washer and spins the clothing in preparation for the dryer.

The difference in operation is primarily the rotational washing agitation created for the horizontal basket and drum. This agitation tumbles the clothes in a clockwise, pause, and counter-clockwise direction. This reversing tumbling action provides an efficient washing process and requires less laundry detergent and less water.

The cycle begins by locking the loading door after the vend is satisfied. The type of cycle and water temperature are determined by the appropriate pads on the electronic control.

The inner basket starts agitating during the wash water fill. A column of air is trapped in a pressure bulb and hose. The air pressure continues to increase as the inner basket fills with water until it is great enough to activate the pressure switch which then causes the wash fill to stop.

The agitate cycle tumbles the clothing in a clockwise direction for a period of 15 seconds, pauses for nine seconds and then tumbles the clothing in a counterclockwise direction for 15 seconds. This agitation continues until the end of the wash cycle. The machine stops agitating and turns on the pump or drain valve which removes the wash water.

Upon completion of the wash cycle, the machine goes into a rinse cycle. Fresh cold water is brought into the inner basket via the mixing valve until the pressure switch shuts off the water while agitating. The rinse cycle consists of agitation for a predetermined amount of time then a spin mode with the pump running where the machine goes into a series of 4 short 500 RPM spins. Two of these rinse cycles will normally take place with a third extra rinse cycle being optional. After all the rinse cycles have been completed, the

washer goes into a final high spin cycle to extract as much water as possible from the clothing to prepare them for the dryer. The spin speeds and duration of this final high spin cycle are determined by the type of wash cycle selected (refer to *Table 1* or *Table 2*).

NOTE: Washer may not reach 1000 RPM because of an out-of-balance condition. Control may limit speed to 850, 650 or 500 RPM depending on severity of out-of-balance condition.

Models Through Serial No. 0911014602

	Regular	Perm Press	Delicate
650 RPM	3 minutes	4 minutes	4 minutes
1000 RPM	3 minutes	2 minutes	0 minutes

Table 1

Models Starting Serial No. 0911014603

	Regular	Perm Press	Delicate
500 RPM	0 minutes	0 minutes	4 minutes
650 RPM	3 minutes	6 minutes	0 minutes
1000 RPM	3 minutes	0 minutes	0 minutes

Table 2

Technical (Washer)

The basic operational system of this washer consists of the electronic control, the inverter control, pressure switch, water valves, electric pump (or drain valve) and A.C. motor.

The electronic control performs all control and timing functions like the timer in a topload washer. The electronic control sends simple speed and output commands to the inverter control via serial communication. The electronic control powers the door lock, pump (or drain valve) and the inverter control.

The inverter control powers the A.C. motor and performs all motor control functions. The inverter control also powers the water and dispenser valves and passes the pressure switch status to the electronic control. The inverter control is powered through the door switch, door lock switch and electronic control. The inverter control also alerts the electronic control to any errors in the motor.

The inverter control uses a speed sensor on the motor to measure the drum RPM. Before entering any spin step the inverter control measures the RPM of the drum to sense out-of-balance. The inverter control will try to redistribute the clothes if an out-of-balance condition exists the inverter control will limit the spin speed to several speeds depending on the severity of the out-of-balance condition. If the out-of-balance condition is severe enough the inverter control will limit speed to 90 RPM and will not spin.

NOTE: An additional out-of-balance switch is used to detect any out-of-balance condition during spins. If this switch opens during a spin step, the inverter control immediately stops and then restarts the spin.

Section 3

General Troubleshooting



WARNING

To reduce the risk of electric shock, fire, explosion, serious injury or death:

- Disconnect all electric power to the machine and accessories before servicing.
- Close gas shut-off valve to gas dryer before servicing.
- Never start machine with any guards/panels removed.
- Whenever ground wires are removed during servicing, these ground wires must be reconnected to ensure that the machine is properly grounded.
- Washer motor not grounded! Disconnect electric power before servicing motor.

W502

1. Troubleshooting Coin Drop

a. Non-Electronic Coin Drops:

When coin is placed into coin slot, the coin should roll down drop and be heard dropping into coin vault. If coin does not fall into coin vault or if coin drop sensor does not register that coin has been entered, follow troubleshooting instructions on following page. Refer to *Figure 1* for path that coin follows when working properly.

IMPORTANT: Never use oil to correct coin drop problems. Oil residue will prevent coins from rolling properly.

IMPORTANT: Do not bend or damage mechanical parts within coin drop.

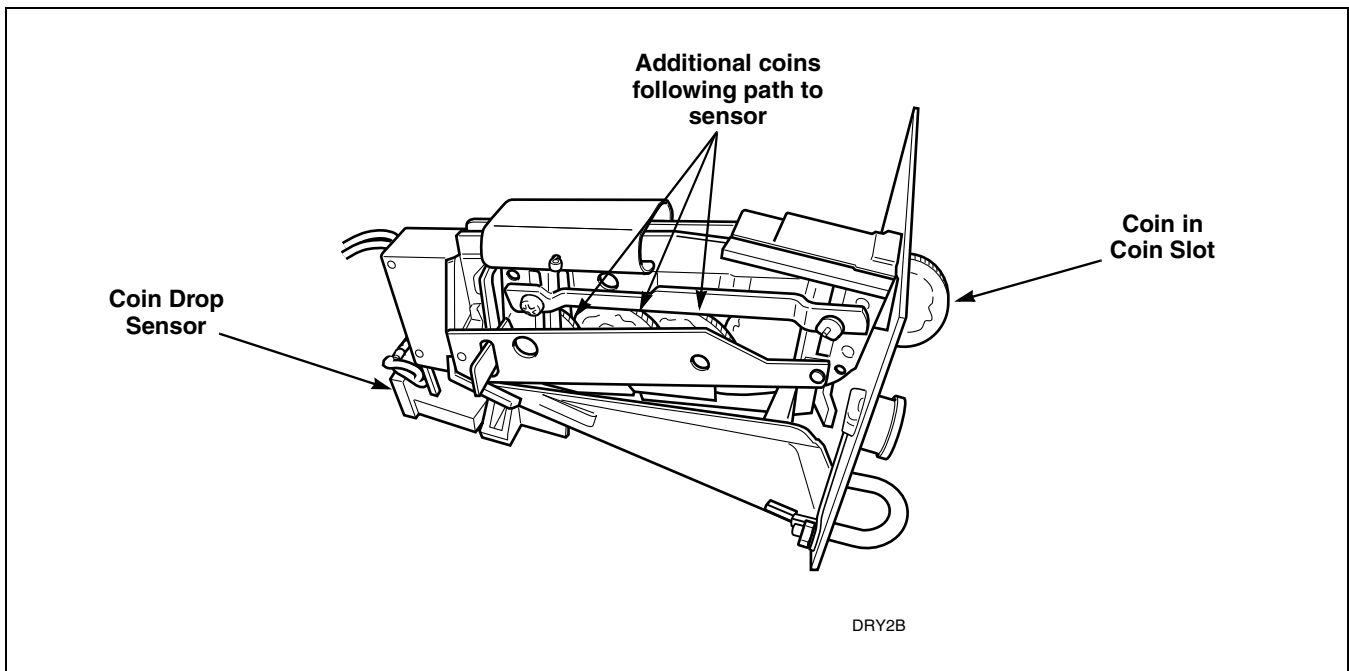
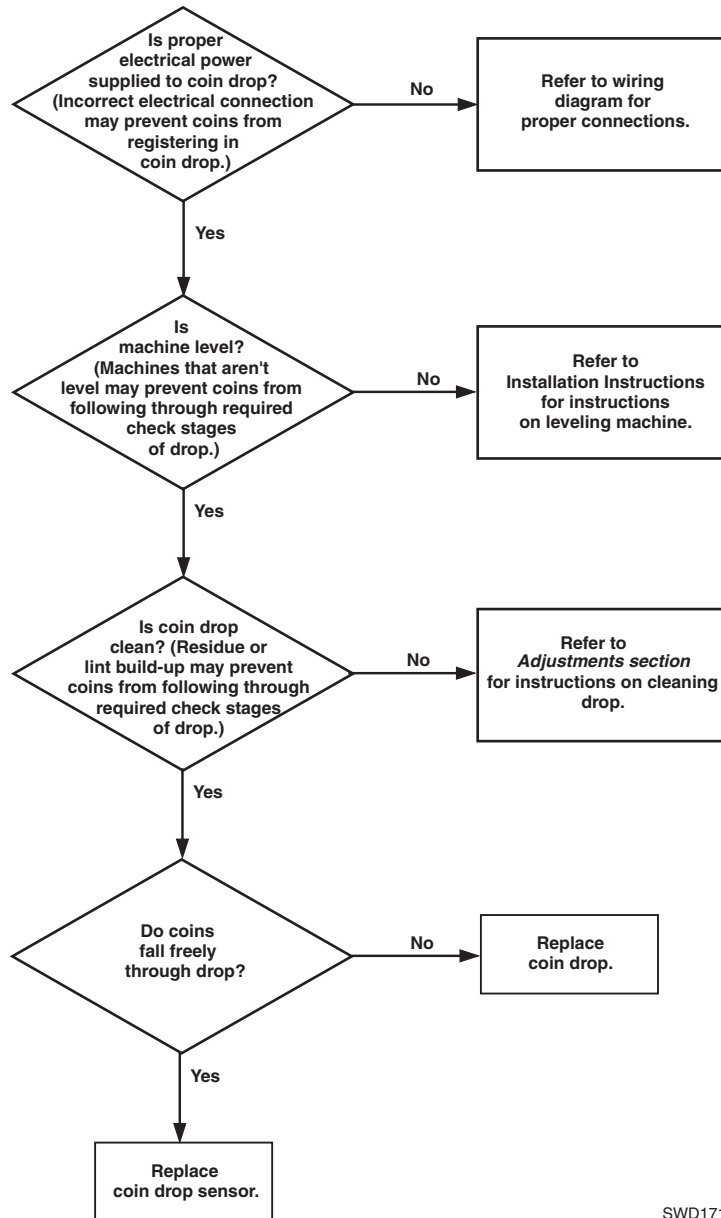

Figure 1

Troubleshooting Coin Drop



SWD1714S

General Troubleshooting

b. Electronic Coin Drops:

If coin drop is not accepting coins, perform the following:

- (1) Clean coin drop. Refer to *Paragraph 55*.
- (2) On electronic coin drops with an old-style tension spring (shown in *Figure 2* and *Figure 4*), test and replace tension spring using the following instructions.

Remove Coin Drop From Machine

- (1) Disconnect electrical power to machine and drop.
- (2) Remove coin drop from machine.

Test Tension Spring

- (1) Push coin return button to open and close coin drop cover to clear possible coin jams. Refer to *Figure 2*.

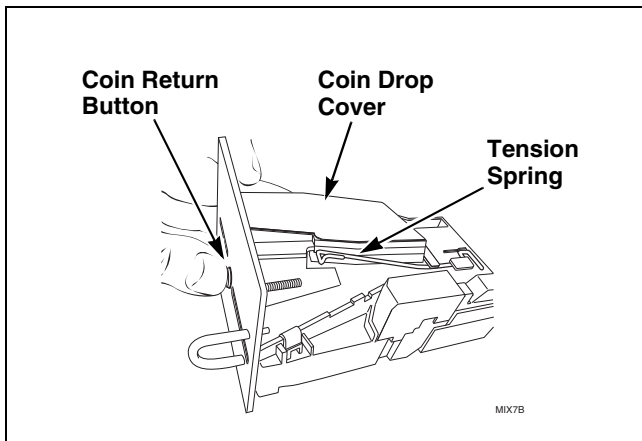

Figure 2

- (2) Manually hold down coin drop cover and insert coin. Refer to *Figure 3*.

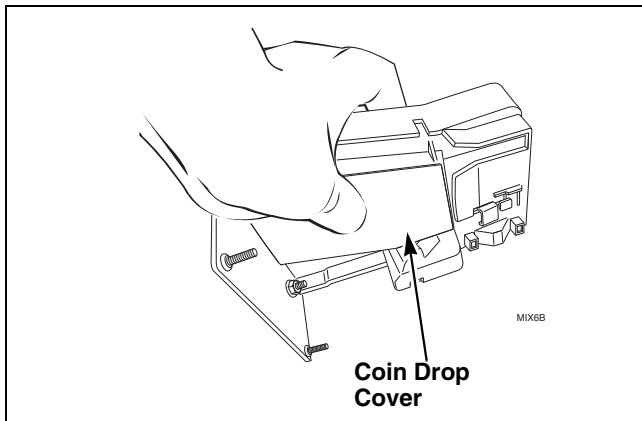

Figure 3

- (3) If coin drop now operates properly, replace tension spring using instructions on following pages.

Replace Tension Spring

- (1) Move tension spring downward until cover catch is free. Refer to *Figure 4*.

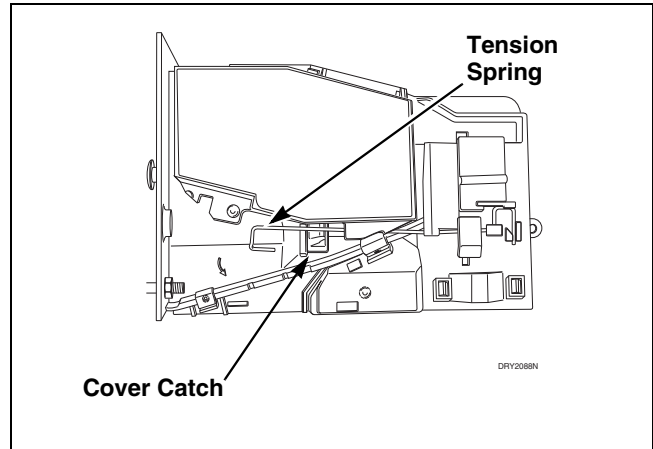

Figure 4

- (2) Open cover for coin drop.
- (3) Place a small flathead screwdriver under right side of tension spring and lift up. Refer to *Figure 5*.

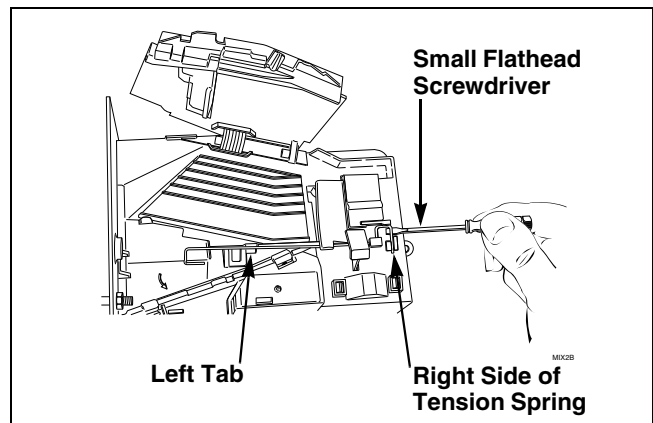

Figure 5

- (4) Use screwdriver to move spring approximately 3 mm to left.
- (5) Lift spring over left tab. Refer to *Figure 5*.

- (6) Rotate spring clockwise, 40 to 60 degrees, until it is free from right tabs. Refer to *Figure 6*.

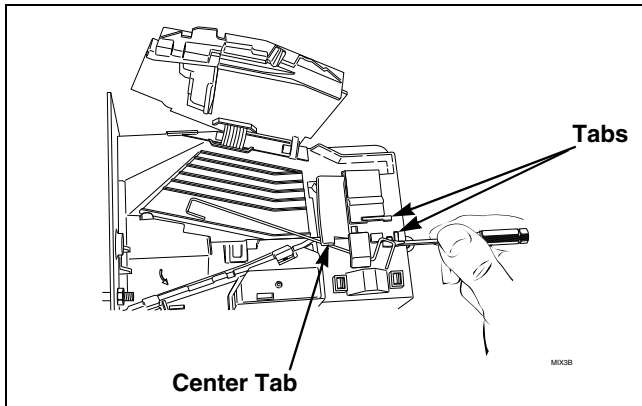

Figure 6

- (7) Use screwdriver to remove spring from center tab. Refer to *Figure 6*.
- (8) Lift spring, with attached clip, off drop.
- (9) Remove clip from spring. Refer to *Figure 7*.

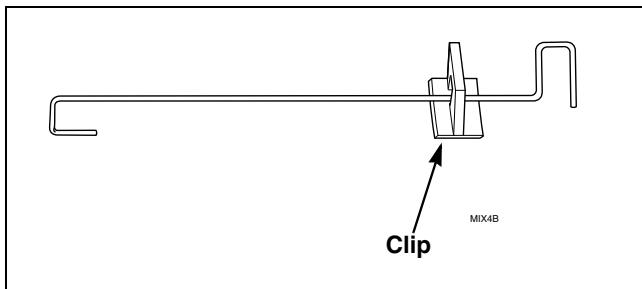

Figure 7

- (10) Attach clip to new tension spring, Part No. 209/00598/02.
- (11) Place clip, installed on spring, in slot on coin drop. Refer to *Figure 8*.

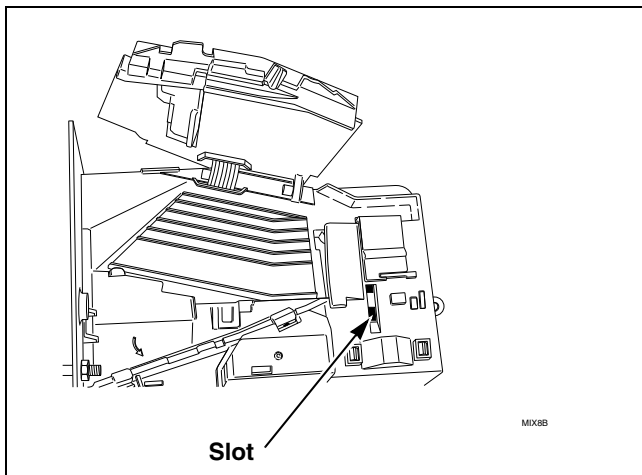

Figure 8

- (12) Use a small flathead screwdriver to push spring under center tab. Refer to *Figure 9*.

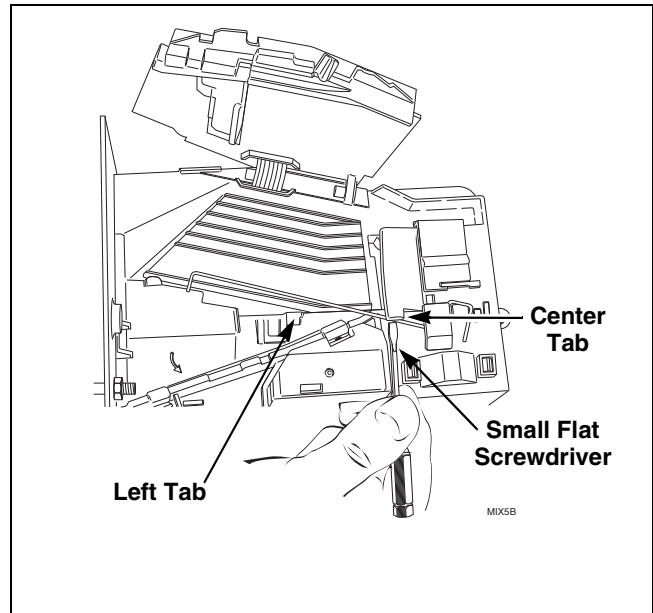

Figure 9

- (13) Lift spring gently to place in position under left tab.
- (14) Push spring to right until it snaps into position. Refer to *Figure 5*.
- (15) Close coin drop cover.
- (16) Move tension spring over cover catch. Refer to *Figure 4*.

Reinstall Coin Drop Into Machine

- (1) Reinstall coin drop into machine.
- (2) Reconnect electrical power to machine and drop.
- (3) Add a coin to drop to verify that coin drop is operating properly and that electrical connection is working properly.



WARNING

- To reduce the risk of electric shock, fire, explosion, serious injury or death:
- Disconnect all electric power to the machine and accessories before servicing.
 - Close gas shut-off valve to gas dryer before servicing.
 - Never start machine with any guards/panels removed.
 - Whenever ground wires are removed during servicing, these ground wires must be reconnected to ensure that the machine is properly grounded.
 - Washer motor not grounded! Disconnect electric power before servicing motor.

W502

2. Washer Motor Circuit

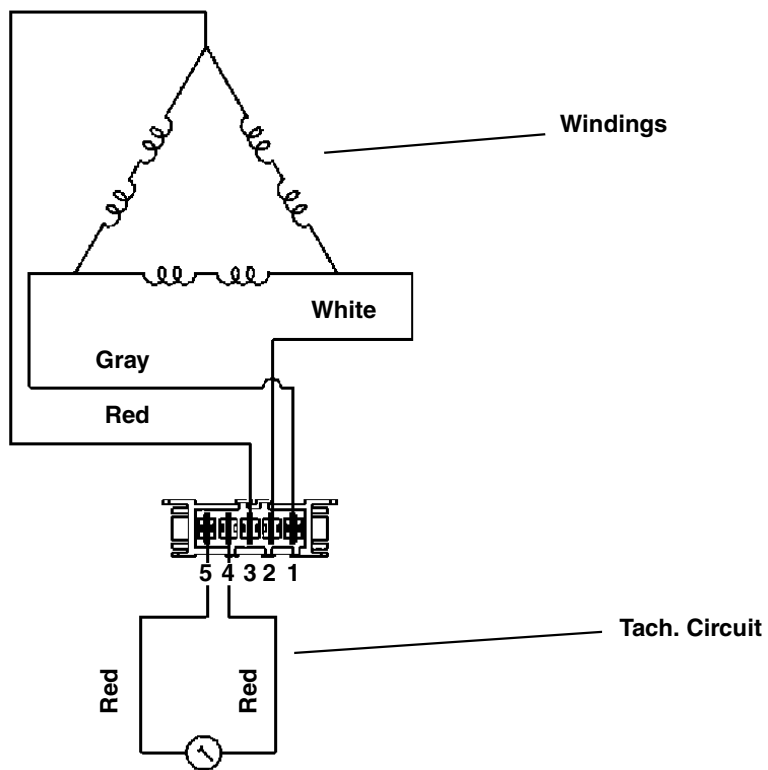

Resistance Values:

Tachometer Circuit:
 Terminals 4-5
 Approx. **115** ohms

Windings:

Terminals 1-2, 2-3, 1-3
 Approx. **4.5** ohms

3. Troubleshooting Knocking Noise

If a frontload washer produces a noise similar to a knock on a door, it might be due to a flat spot on the belt. The knocking sound is made when the flat spot hits the pulley. The knocking may occur

during a pulse spin and fade after reaching a higher RPM.

To correct this condition, replace the belt.



WARNING

To reduce the risk of electric shock, fire, explosion, serious injury or death:

- Disconnect all electric power to the machine and accessories before servicing.
- Close gas shut-off valve to gas dryer before servicing.
- Never start machine with any guards/panels removed.
- Whenever ground wires are removed during servicing, these ground wires must be reconnected to ensure that the machine is properly grounded.
- Washer motor not grounded! Disconnect electric power before servicing motor.

W502

4. No Spin Due to Out-of-Balance Switch Wiring Problem Starting Serial Nos. Beginning 0307

A “no spin” condition could be the result of an open circuit in the wire harness or out-of-balance switch. First, check that the harness is still connected to the out-of-balance switch. The out-of-balance switch is a **normally closed switch**. (continued)

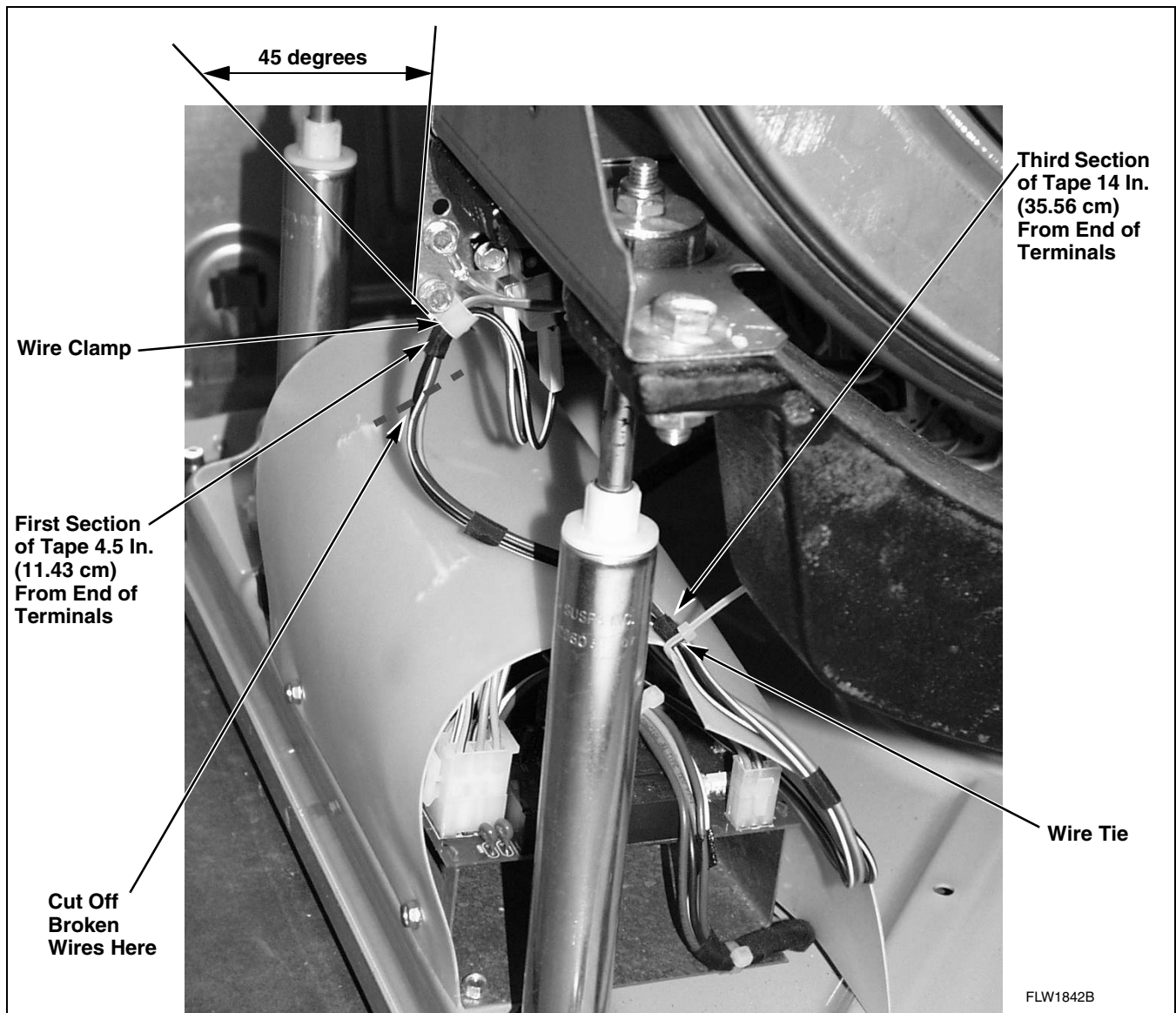

Figure 10



WARNING

To reduce the risk of electric shock, fire, explosion, serious injury or death:

- Disconnect all electric power to the machine and accessories before servicing.
- Close gas shut-off valve to gas dryer before servicing.
- Never start machine with any guards/panels removed.
- Whenever ground wires are removed during servicing, these ground wires must be reconnected to ensure that the machine is properly grounded.
- Washer motor not grounded! Disconnect electric power before servicing motor.

W502

If broken wires are found at the out-of-balance switch wire support, cut off portion of wires as shown in *Figure 10* and add new UL approved terminals.

- a. To test the electrical circuit, disconnect electrical power to the washer.
- b. Remove the “H1” connector from the inverter control assembly.
- c. Use an Ohm meter to check the black/white to violet/white wires. Circuit should read closed. An open reading indicates a bad switch or wire harness problem.
- d. Flex the harness at the plastic wire clamp and test continuity. If the base wire harness has an open circuit it **MUST** be replaced or the broken wires must be repaired with UL approved terminals.
- e. After replacing or repairing the wire harness, wrap electrical tape around wires in two locations as indicated below and in *Figure 10*. Then secure the harness wires to the original factory locations using clamp and wire tie. Refer to *Figure 10*.
 - (1) The plastic wire clamp should be angled toward the switch at 45 degrees.
 - (2) The clamp should wrap around the first section of tape on the harness, which should be placed approximately 4.5 inches (11.43 cm) from end of terminals.
 - (3) The harness should be secured to the inverter control shield with a wire tie.
 - (4) The tie should wrap around the third section of tape on the harness, which should be placed approximately 14 inches (35.56 cm) from end of terminals. Refer to *Figure 10*.

5. Troubleshooting LEDs on Washer Inverter Controls Starting Machine Serial No. 0911014603

There are three LEDs on the control to assist with troubleshooting (refer to *Figure 11*):

- Green LED on constant = 5VDC power supply present
- Green LED flashing one second on/one second off = inverter control power up
- Red LED flashing four times/second = inverter control is communicating with front end control

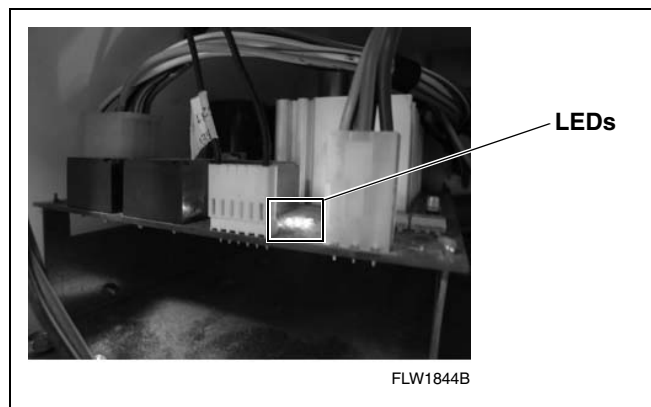

Figure 11

6. No Spin (Washer)

A no spin condition is not caused by intermittent operation of the motor or motor control (inverter assembly). **DO NOT** replace these components for no spin complaints if the unit passes the following procedure:



WARNING

- To reduce the risk of electric shock, fire, explosion, serious injury or death:
- Disconnect all electric power to the machine and accessories before servicing.
 - Close gas shut-off valve to gas dryer before servicing.
 - Never start machine with any guards/panels removed.
 - Whenever ground wires are removed during servicing, these ground wires must be reconnected to ensure that the machine is properly grounded.
 - Washer motor not grounded! Disconnect electric power before servicing motor.

W502

6. No Spin (continued)

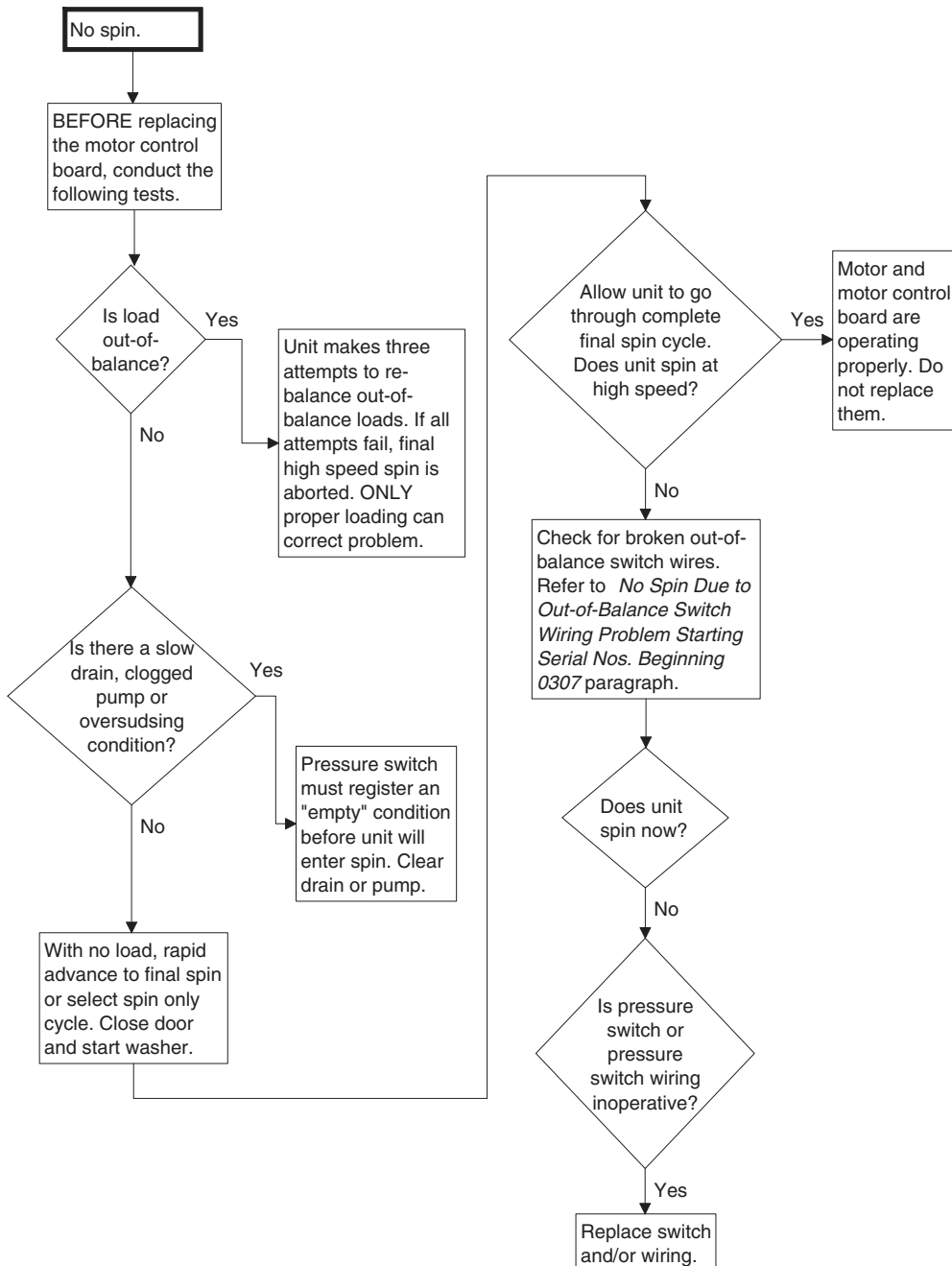

FLW1789S

Section 4

Dryer Troubleshooting



WARNING

To reduce the risk of electric shock, fire, explosion, serious injury or death:

- Disconnect all electric power to the machine and accessories before servicing.
- Close gas shut-off valve to gas dryer before servicing.
- Never start machine with any guards/panels removed.
- Whenever ground wires are removed during servicing, these ground wires must be reconnected to ensure that the machine is properly grounded.
- Washer motor not grounded! Disconnect electric power before servicing motor.

W502

IMPORTANT: Refer to wiring diagram for aid in testing dryer components.

7. Dryer Motor Does Not Run

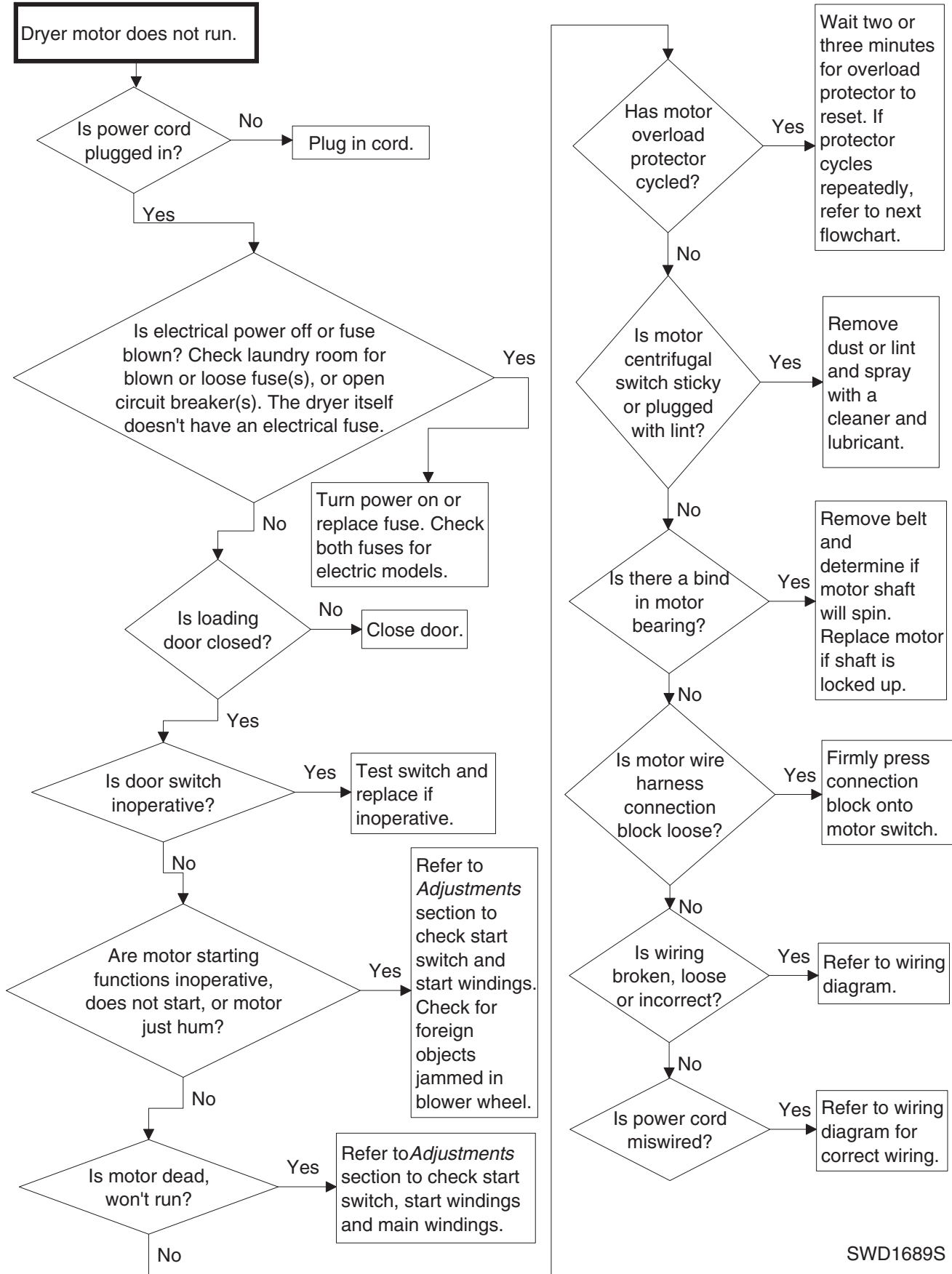

SWD1689S

8. Dryer Stops In Cycle; Quits After The First Few Loads; Has A Burning Smell; Cycles On Motor Thermal Protector

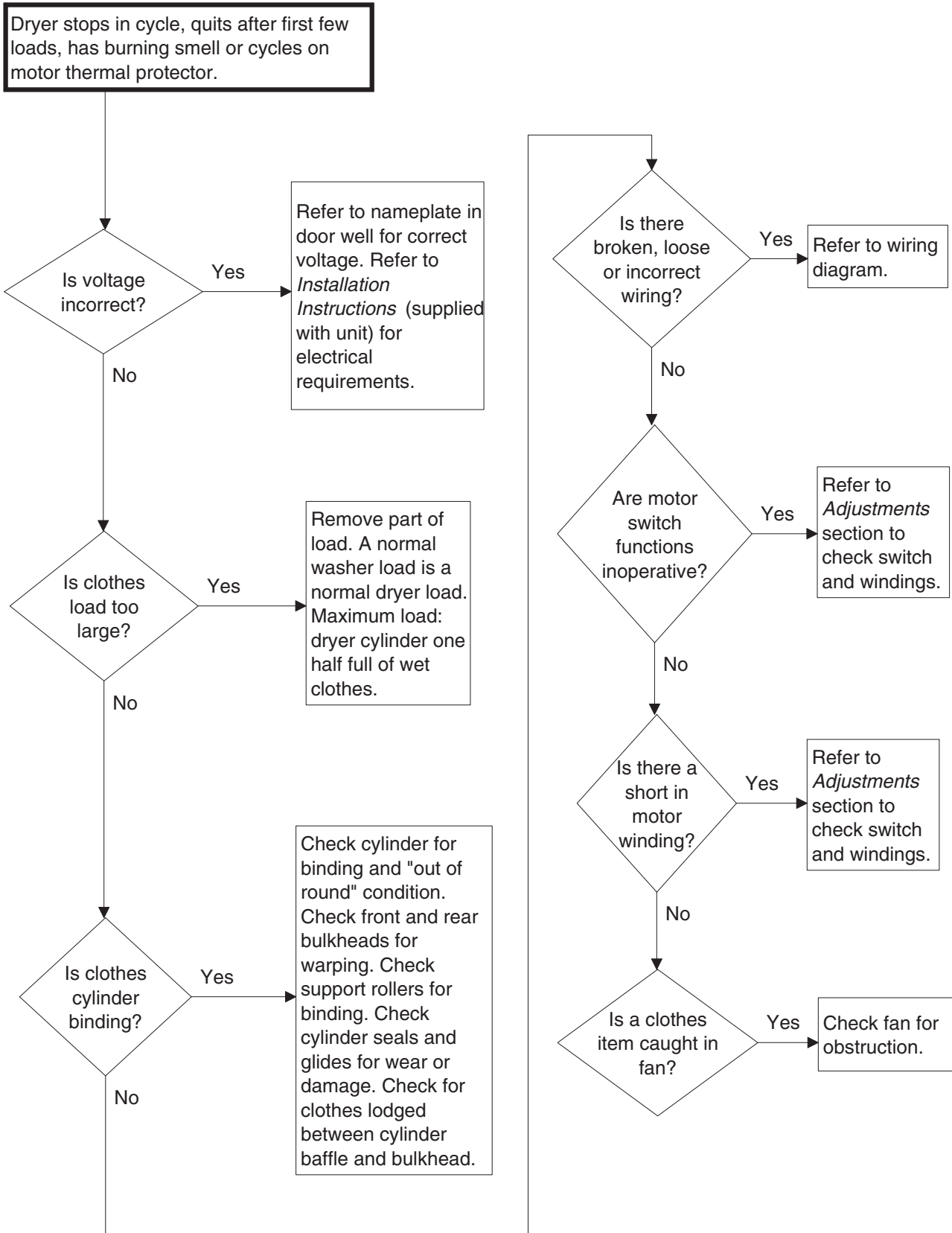

SWD1690S

9. Dryer Motor Runs But Cylinder Does Not Turn

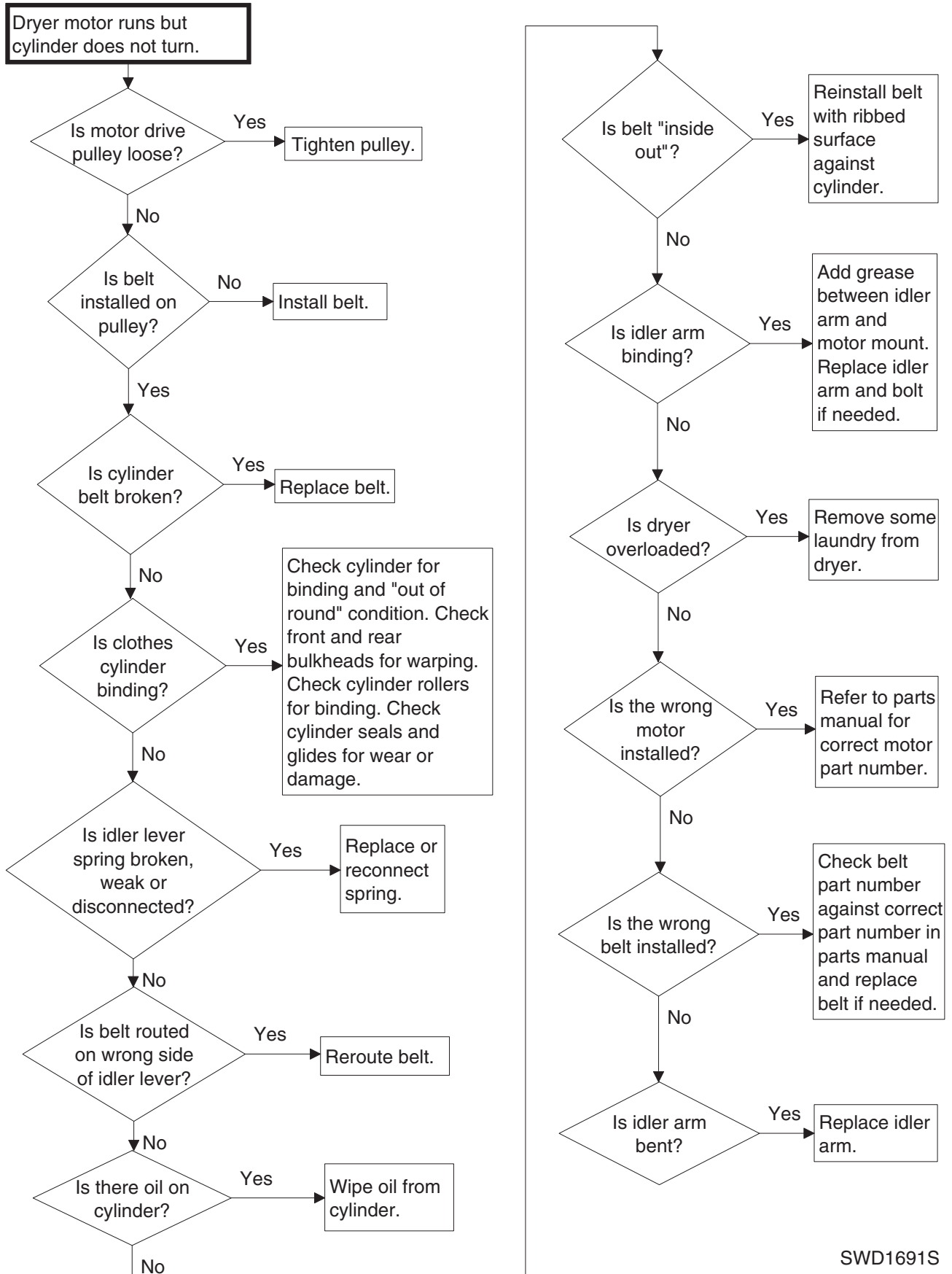

10. Dryer Motor Does Not Stop

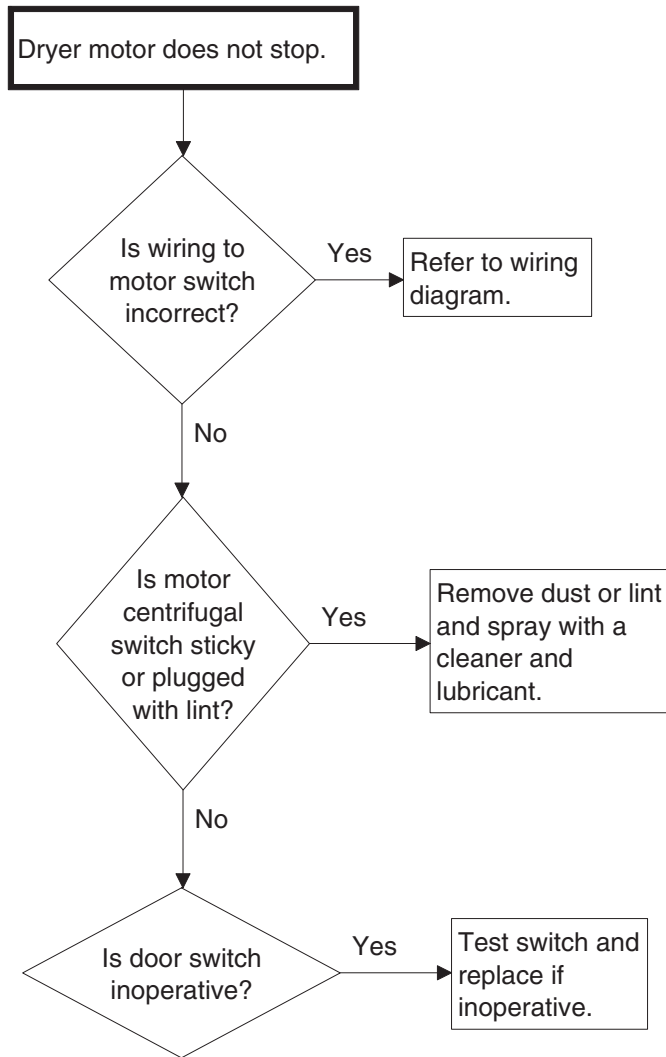

SWD1692S

11. Dryer Runs Only When Door is Open

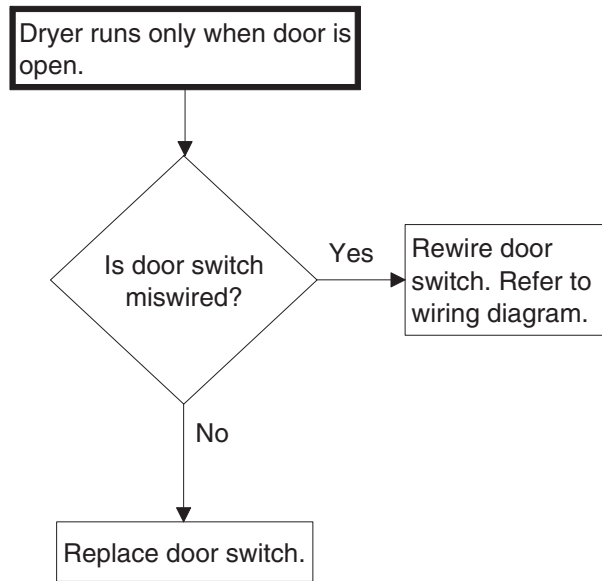

SWD1693S

12. Dryer Heating Assembly Does Not Heat or Burner Does Not Ignite

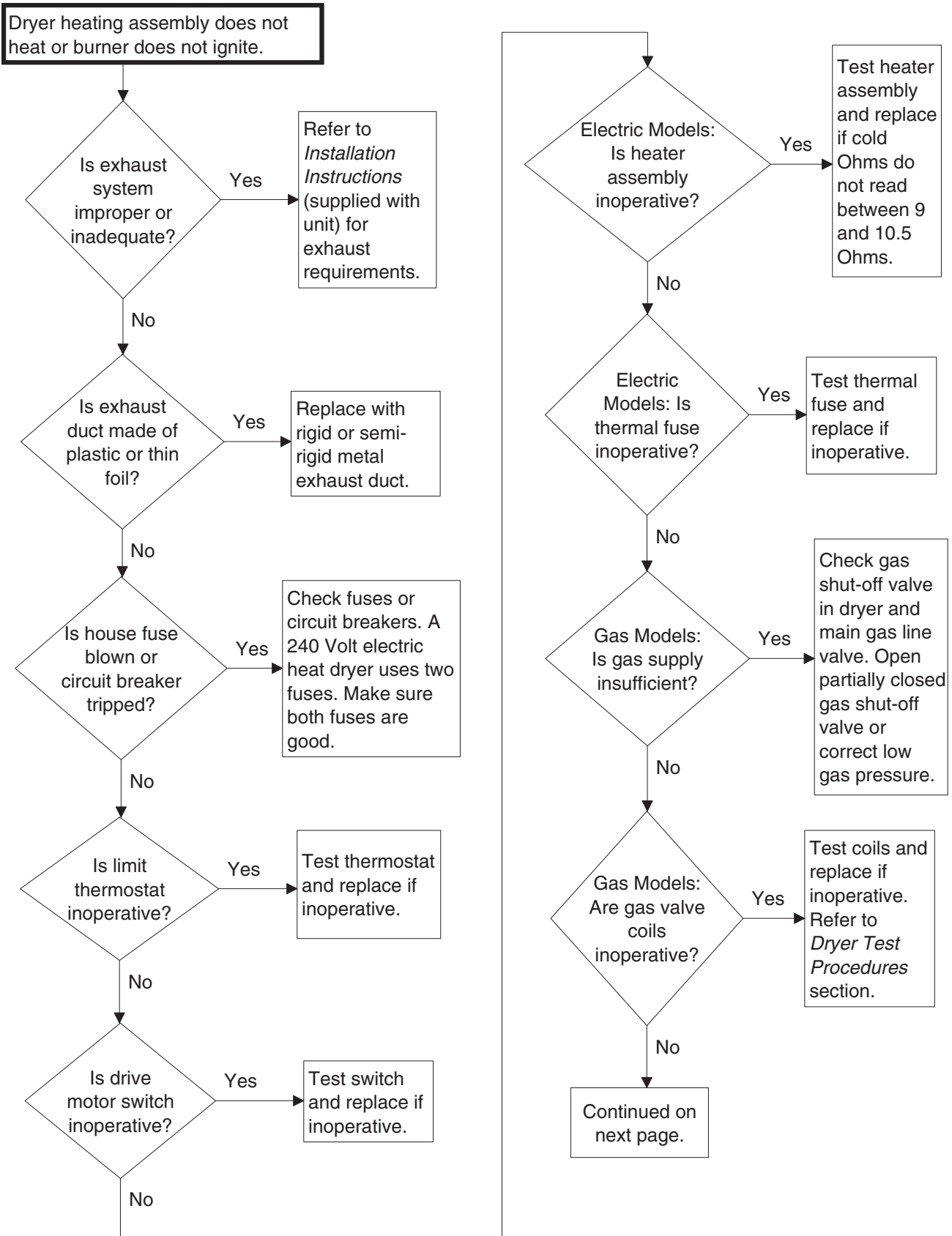

SWD1694S-a

12. Dryer Heating Assembly Does Not Heat or Burner Does Not Ignite (continued)

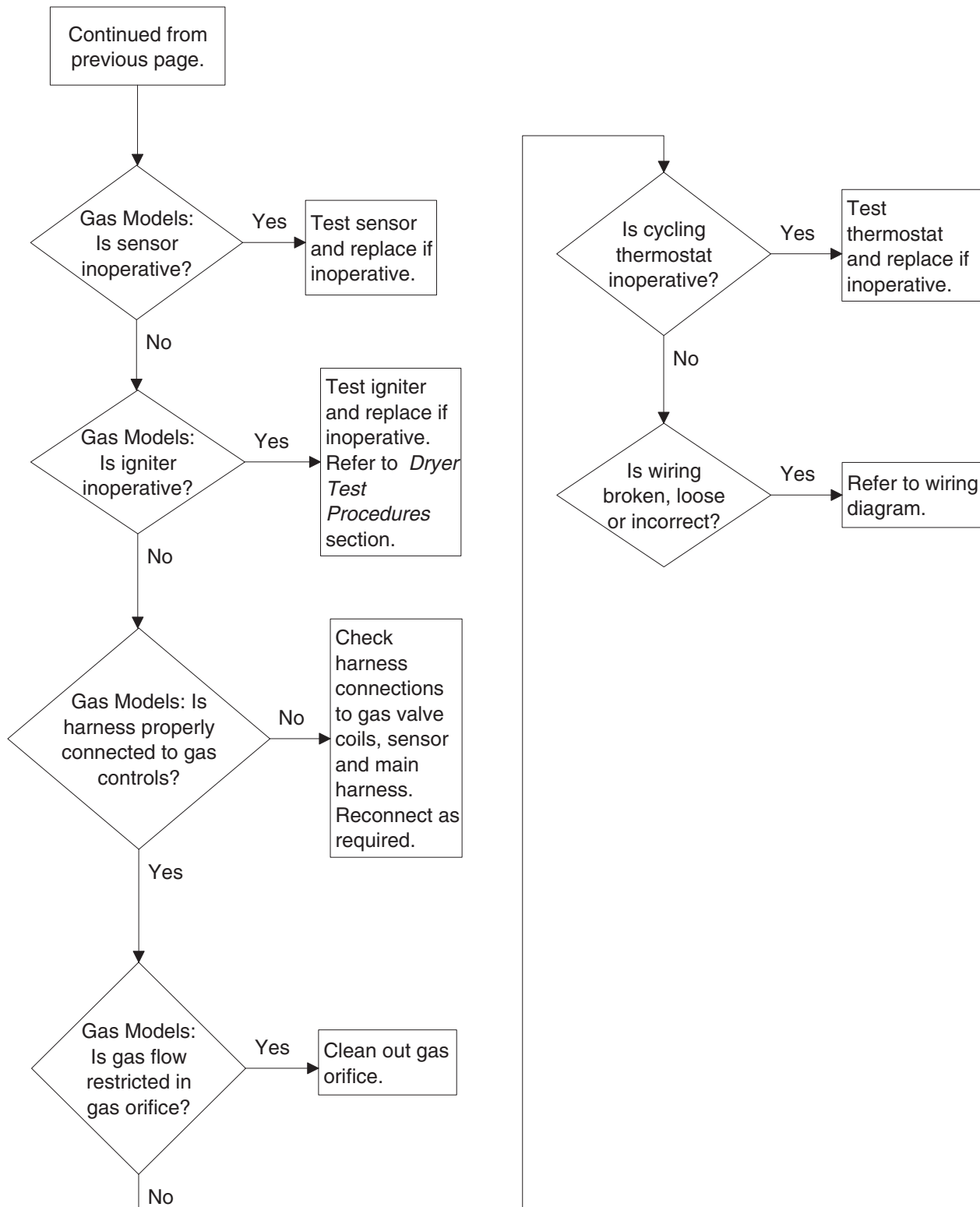

SWD1694S-b

13. Igniter Does Not Glow (Gas Supply Sufficient) – Gas Dryer Models

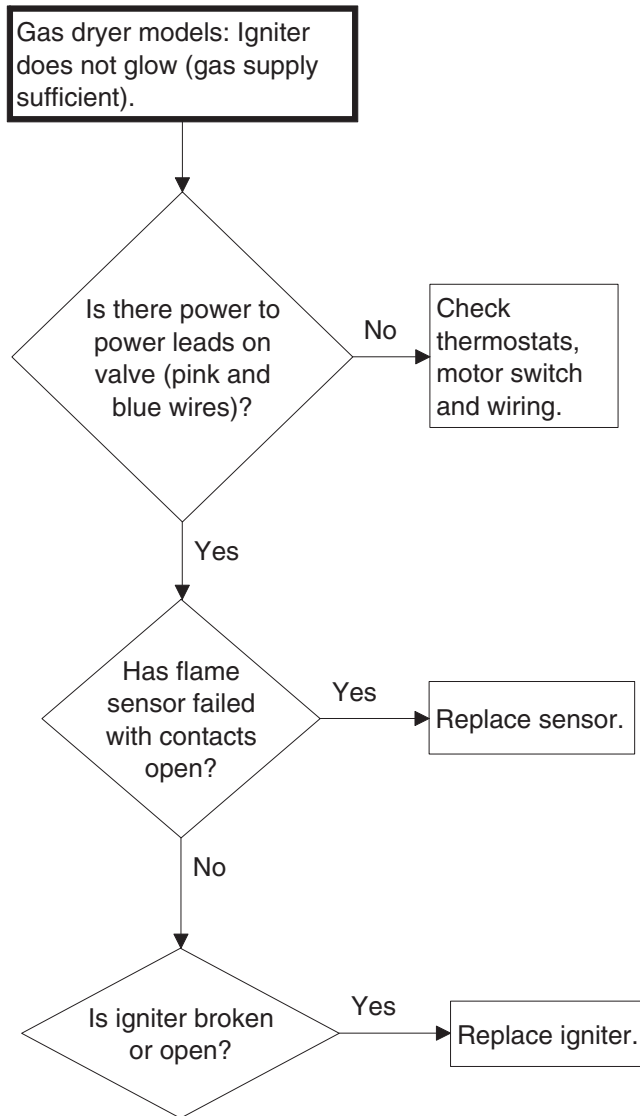

SWD1695S

14. Burner Ignites and Goes Out Repeatedly – Gas Dryer Models

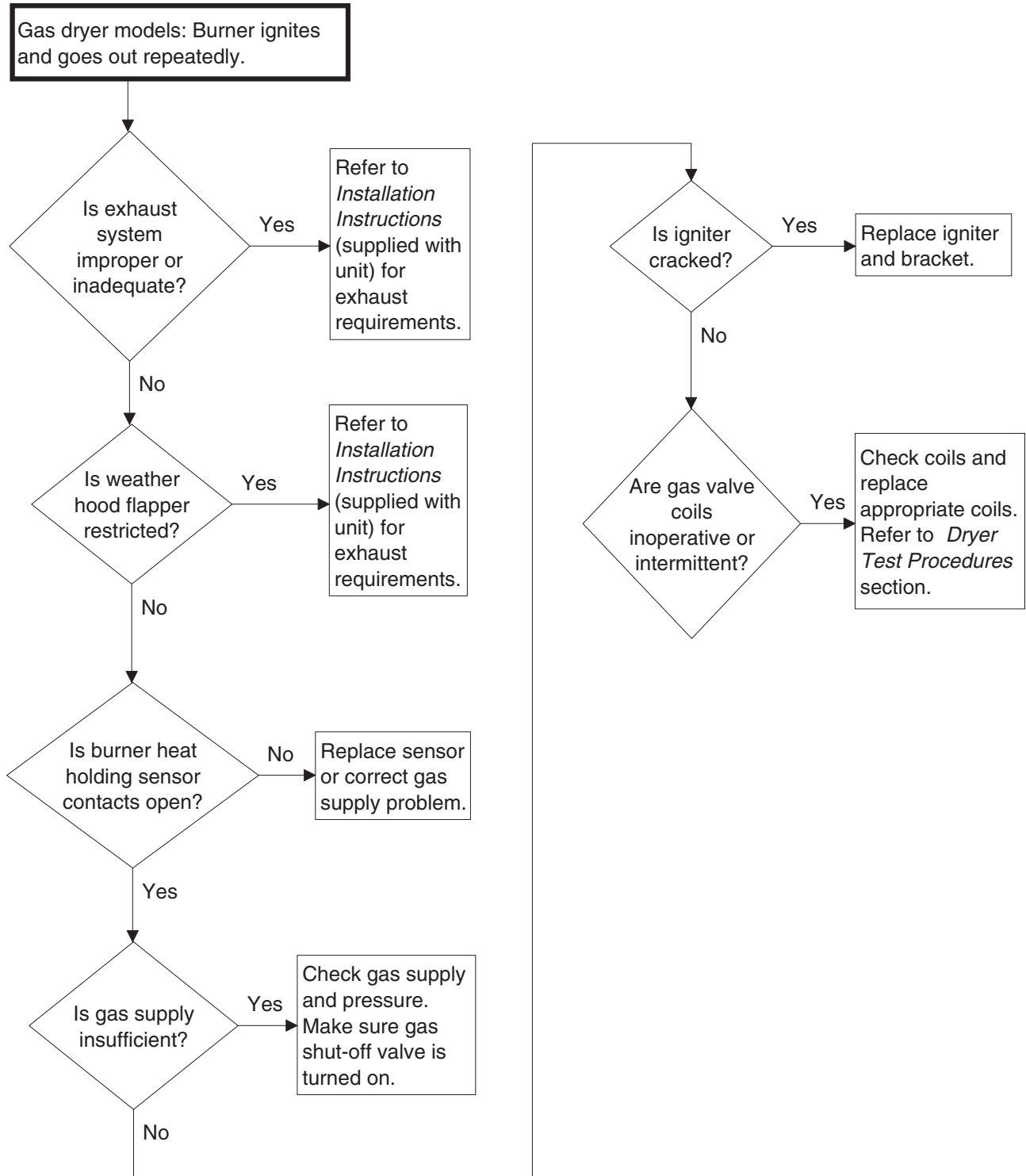

SWD1696S

15. Igniter Glows But Burner Does Not Ignite – Gas Dryer Models

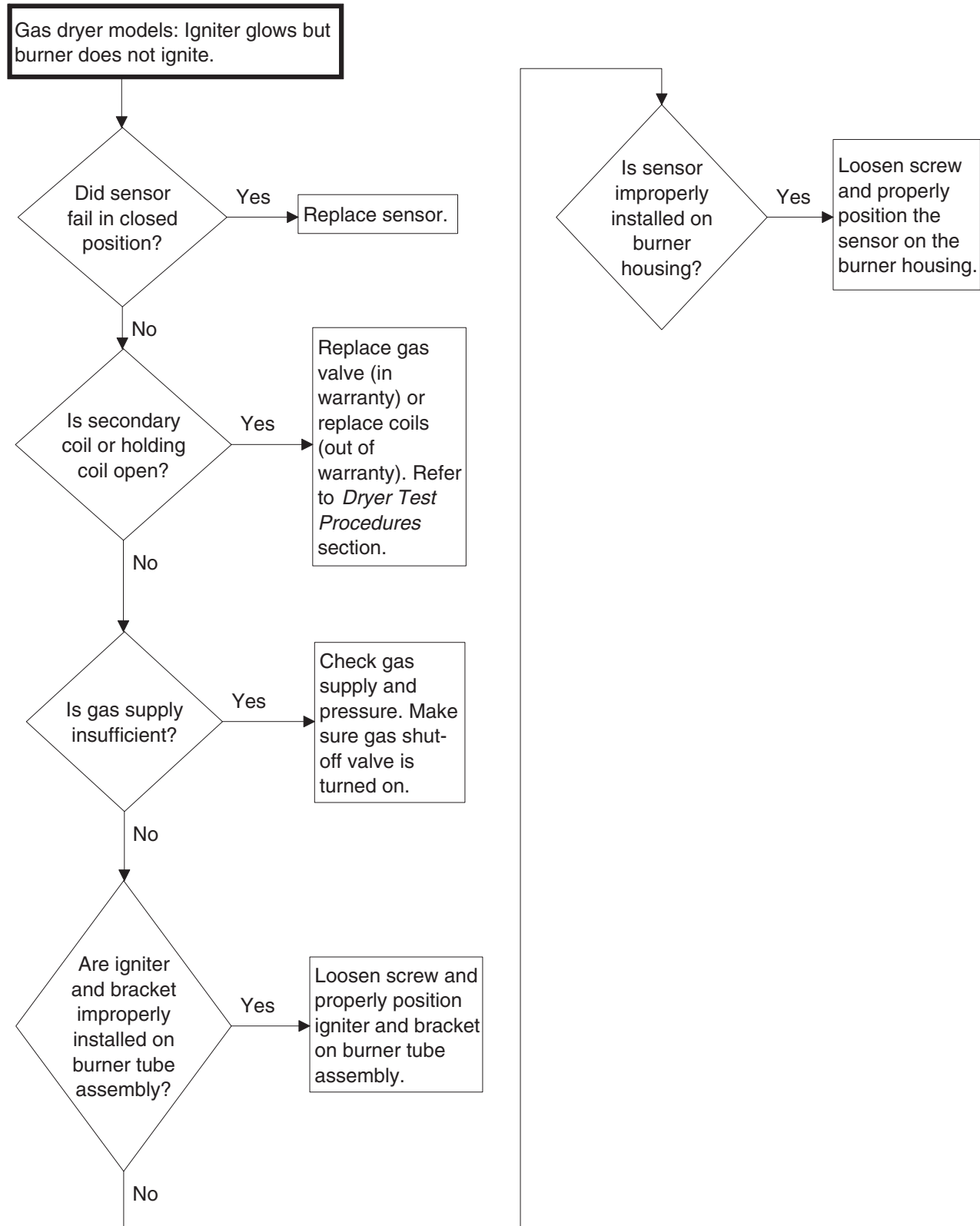

SWD1697S

16. Dryer Heater Assembly Or Burner Shuts Off Prematurely

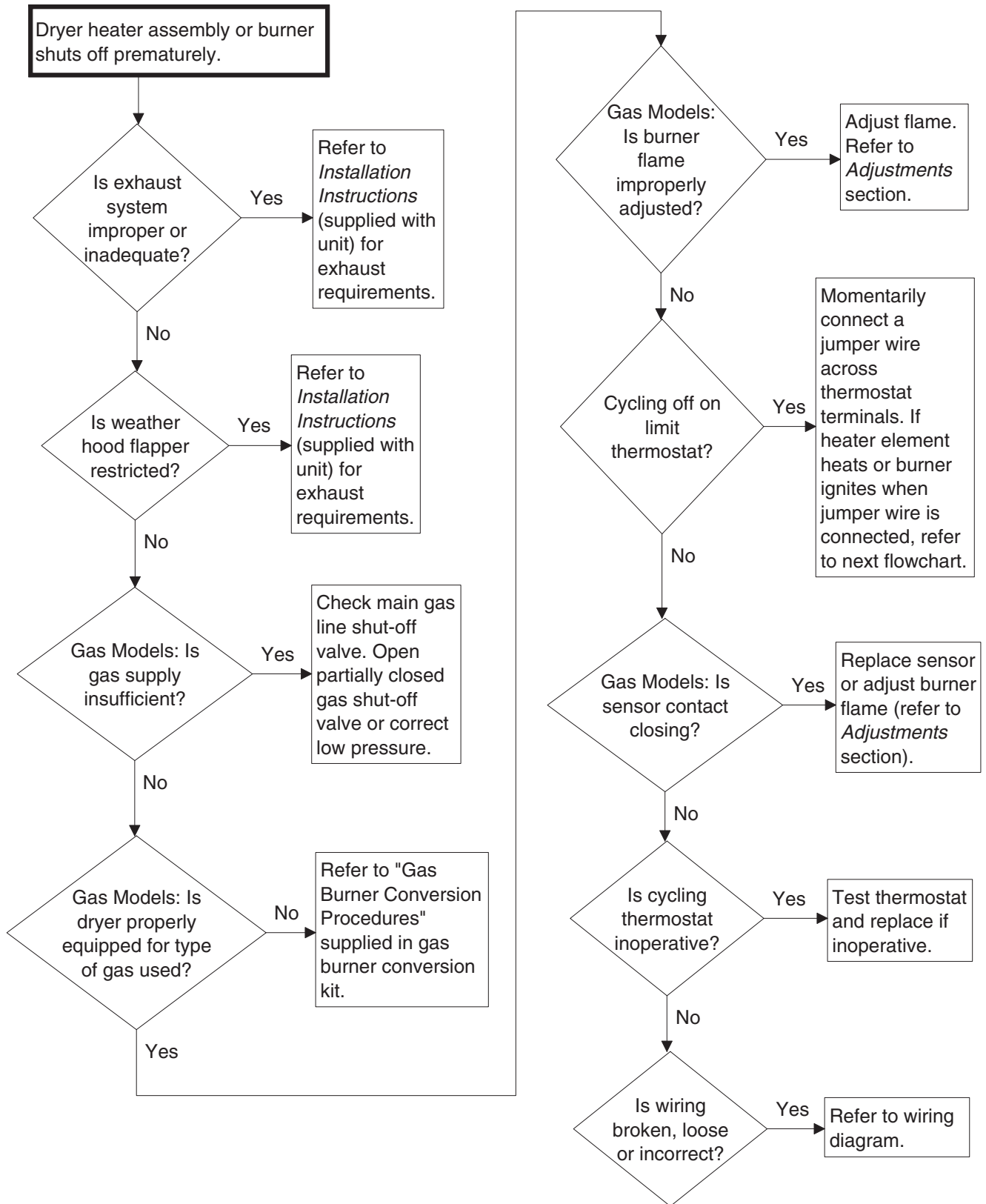

SWD1698S

17. Dryer Heater Assembly or Burner Repeatedly Cycles Off On Limit Thermostat

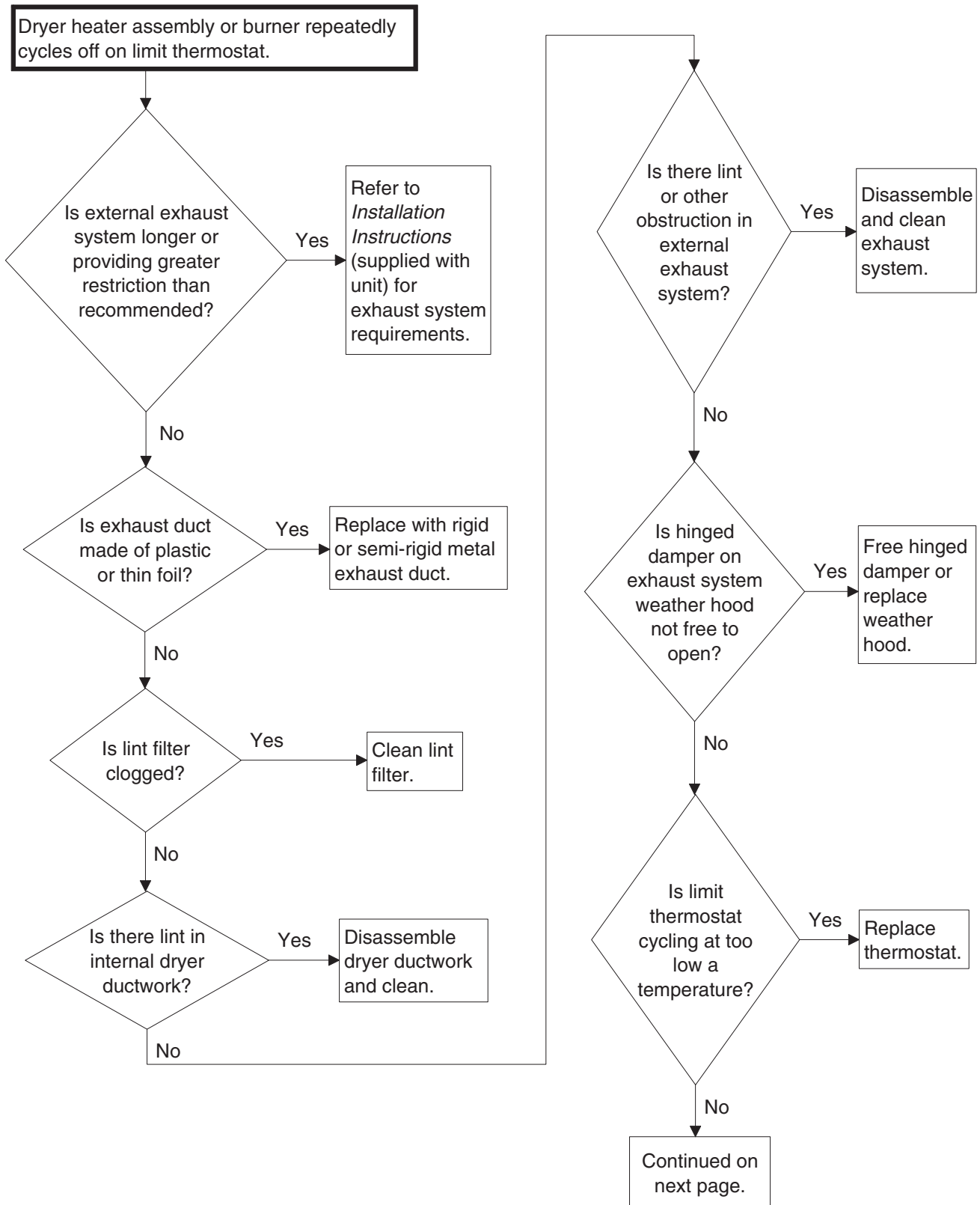

SWD1699S-a

17. Dryer Heater Assembly or Burner Repeatedly Cycles Off On Limit Thermostat (continued)

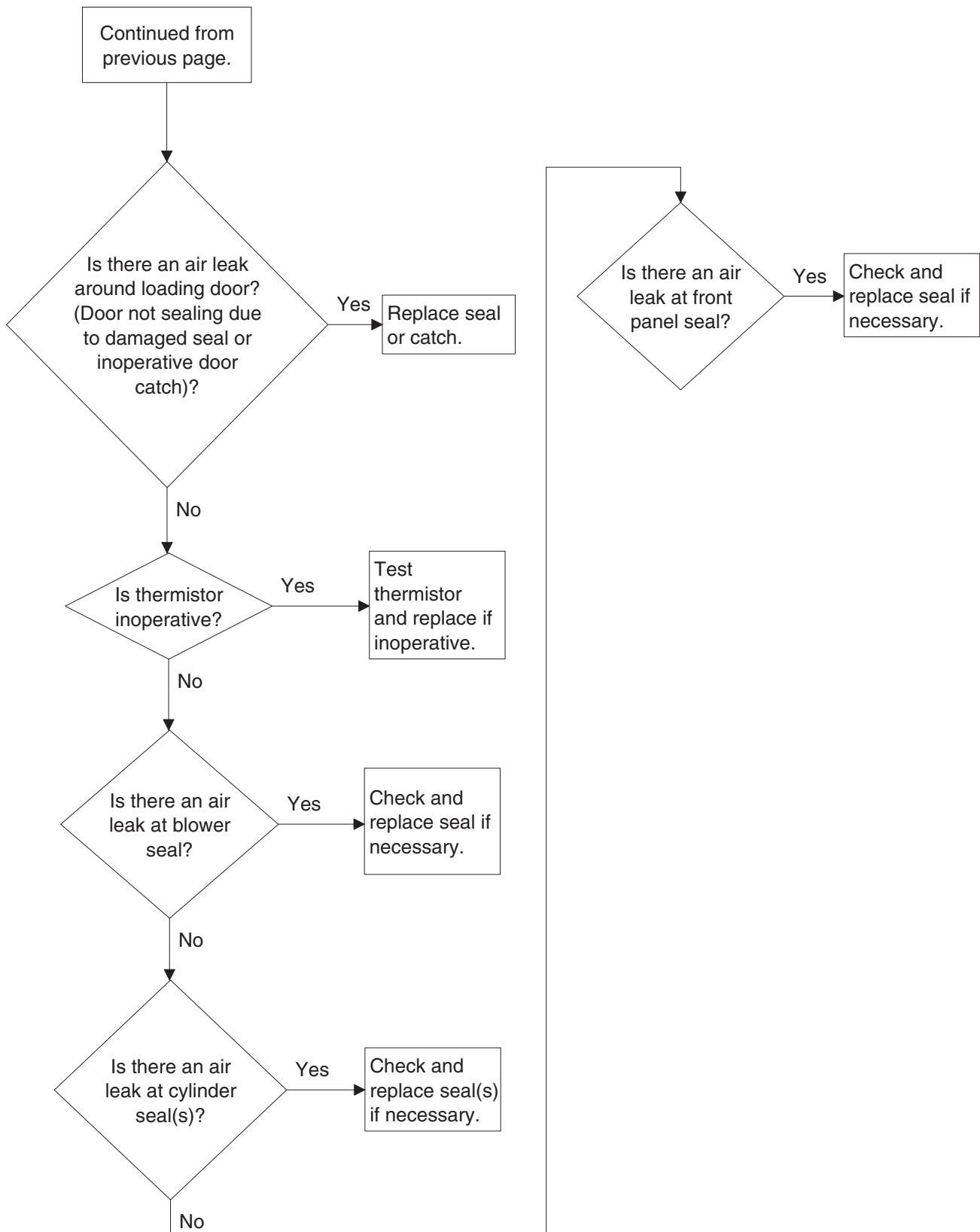

SWD1699S-b

18. Dryer Heater Assembly or Burner Does Not Shut Off

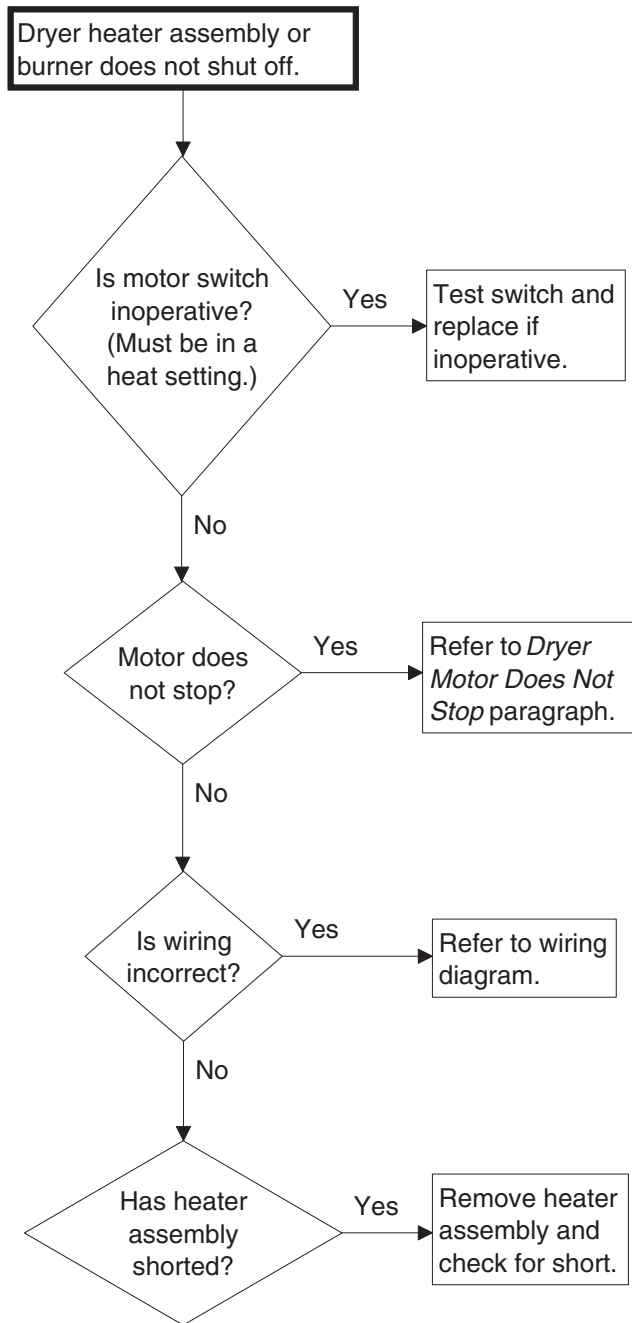

SWD1700S

19. Clothes Do Not Dry in Dryer

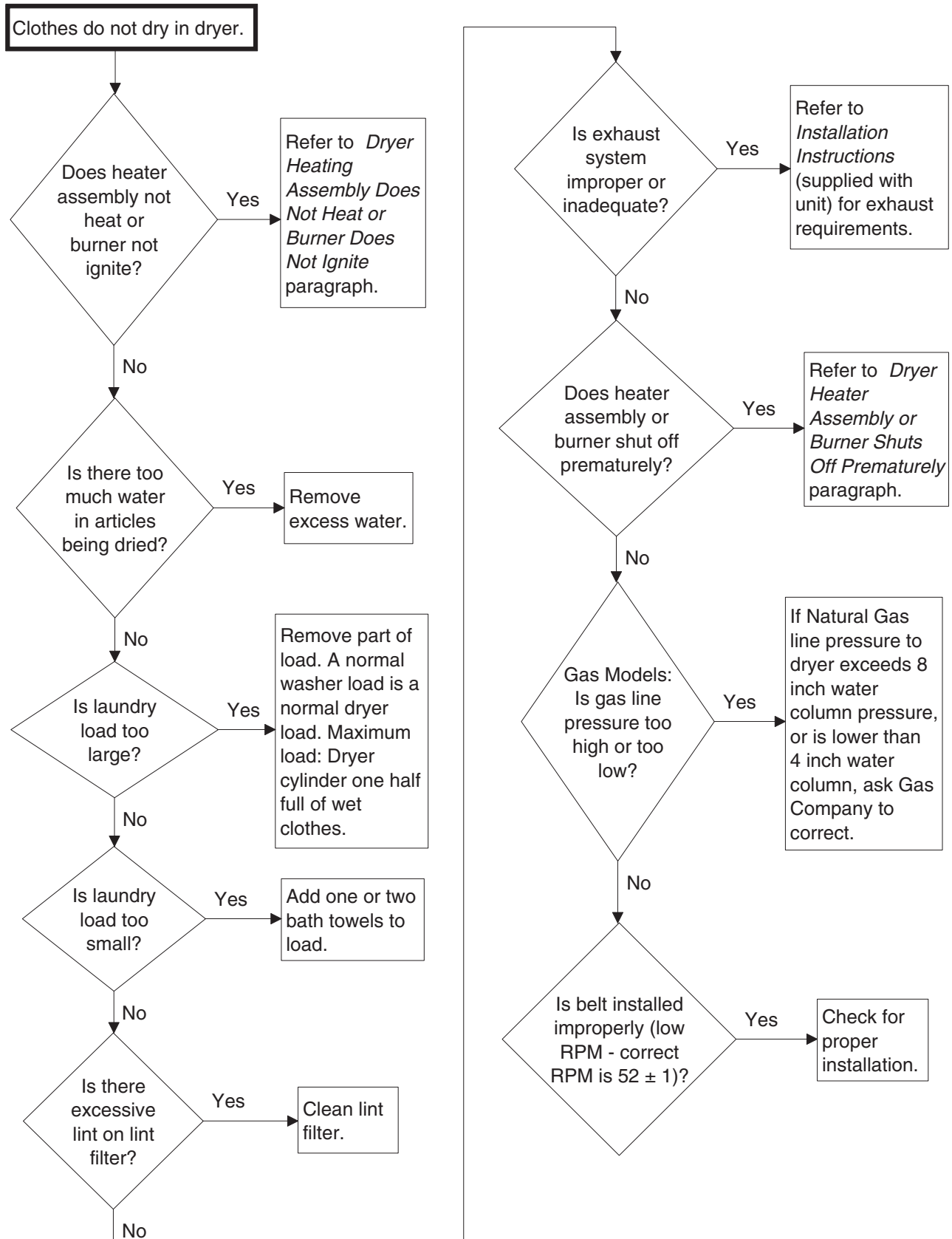

SWD1701S

Dryer Troubleshooting

20. Clothes Are Too Hot When Removed From Dryer

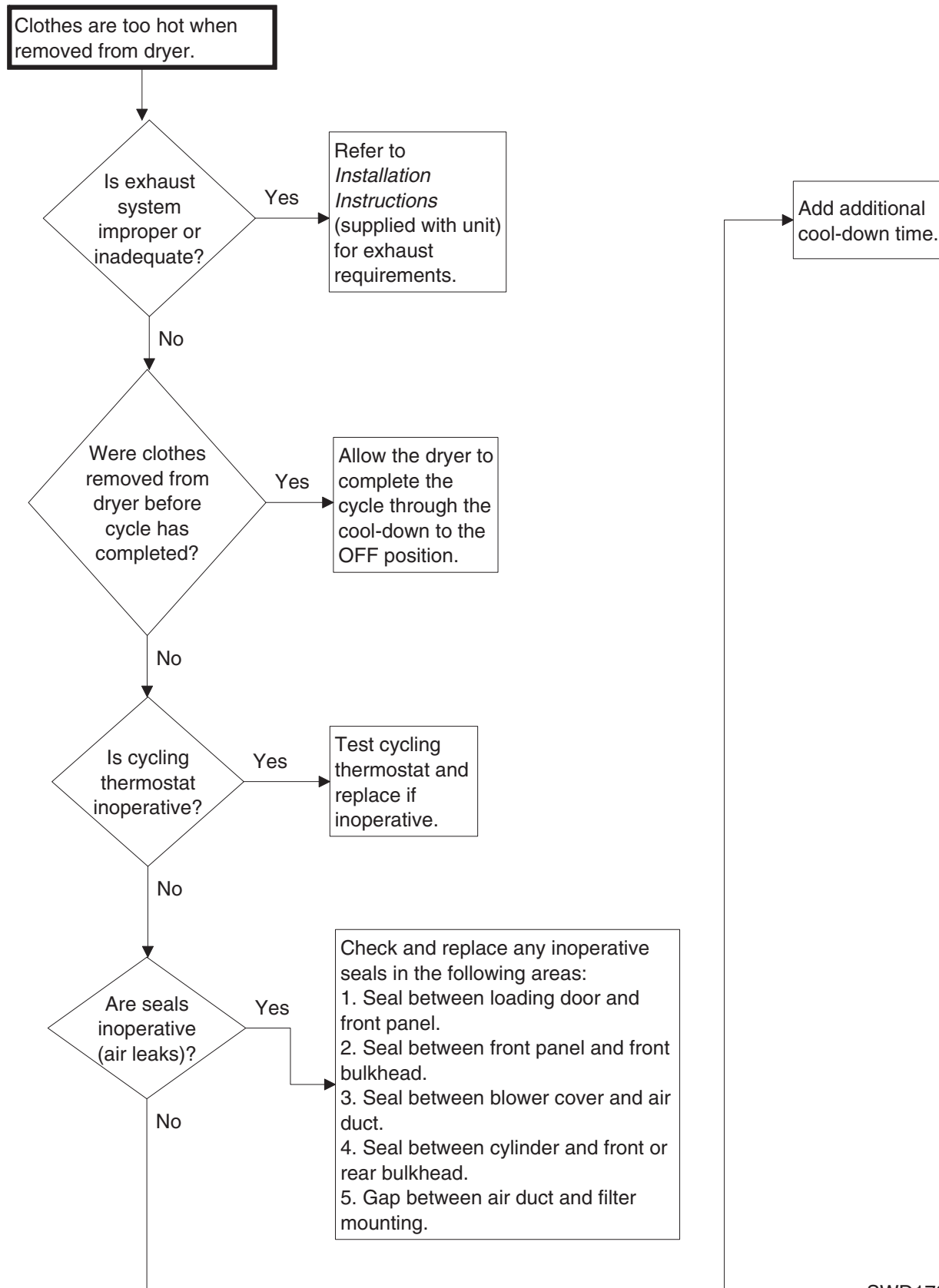

SWD1702S

21. Excessive Chattering Or Vibrating Noise in Dryer

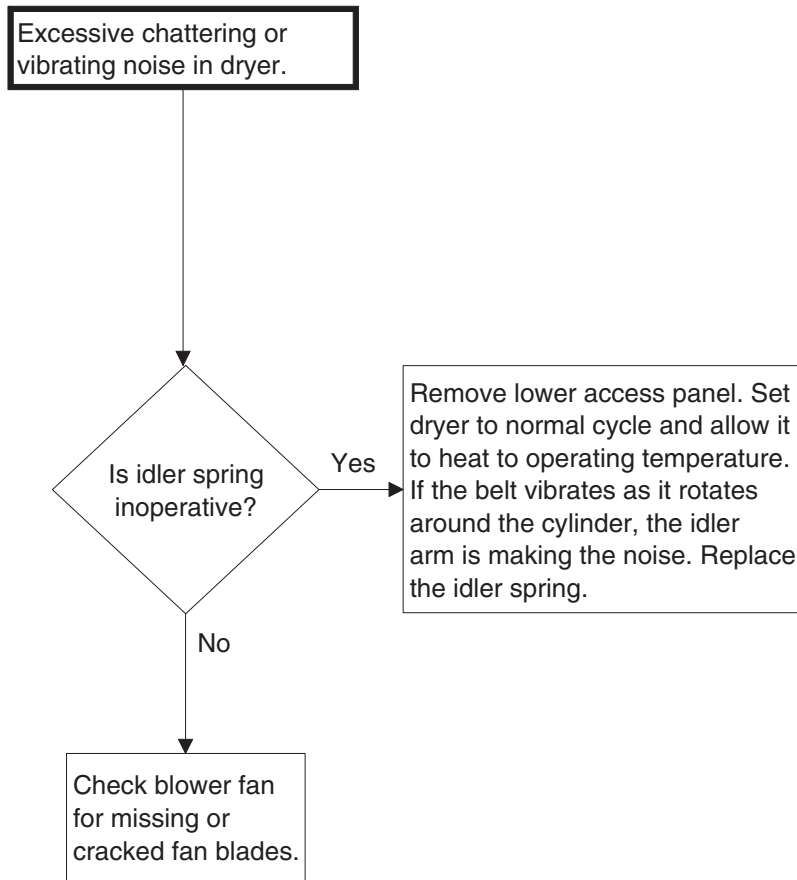

SWD1703S

Dryer Troubleshooting

22. Excessive Humming Or Whistling Noise in Dryer

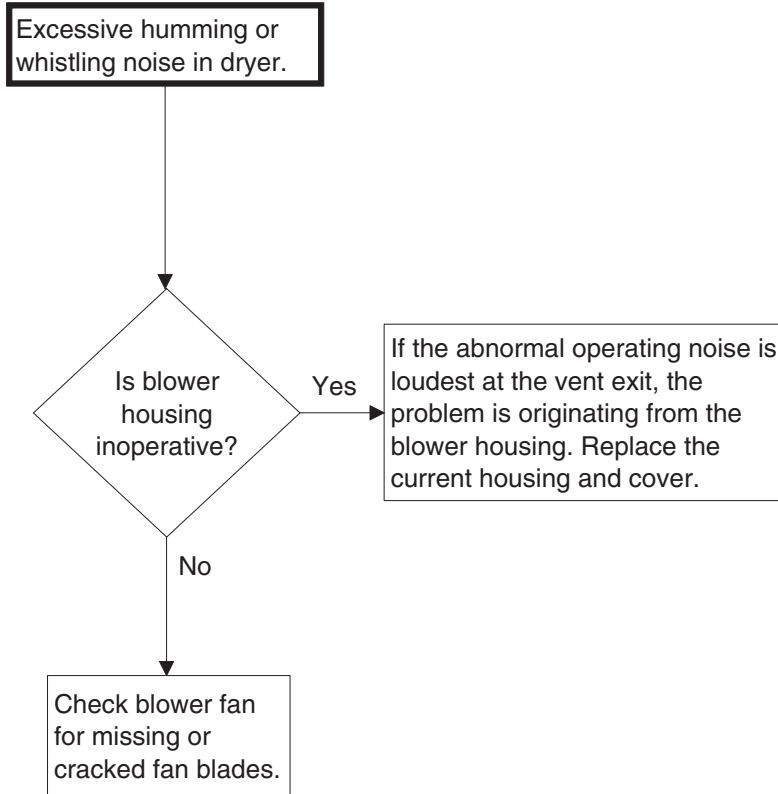

SWD1704S

Section 5

Washer Electronic Control Troubleshooting

	WARNING
<p>To reduce the risk of electric shock, fire, explosion, serious injury or death:</p> <ul style="list-style-type: none"> • Disconnect all electric power to the machine and accessories before servicing. • Close gas shut-off valve to gas dryer before servicing. • Never start machine with any guards/panels removed. • Whenever ground wires are removed during servicing, these ground wires must be reconnected to ensure that the machine is properly grounded. • Washer motor not grounded! Disconnect electric power before servicing motor. 	
W502	

23. Error Code Listing

Following is a list of possible error codes for an electronic control. Errors beginning with “EI” refer to external device Infra-red communication errors. Errors

beginning with “EC” refer to card reader errors. All other errors refer to machine errors.

Display	Description	Cause/ Corrective Action
EI01	Transmission Failure	Communication failure. Re-aim external device and try again.
EI02	Time-out Error	Communication failure. Re-aim external device and try again.
EI03	Invalid Command Code	Communication successful, but the command was not valid for this machine type, or the control could not perform the command in its current mode of operation. Ensure data is for current machine type and control is in correct mode.
EI04	Expecting Upload Request	Communication failure. Re-aim external device and try again.
EI05	Invalid or Out-of-Range Data	The value in at least one of the programming options is invalid or out of range. Recheck the programming option’s value and try again.
EI09	CRC-16 Error	Communication failure. Re-aim external device and try again.
EI0A	Framing Error	Communication error. Re-aim external device and try again.
EI0C	Time-out Exceeded	Communication error. Re-aim external device and try again.
EI0E	Encryption Error	Communication error. Re-aim external device and try again. If the problem persists, check that the security code is correct.

Table 3

Washer Electronic Control Troubleshooting

Display	Description	Cause/ Corrective Action
EI0F	Infra-red Disabled	Communication failure or infra-red is disabled. Manually enable infra-red on control or re-aim external device and try again.
EC02	Time-out Error	Communication failure. Try card again.
EC03	Invalid Command Code	Communication successful, but the command was not valid for this machine type, or the control could not perform the command in its current mode of operation. Ensure data is for current machine type and control is in correct mode.
EC05	Invalid or Out-of-Range Data	The value in at least one of the programming options is invalid or out of range. Recheck the programming option's value and try again.
EC11	No Card Reader Initialization	Communication is valid, but there is no card reader initialization. Power down, power up and try again.
EC18	No Communication	Card reader is initialized, communication lost. Power down, power up and try again. If error persists, replace control or card reader.
EC19	No Card Reader Communication	Communication failure. Power down, power up and try again. If error persists, replace control or card reader.
Right most decimal point Lit	Network Communication Error	Communication problem. Wait for 1.5 minutes for error to clear. If error doesn't clear, power-down and power-up the machine. If error persists, replace control or network board.
ALrn	Break-in Alarm Error	Service the door or coin vault switches.
oFF	Break-in Alarm Shutdown Error	Service the door or coin vault switches.
E FL	Fill Error	Pressure switch fails to open in 30 minutes (or other programmed length of time) in any fill agitate cycle.
E SP	SPI Communications Error	Master control cannot communicate with motor control. Caused by transformer unplugged or wiring to motor control incorrect. Power down the machine, power up and try again.
E dL	Door Lock Error	Door does not lock within 15 seconds of closing (open and reclose door) or doesn't unlock 3 minutes after cycle completion.
E do	Door Opened During A Running Cycle	Control detects door open and door locked inputs high. Caused by pulling on door while locked or about to lock. Correct inoperative door locking system.
E Ub	Unbalance Error	Unable to balance load. Redistribute load and run cycle.
E dF	Drive Failure	Motor unplugged, motor failure, tachometer circuit open or drum locked up. Unpower machine to reset.
door	Door Open Indicator	Door is not closed during an active cycle. If door is closed, check for improper wiring or faulty door switch.

Table 3

Washer Electronic Control Troubleshooting

Display	Description	Cause/ Corrective Action
E rr	Coin Error	Invalid coin pulse or inoperative coin sensor. Check coin drop area and remove obstructions. If error persists, tampering may have occurred. Evaluate security procedures.
E oP (models equipped with heater)	Open Thermistor Error	Thermistor circuit opens while heating. Heater will turn off and cycle will continue.
E SH (models equipped with heater)	Shorted Thermistor Error	Thermistor circuit is shorted while heating. Heater will turn off and cycle will continue.
E Ht (models equipped with heater)	Heater Error	Programmed temperature hasn't been reached in more than two hours. Cycle will continue with heater off.

Table 3

24. PDA Does Not Communicate With Control

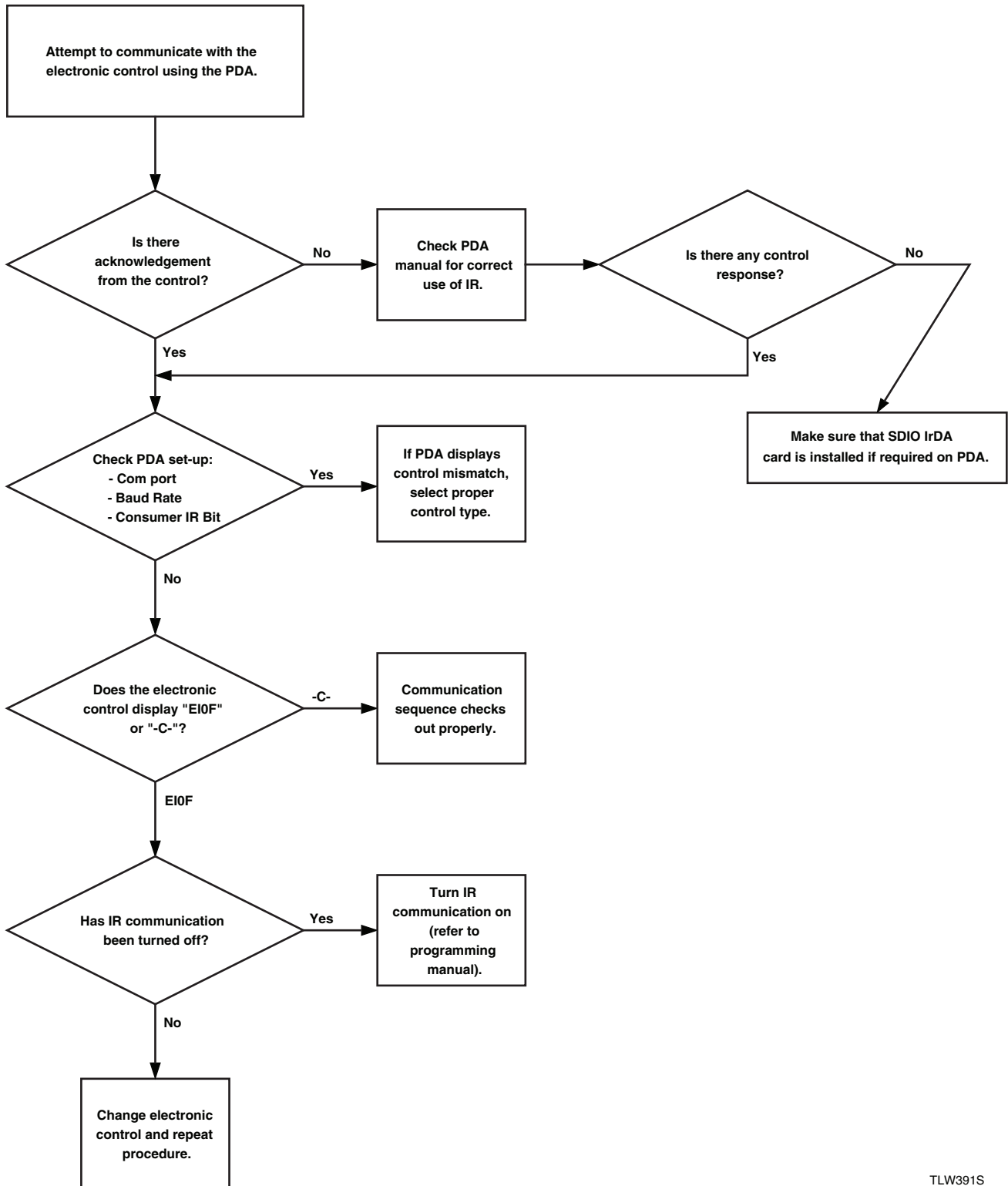

TLW391S

25. Coins Ignored When Entered

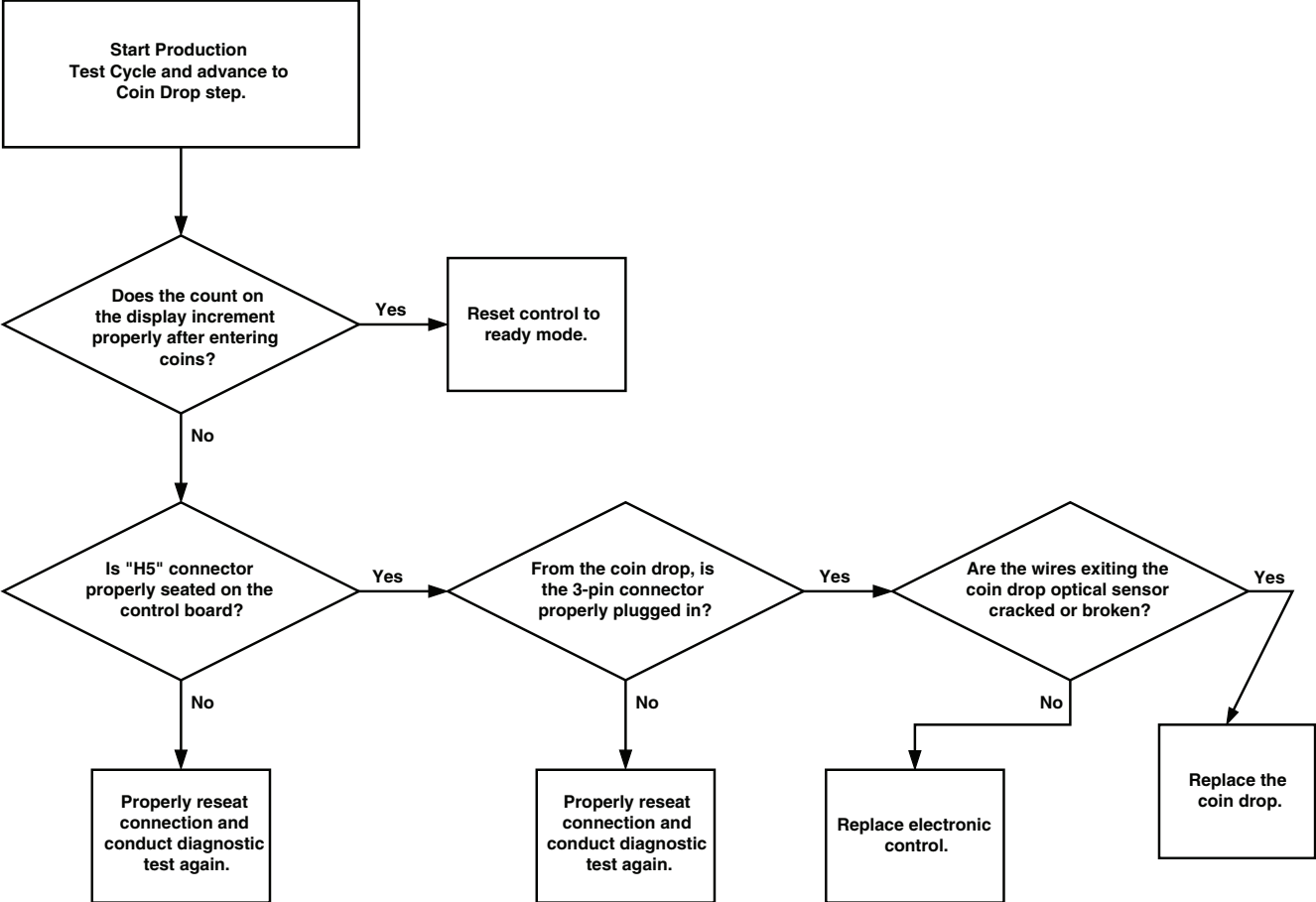

FLW1781S

26. No Visible Display on Control

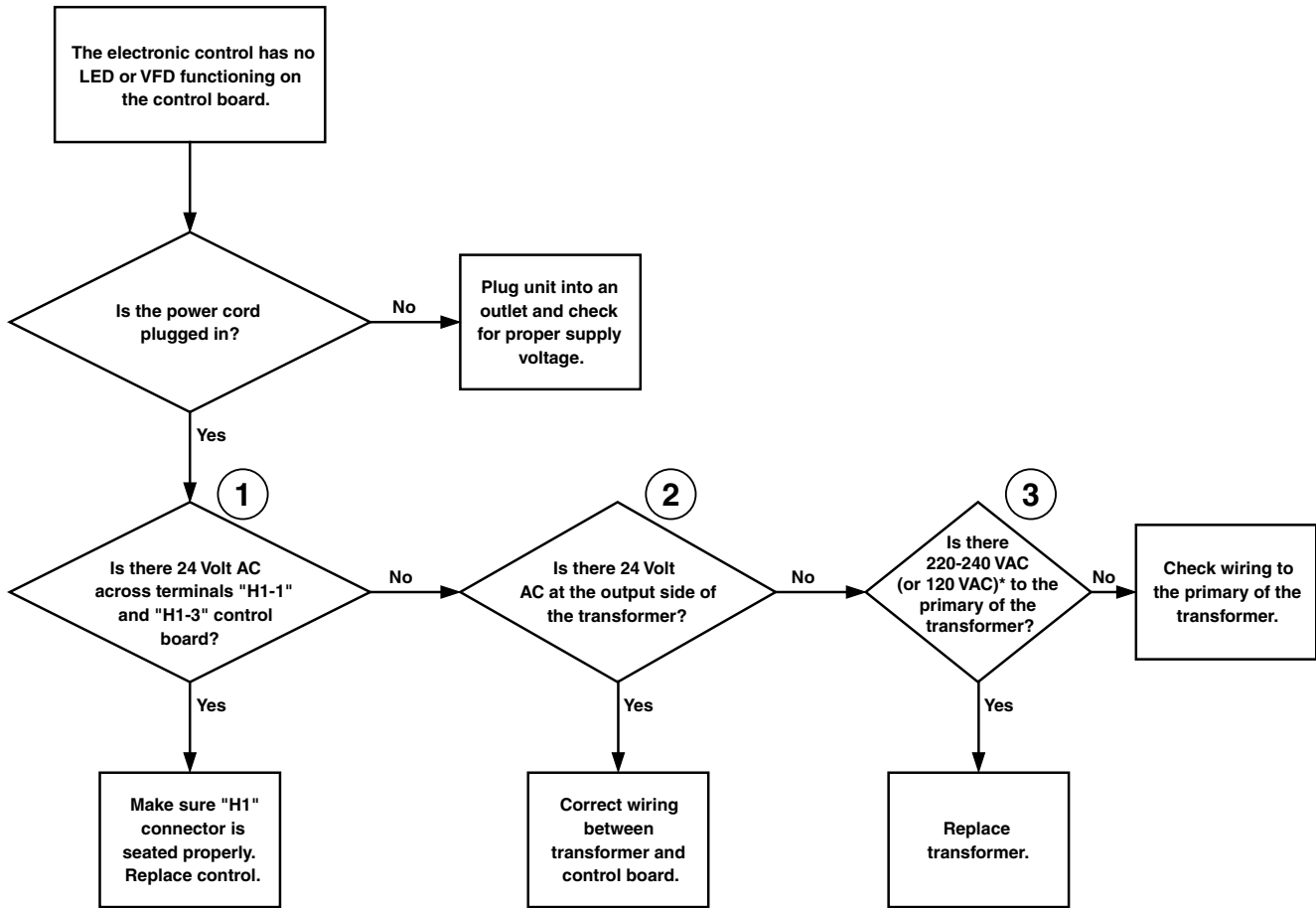

*Refer to machine serial plate for correct voltage.

FLW1695S

No Visible Display on Control

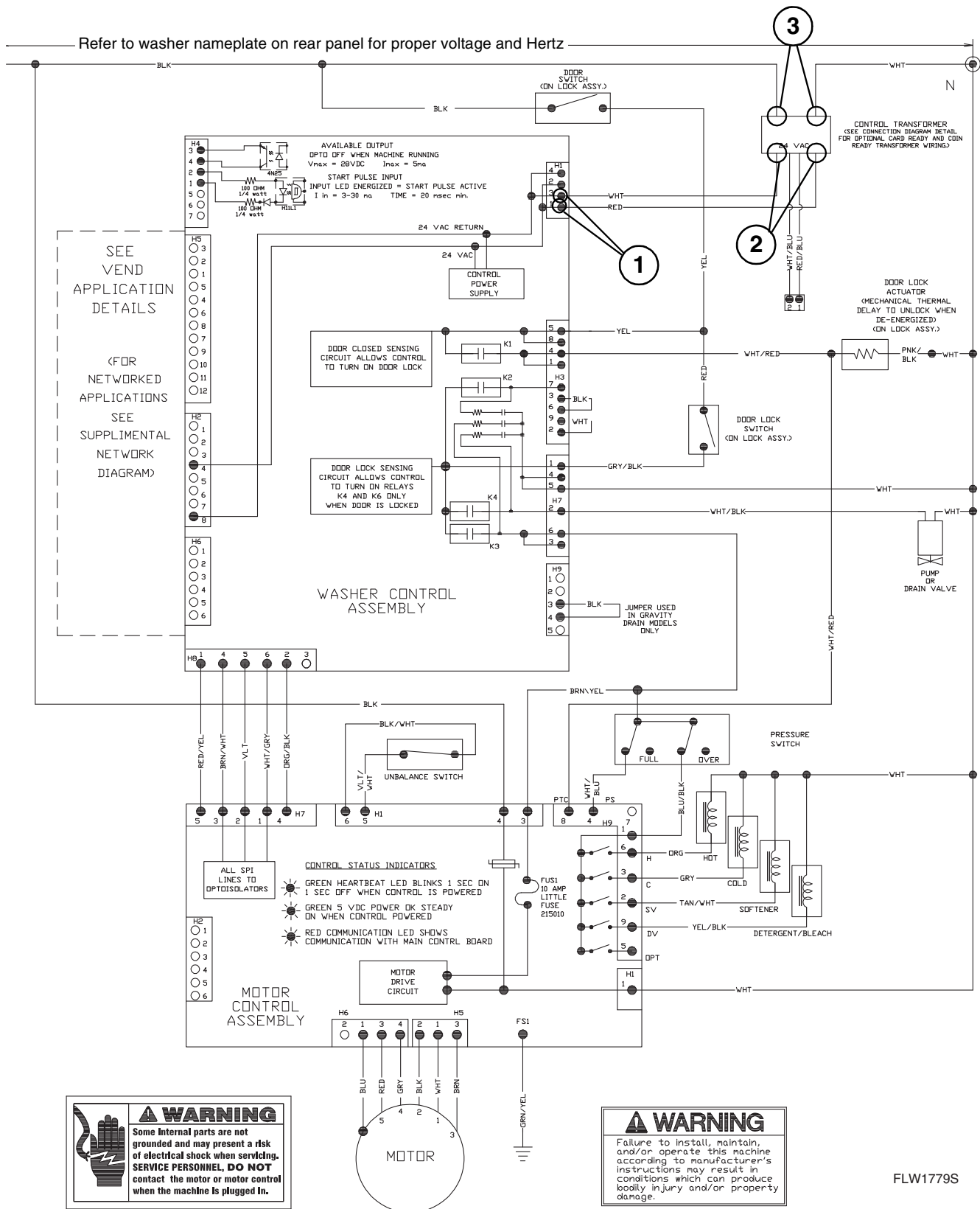

27. Washer Will Not Start – “door” Displayed

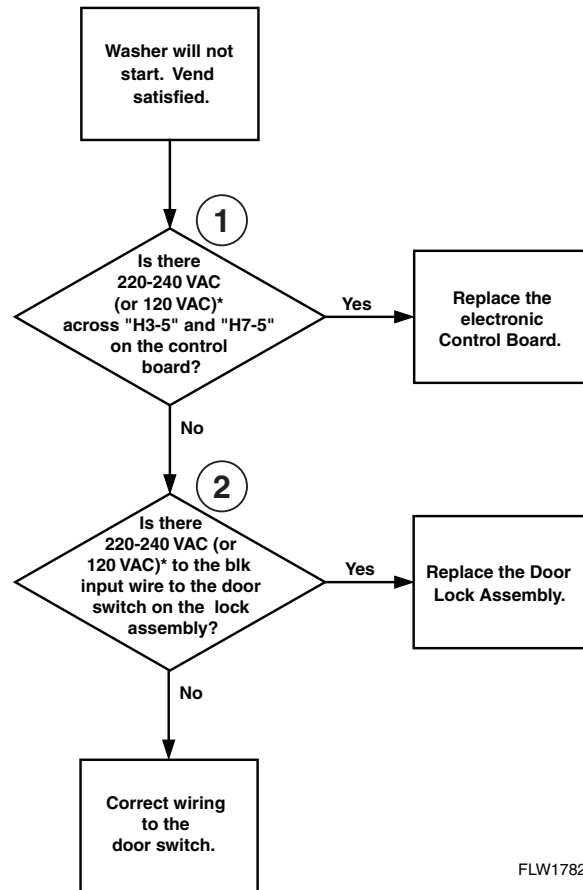

FLW1782S

*Refer to machine serial plate for correct voltage.

Washer Will Not Start – “door” Displayed

Refer to washer nameplate on rear panel for proper voltage and Hertz

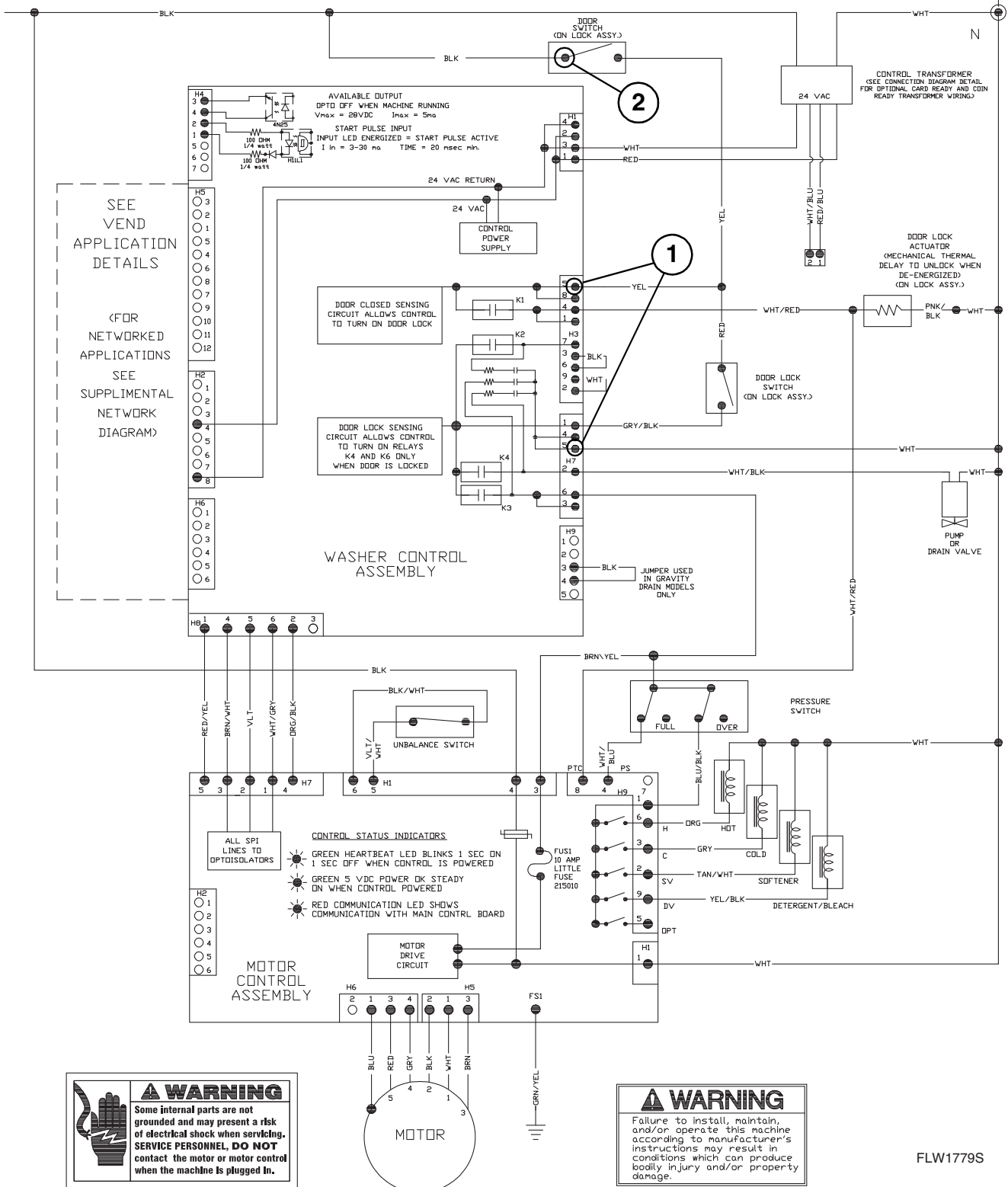

28. Washer Will Not Start – “E dL” on Display

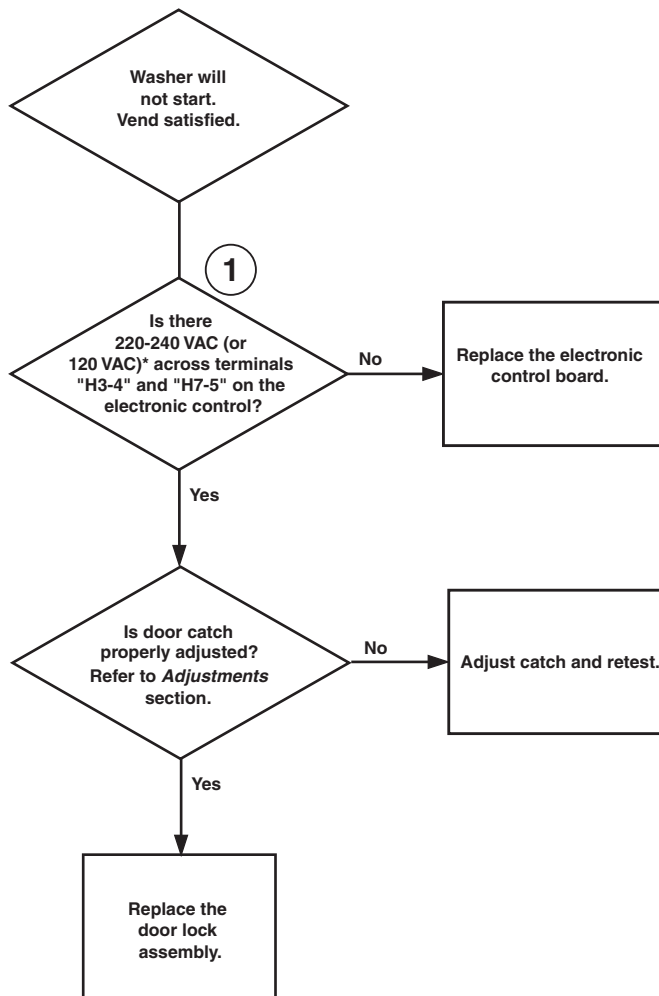

*Refer to machine serial plate for correct voltage.

FLW1783S

Washer Will Not Start – “E dL” on Display

Refer to washer nameplate on rear panel for proper voltage and Hertz

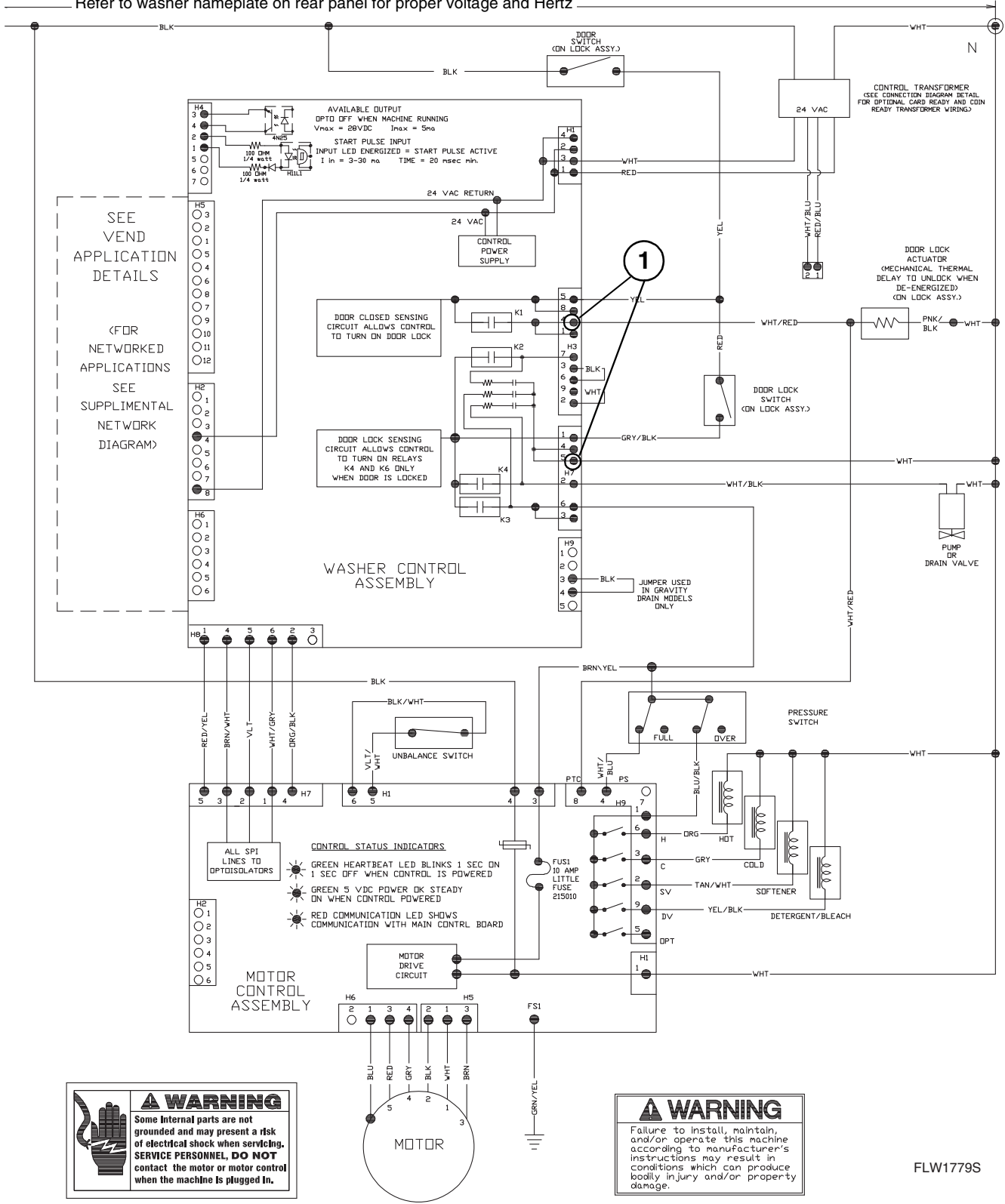

WARNING
 Some internal parts are not grounded and may present a risk of electrical shock when servicing. SERVICE PERSONNEL, DO NOT contact the motor or motor control when the machine is plugged in.

WARNING
 Failure to install, maintain, and/or operate this machine according to manufacturer's instructions may result in conditions which can produce bodily injury and/or property damage.

FLW1779S

29. Washer Will Not Fill (Machine Empty, No “E SP” on Display)

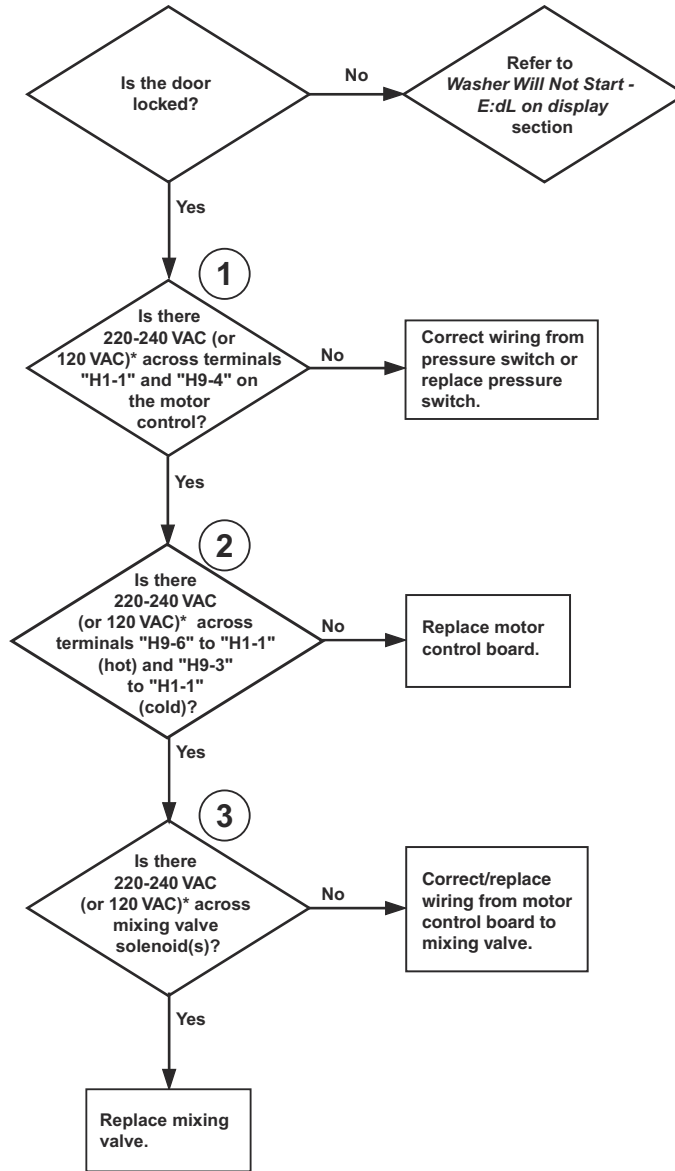

*Refer to machine serial plate for correct voltage.

FLW1787S

Washer Will Not Fill (Machine empty, No "E SP" on Display)

Refer to washer nameplate on rear panel for proper voltage and Hertz

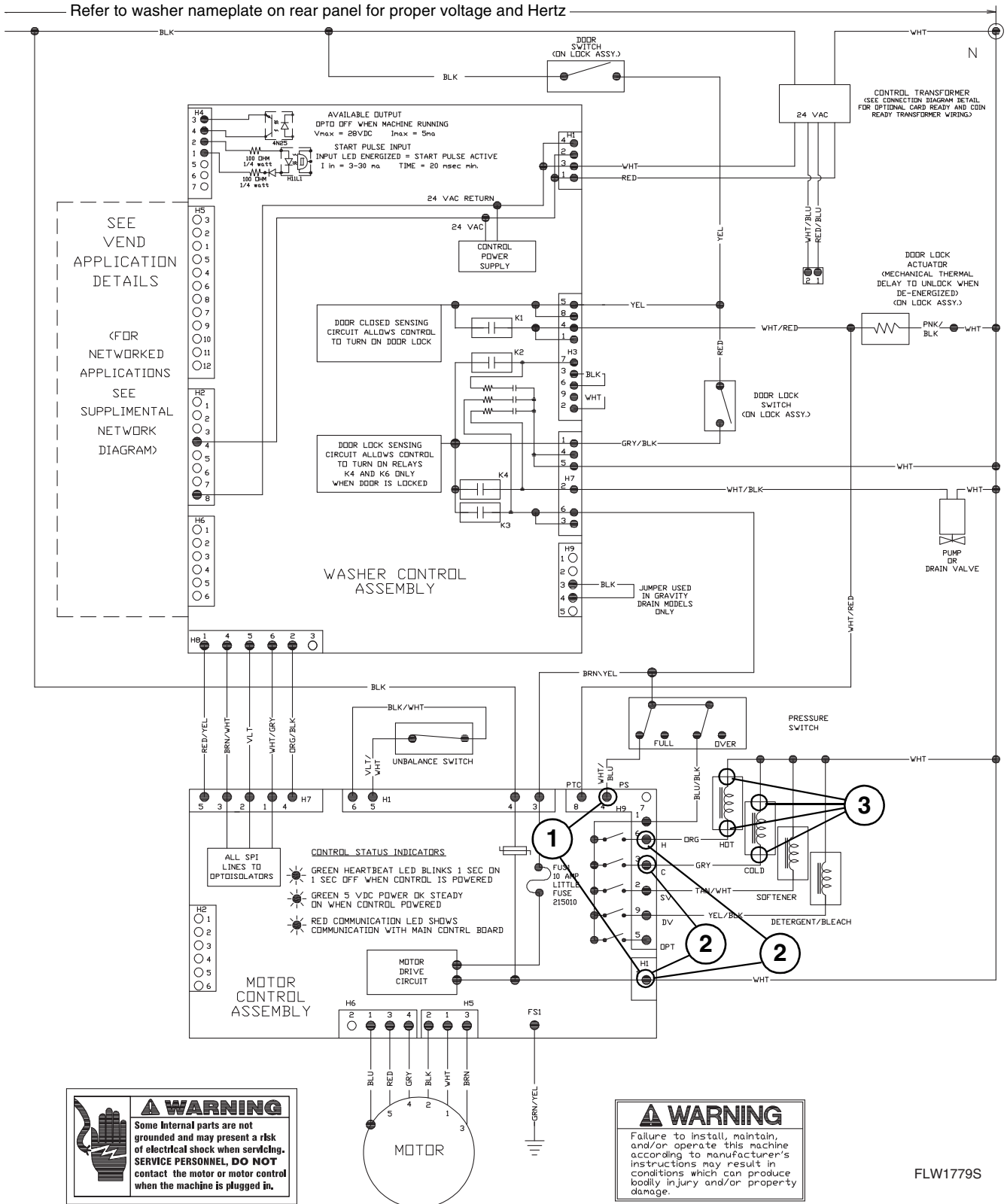

FLW1779S

30. Washer Overflows

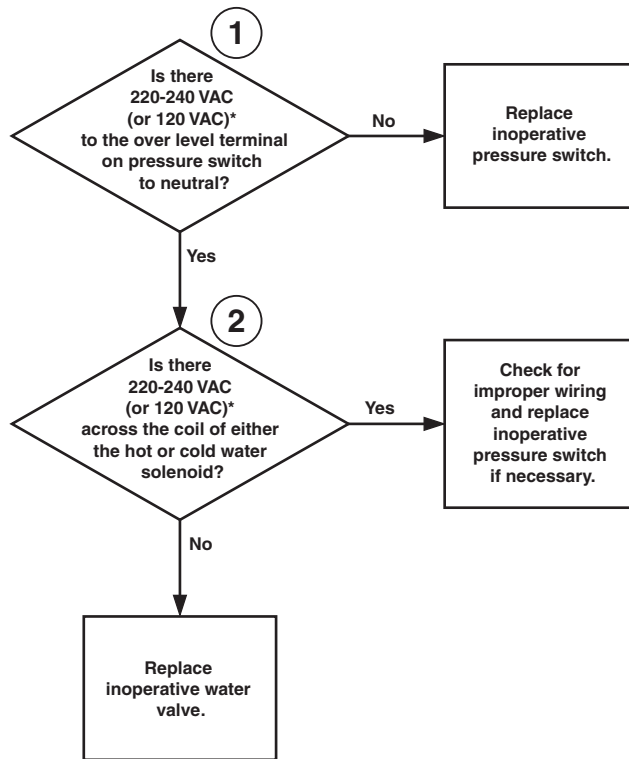

*Refer to machine serial plate for correct voltage.

FLW1699S

Washer Overflows

Refer to washer nameplate on rear panel for proper voltage and Hertz

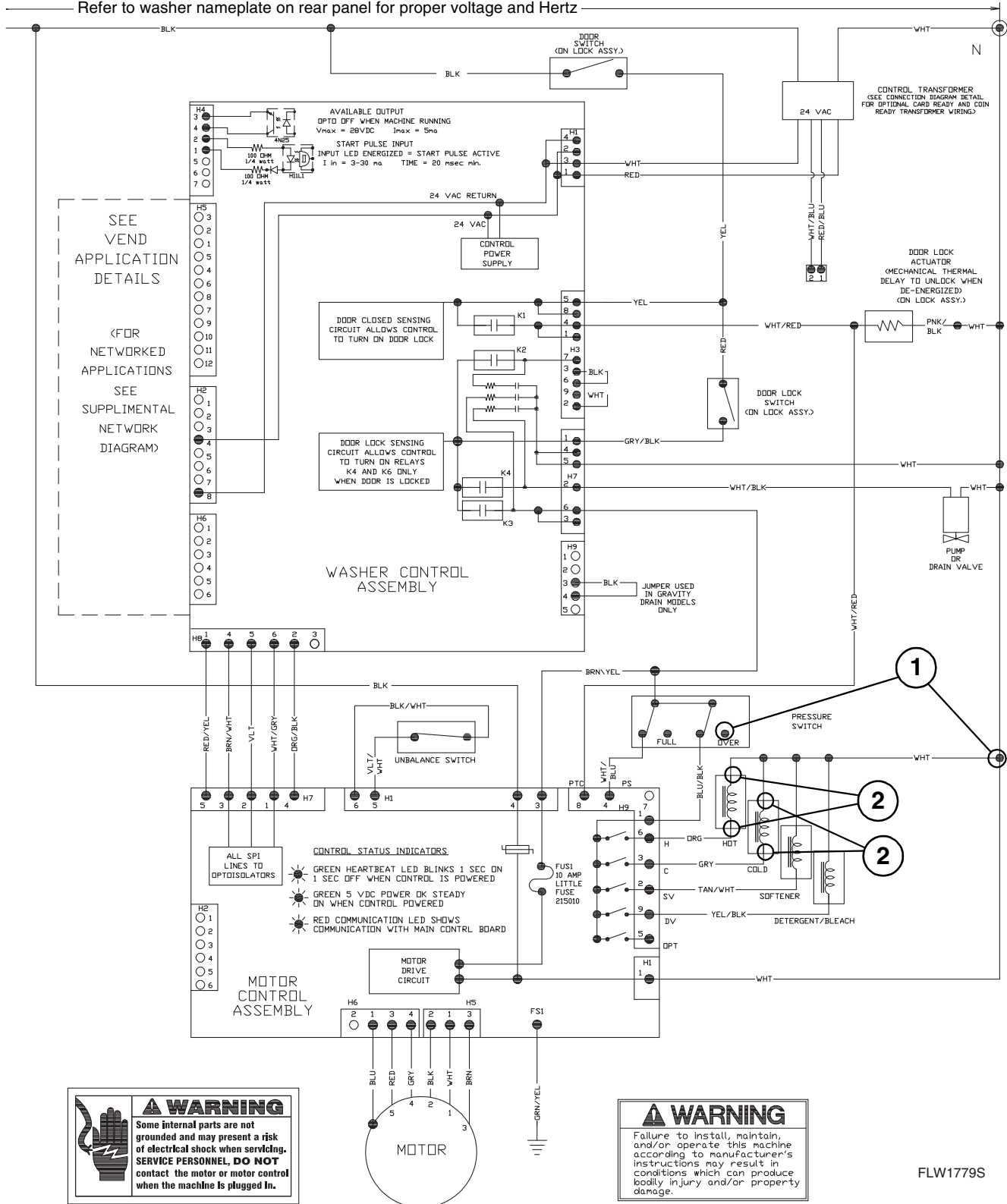

31. Pump or Drain Valve Does Not Operate

NOTE: Check at beginning of spin/drain portion of cycle.

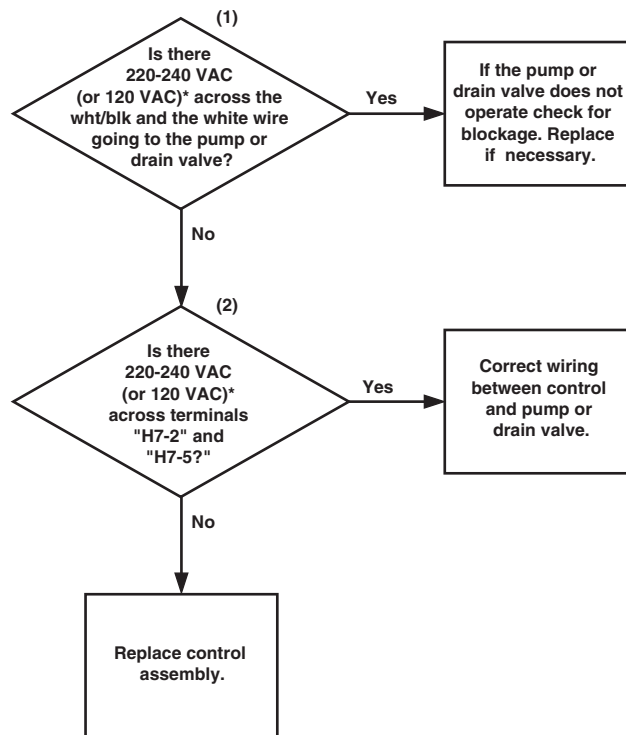

*Refer to machine serial plate for correct voltage.

FLW1784S

Pump or Drain Valve Does Not Operate

Refer to washer nameplate on rear panel for proper voltage and Hertz

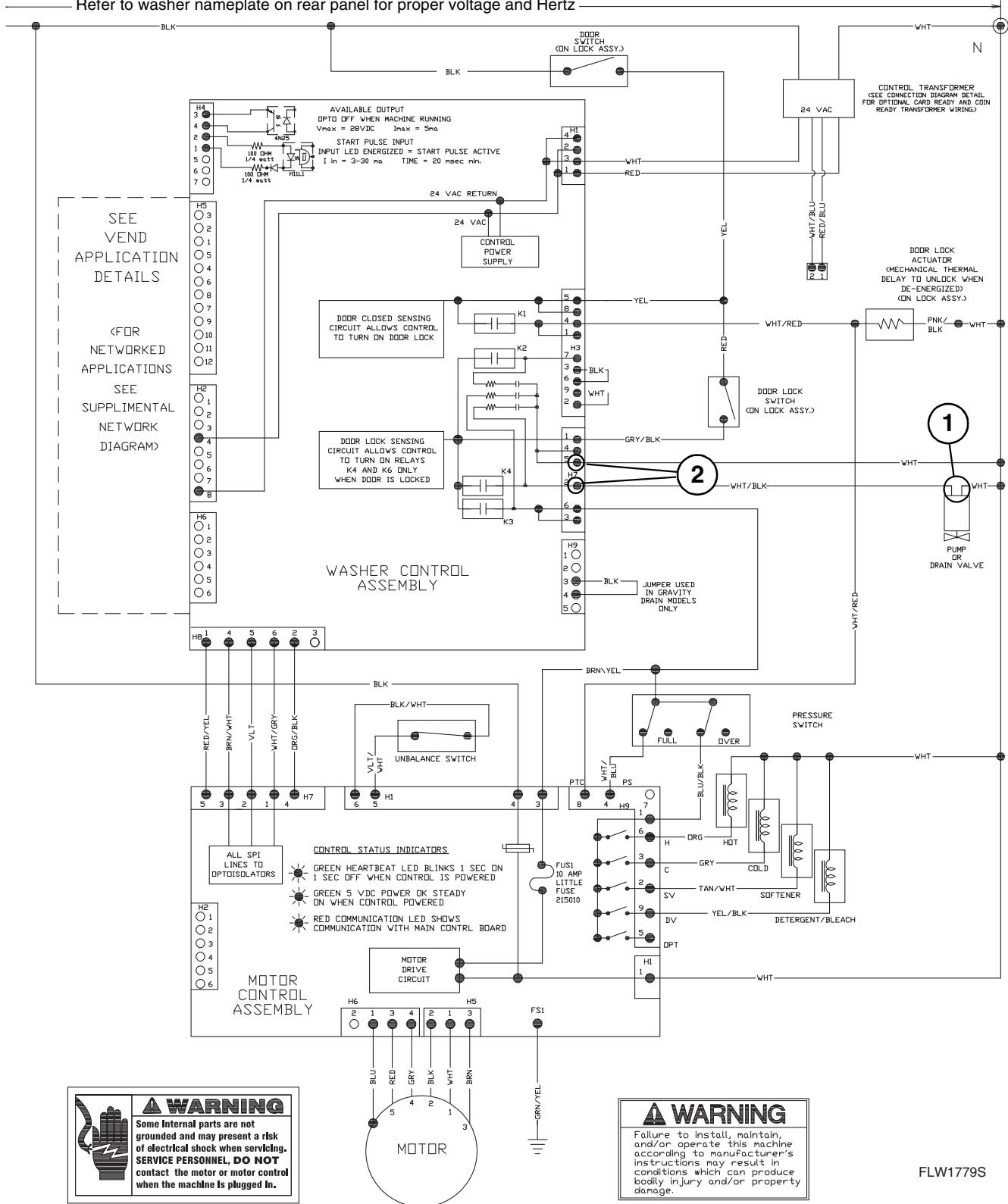

FLW1779S

32. Serial Communication Error (“E SP” on Display)

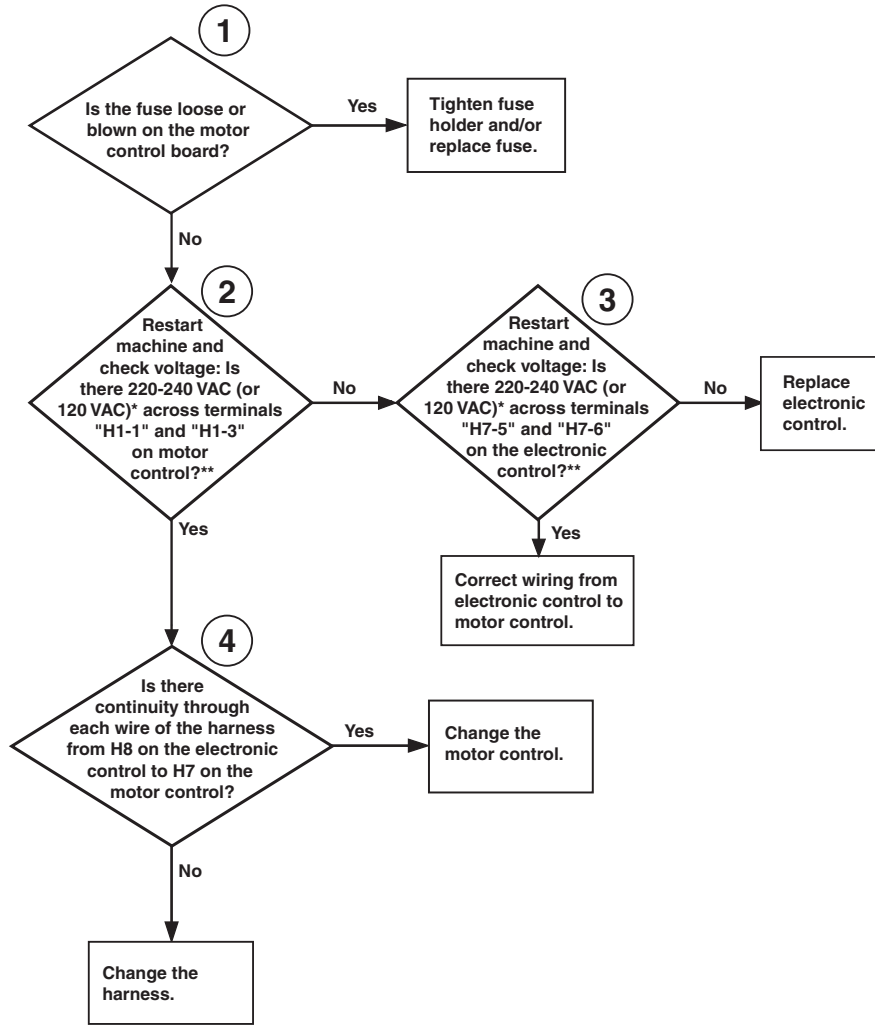

*Refer to machine serial plate for correct voltage.

**NOTE: Machine must be restarted to check voltage. Voltage will be intermittently present during first 15 seconds until E SP is displayed.

FLW1785S

Serial Communication Error ("E SP" on Display)

Refer to washer nameplate on rear panel for proper voltage and Hertz

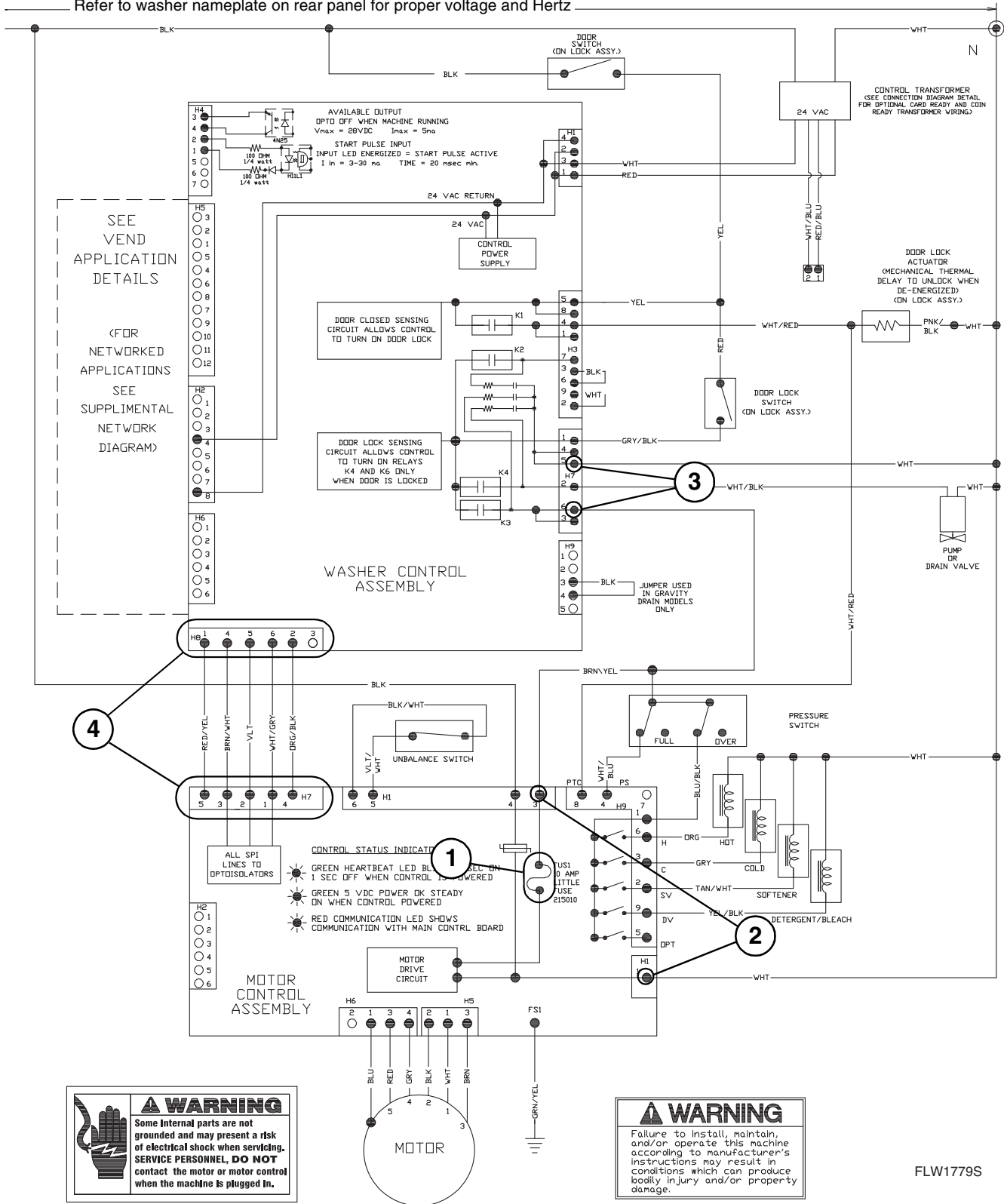

FLW1779S

33. Motor Does Not Run (“E dF” on Display)

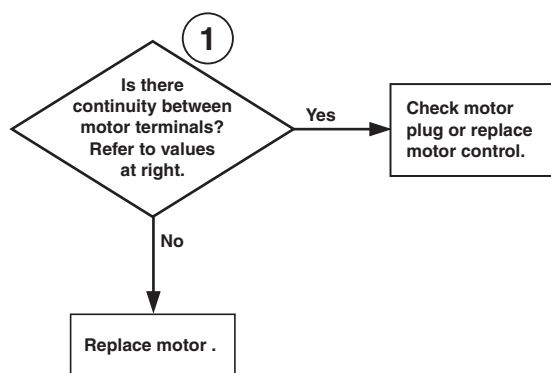

Motor Resistance Values:
Tach. Circuit: Approx. 115 ohms (Terminals 4-5)
Windings: Approx. 4 - 5 ohms (Terminals 1-2, 1-3, 2-3)

FLW1702S

Motor Does Not Run (“E dF” on Display)

Refer to washer nameplate on rear panel for proper voltage and Hertz

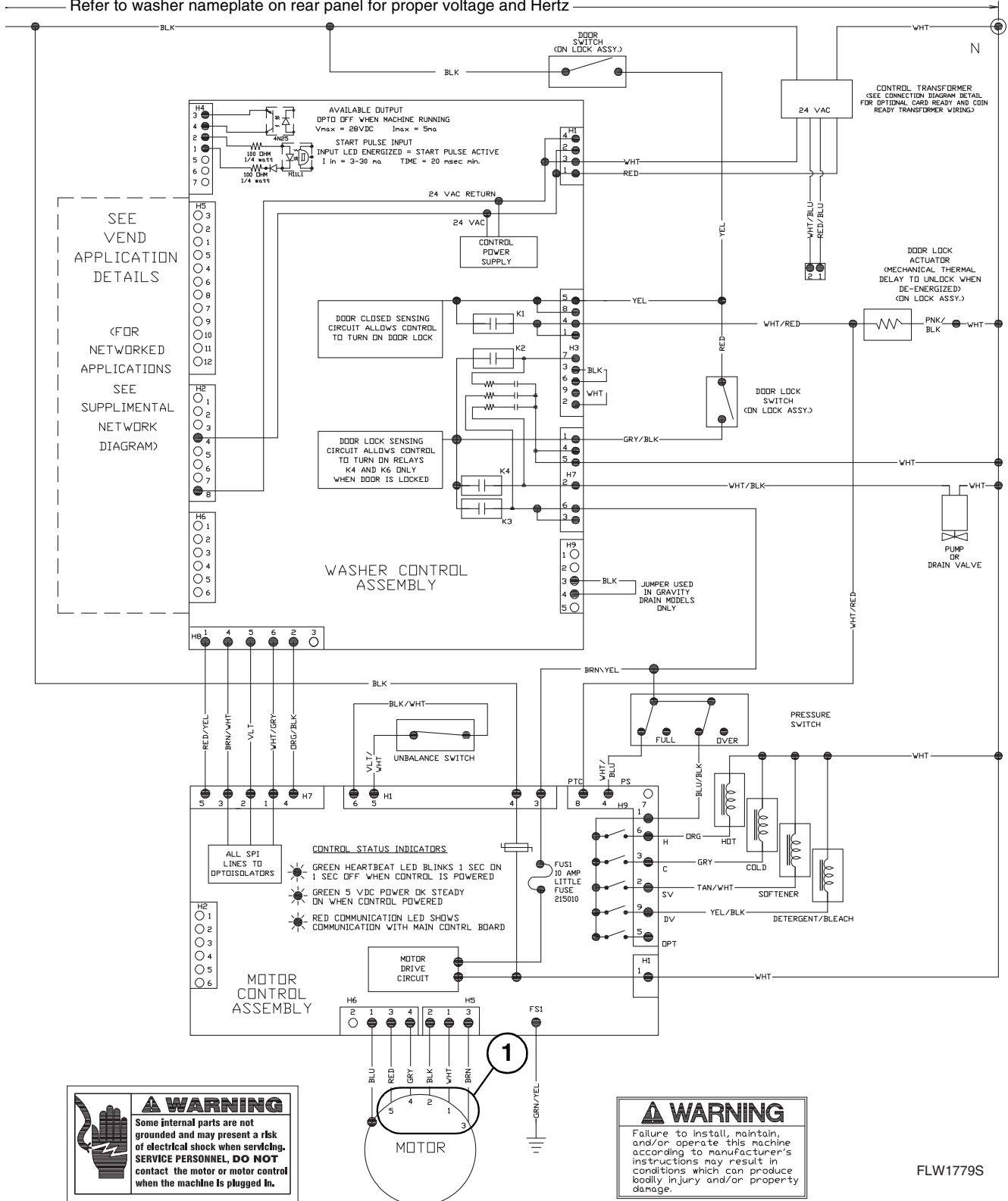

FLW1779S

34. Washer Will Not Heat (Models Equipped with Heater) (“E oP” or “E SH” Displayed)

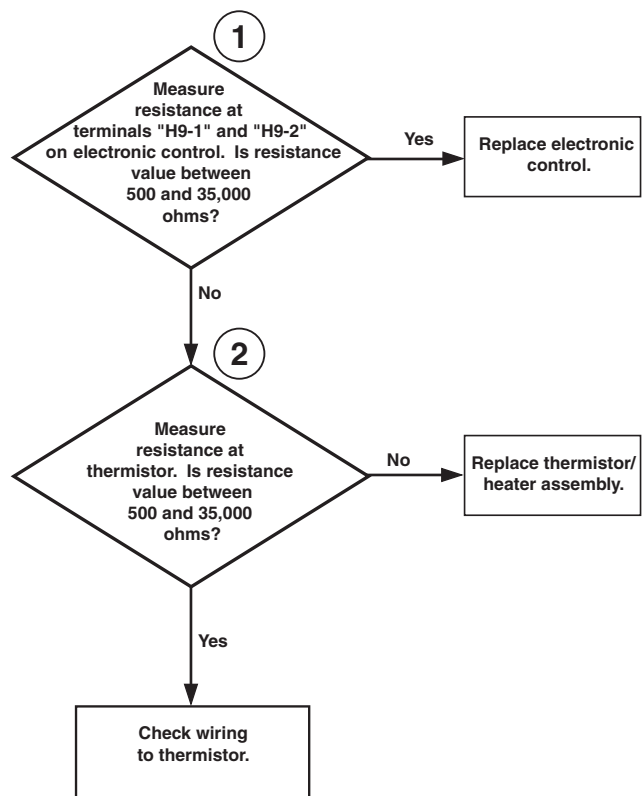

FLW1786S

35. Washer Will Not Heat (Models Equipped with Heater) (3 Phase Heater Machines Only)

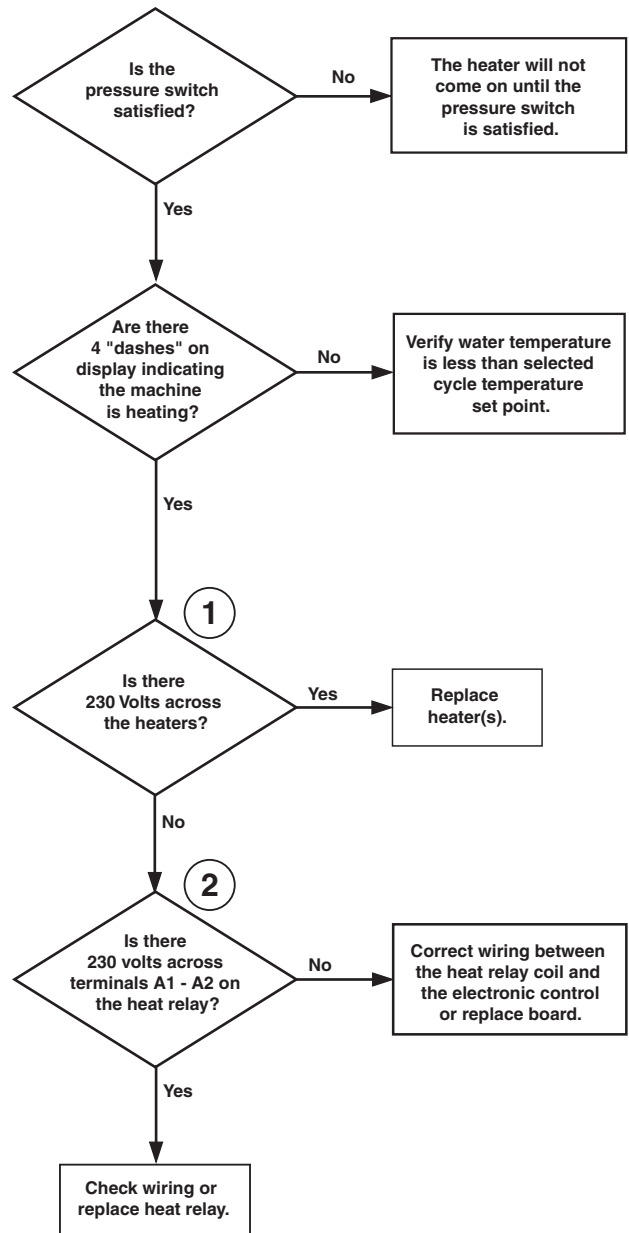

FLW1703S

Section 6

Dryer Electronic Control Troubleshooting



WARNING

To reduce the risk of electric shock, fire, explosion, serious injury or death:

- Disconnect all electric power to the machine and accessories before servicing.
- Close gas shut-off valve to gas dryer before servicing.
- Never start machine with any guards/panels removed.
- Whenever ground wires are removed during servicing, these ground wires must be reconnected to ensure that the machine is properly grounded.
- Washer motor not grounded! Disconnect electric power before servicing motor.

W502

IMPORTANT: Refer to wiring diagram for aid in testing dryer components.

36. Error Codes

Following is a list of possible error codes.

Display Information	Description	Cause/ Corrective Action
Right most DP (decimal point) Lit	Network Communication Error	Communication problem. Wait for 1.5 minutes for error to clear. If error doesn't clear, power-down and power-up the machine. If error persists, replace control or network board.
Alrm	Break-in Alarm Error	Service the door or coin vault switches.
OFF	Break-in Alarm Shutdown Error	Service the door or coin vault switches.
E:OP	Open Temperature Sensor Error	Open temperature sensor circuit wiring. Replace sensor.
E:SH	Shorted Temperature Sensor Error	Short in temperature sensor circuit wiring. Replace sensor.
Err	Coin Error	Invalid coin pulse or inoperative coin sensor. Check coin drop area and remove obstructions. If error persists, tampering may have occurred. Evaluate security procedures.
OP	Open Thermistor	Physical open in the thermistor circuit. Replace thermistor.
SH	Shorted Thermistor	Dead short in the thermistor circuit. Replace thermistor.

37. Coins Ignored When Entered

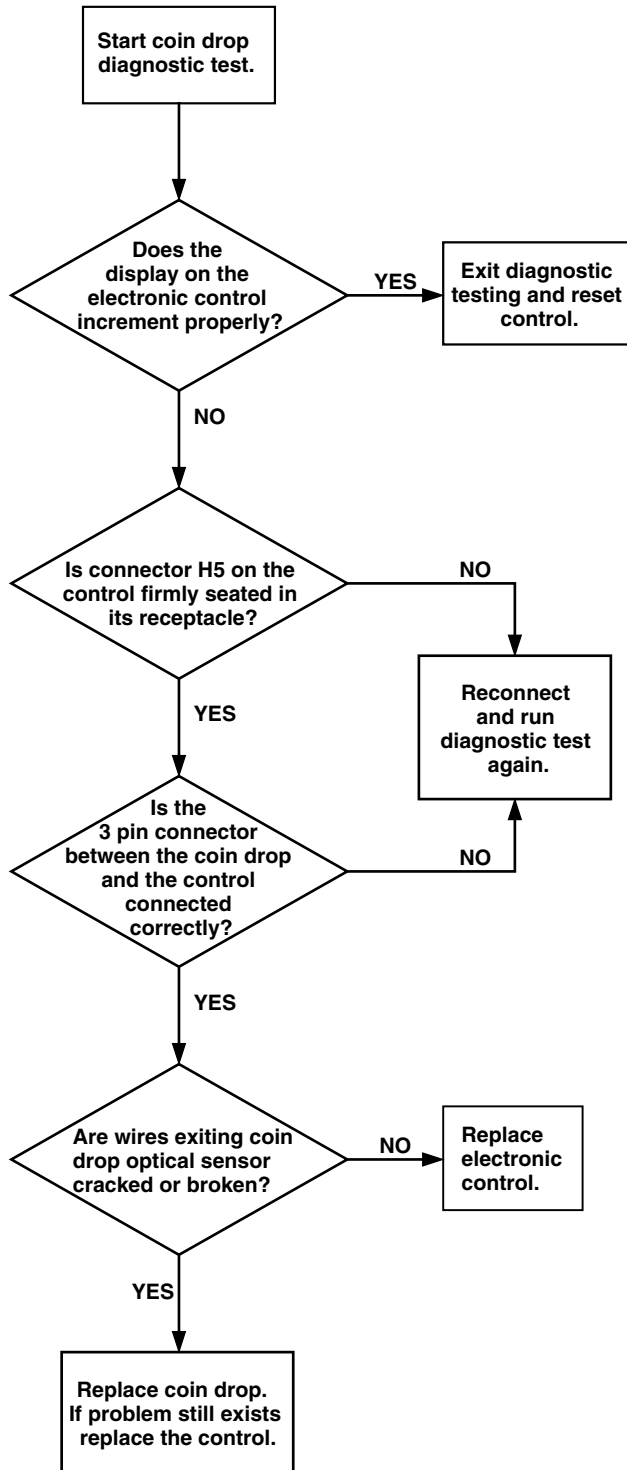

DRY353S

38. No IR Communication

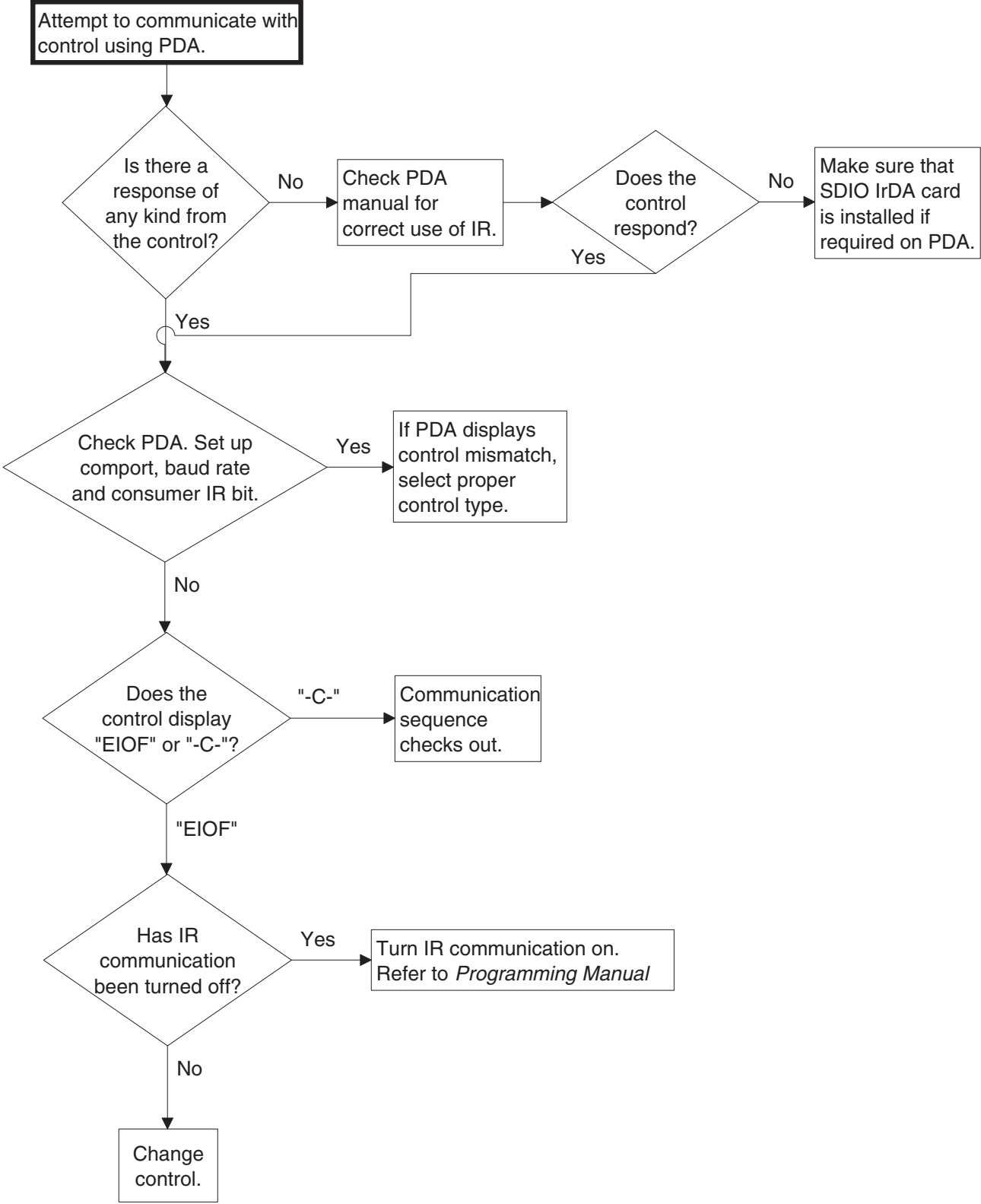

DRY1859S

39. No Display

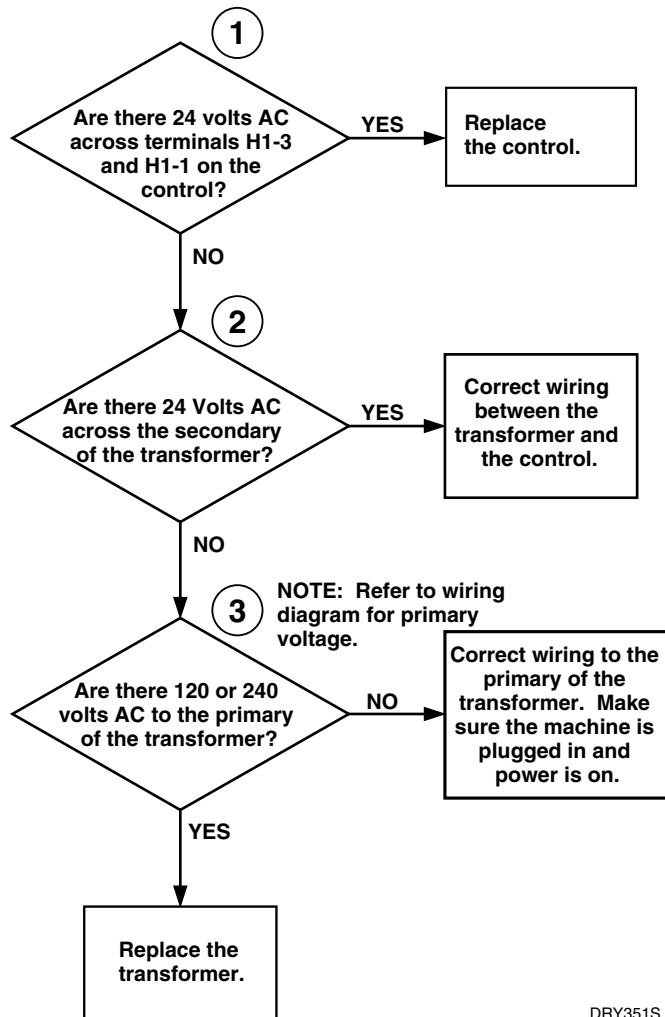

DRY351S

No Display

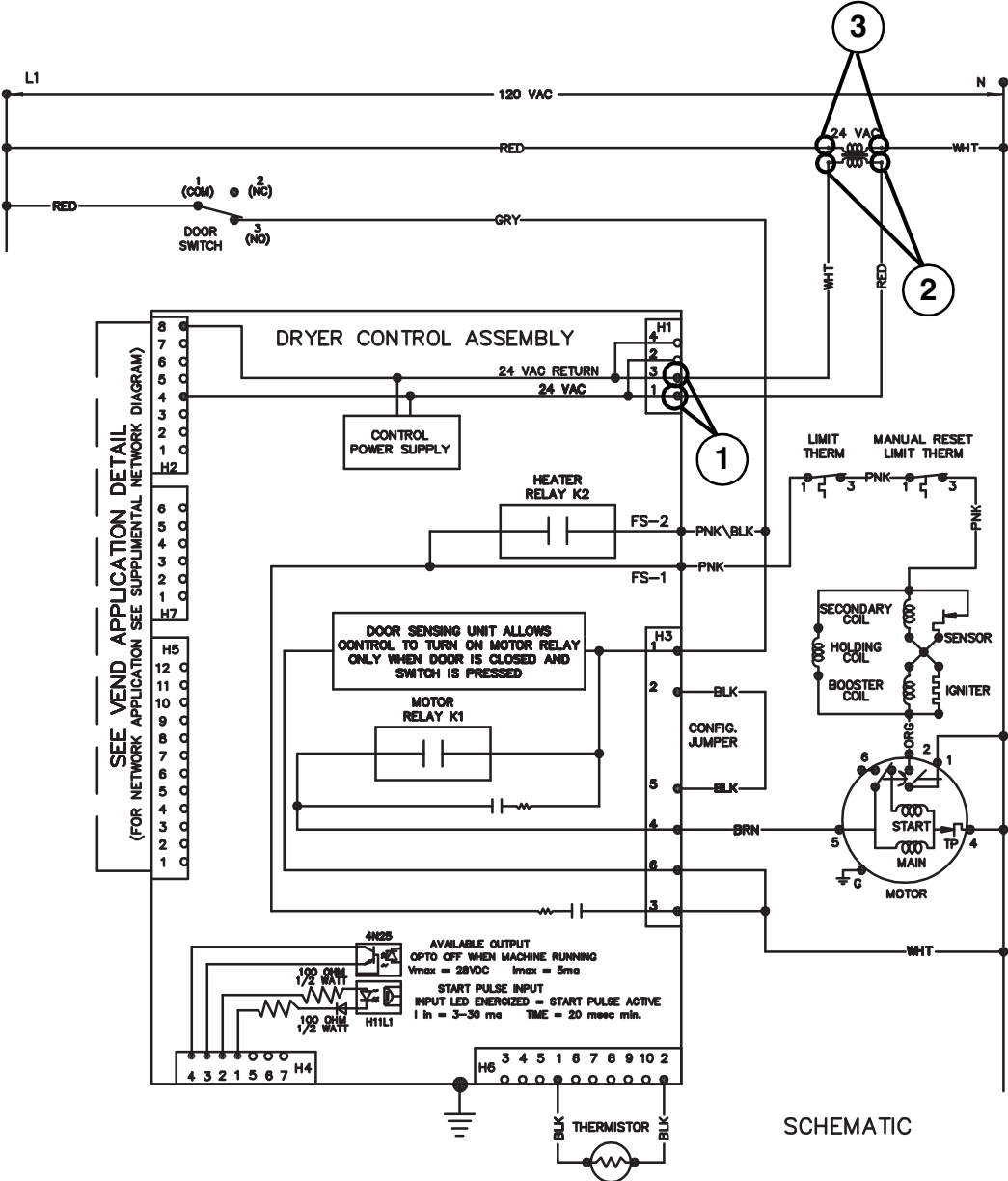

40. Door Open

NOTE: Conduct all tests with the door closed.

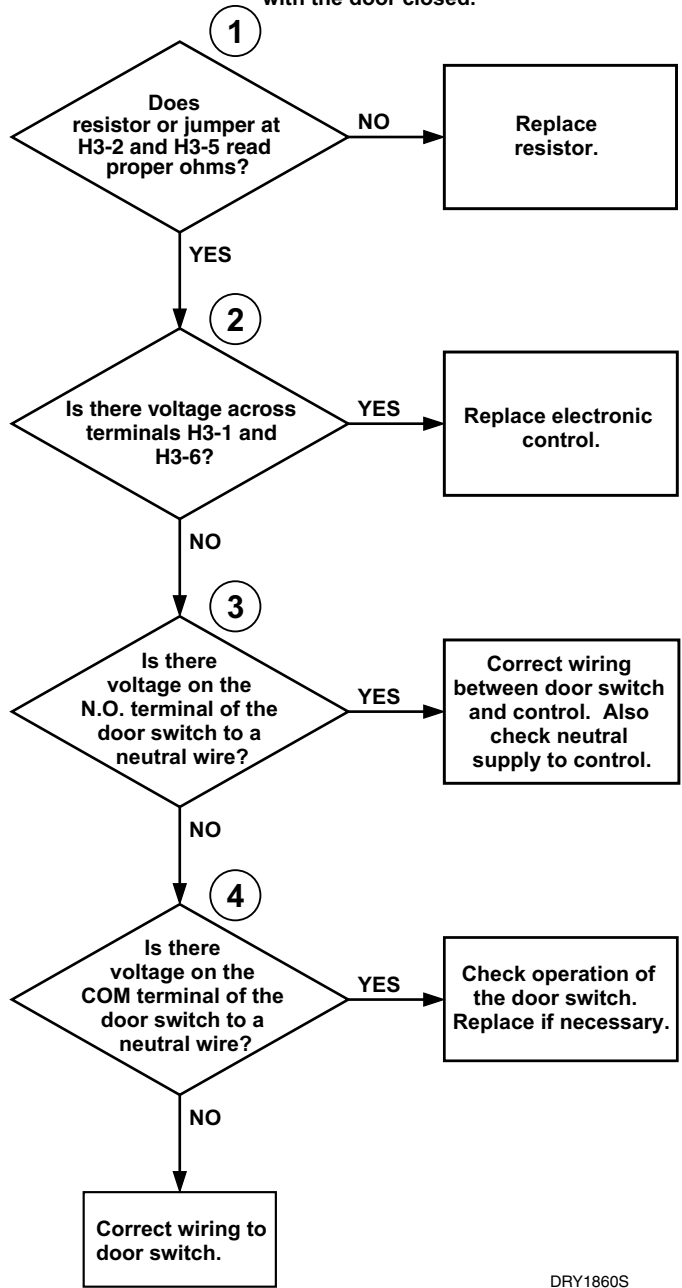

DRY1860S

Door Open

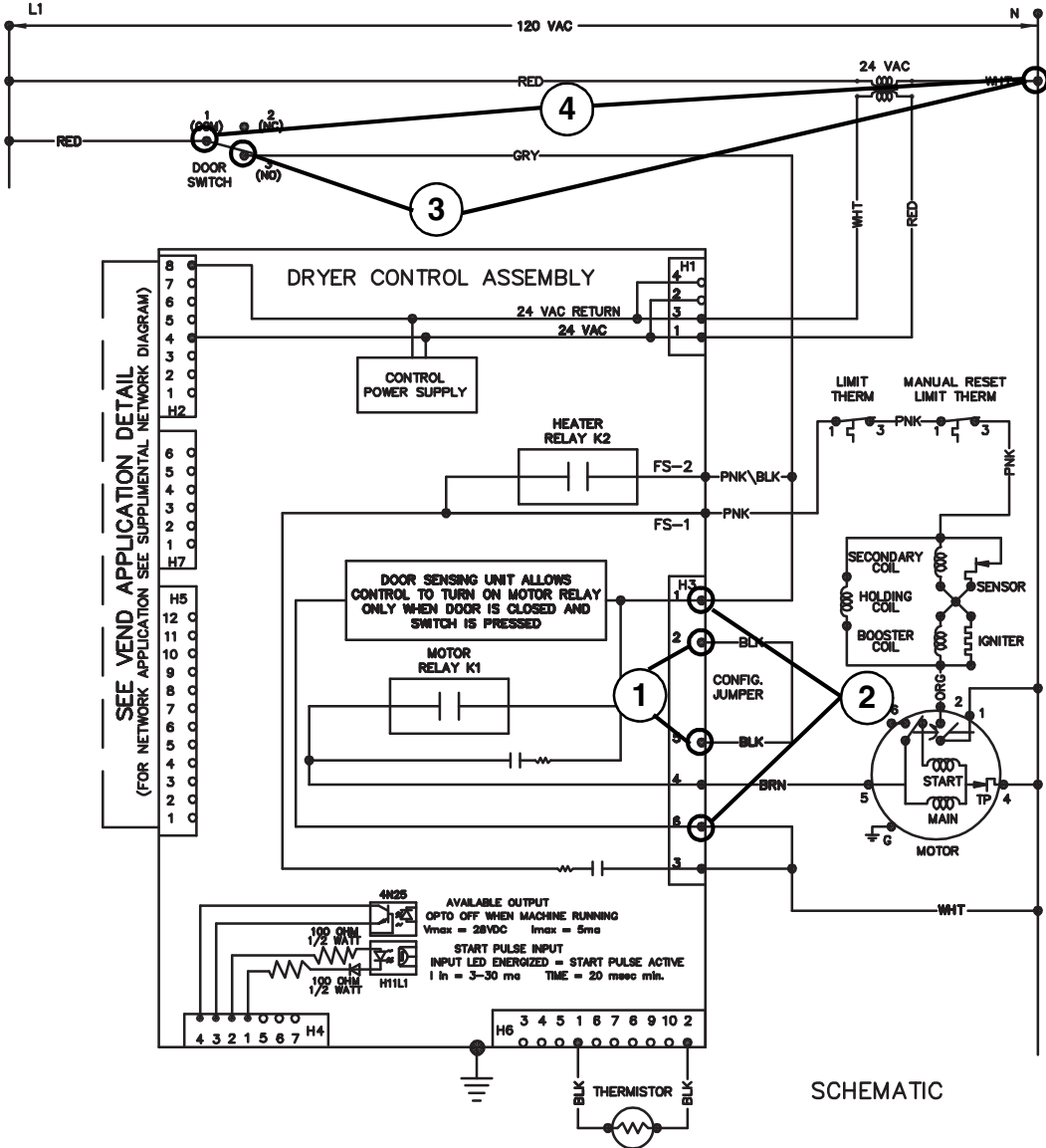

41. Motor Will Not Start

NOTE: Checks to be made only if motor does not start and "door" is not displayed on control. If "door" is displayed please refer to door open troubleshooting.

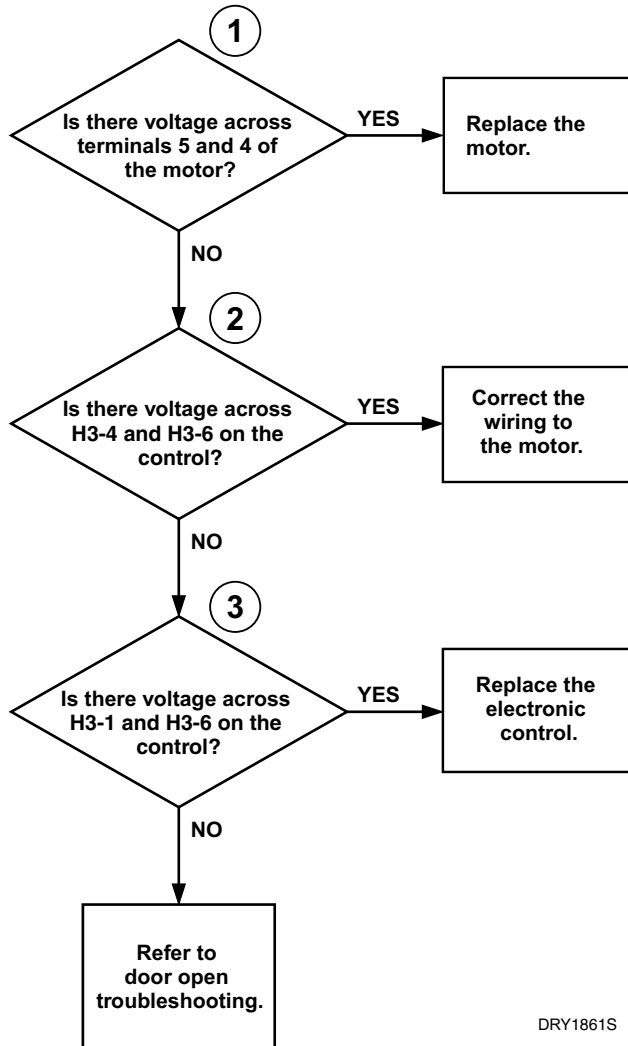

DRY1861S

Motor Will Not Start

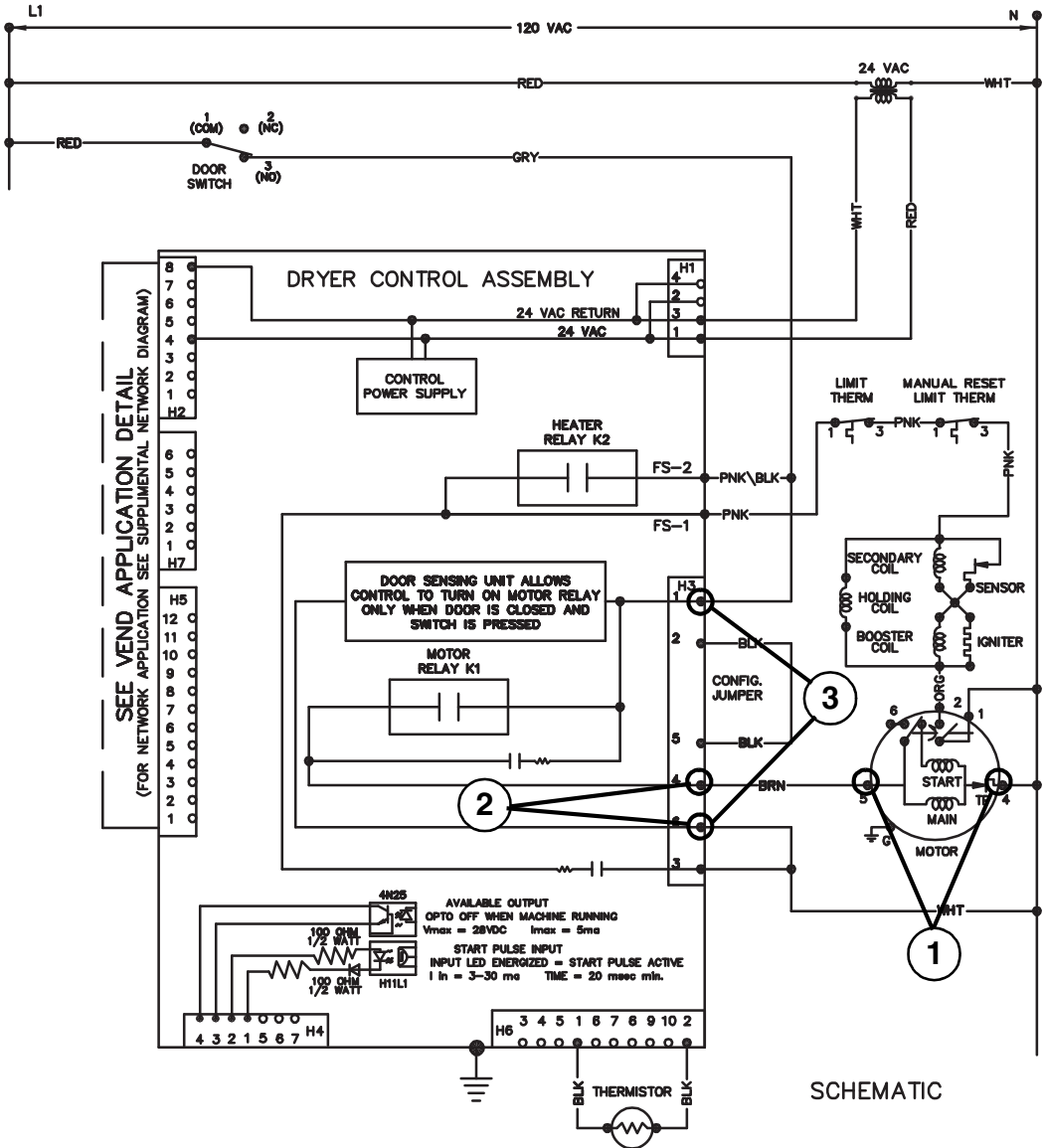

SCHEMATIC

DRY1863S

42. No Heat (Electric)

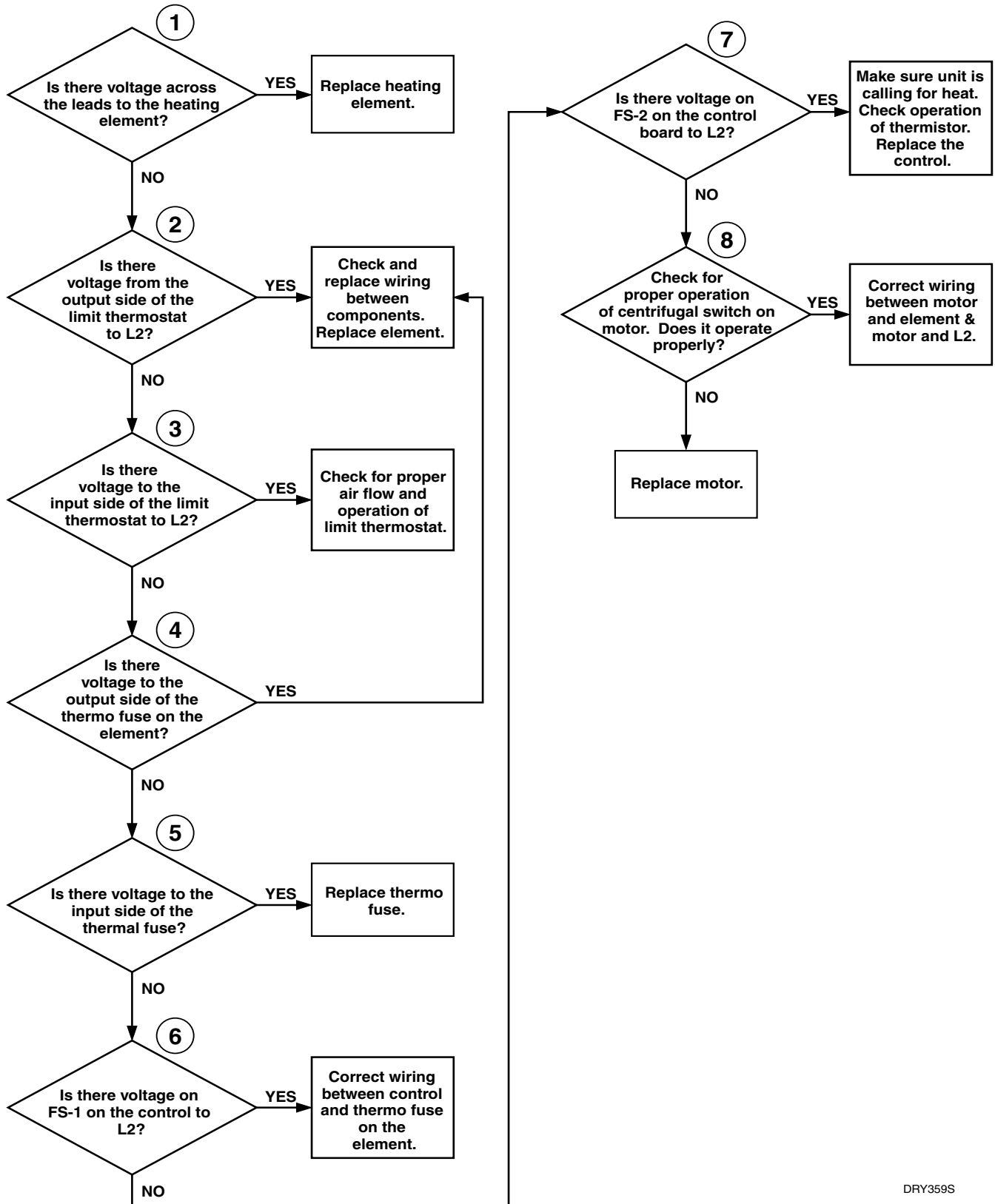

DRY359S

43. No Heat (Gas)

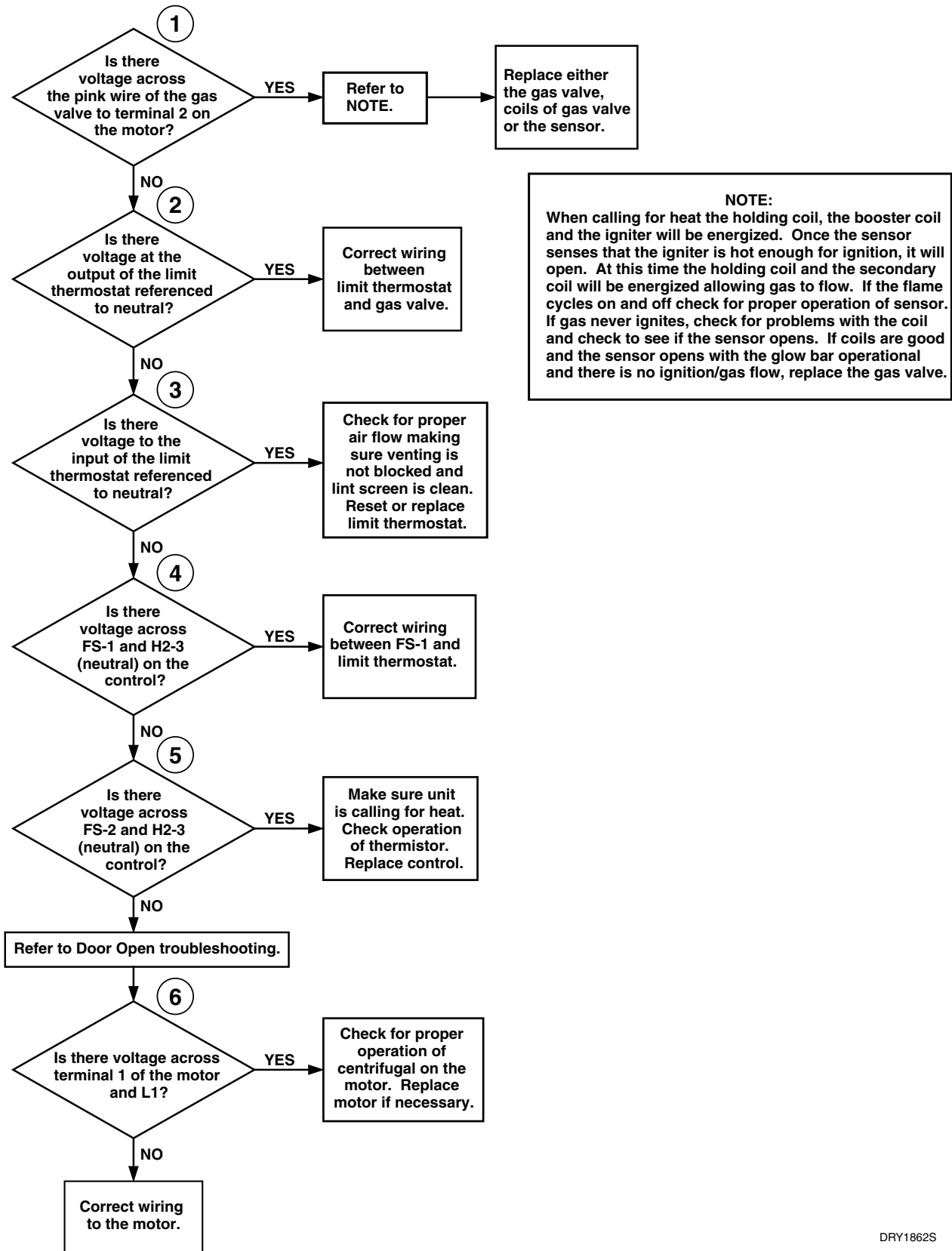

No Heat (Gas)

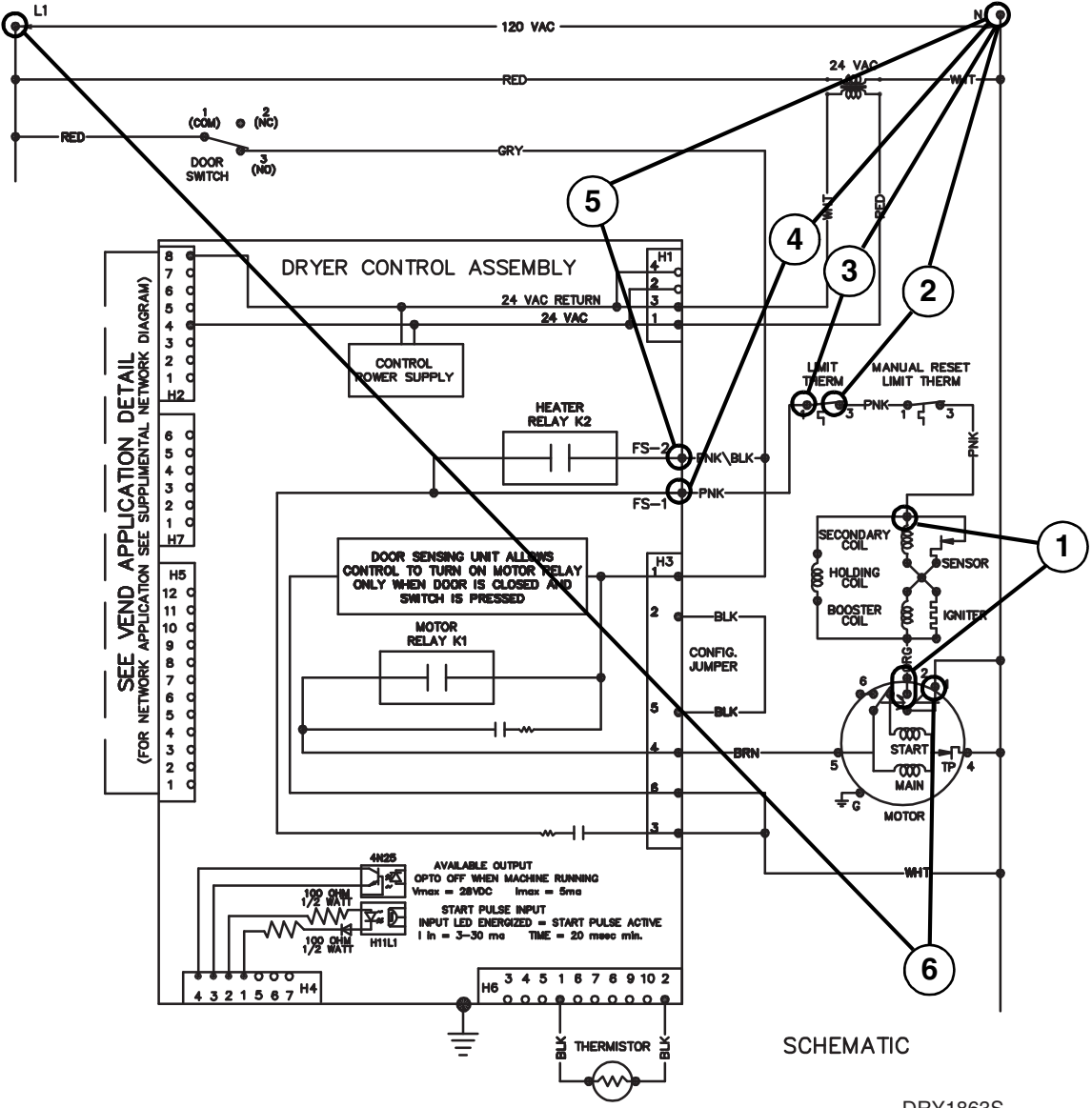

Section 7 Adjustments



WARNING

To reduce the risk of electric shock, fire, explosion, serious injury or death:

- Disconnect all electric power to the machine and accessories before servicing.
- Close gas shut-off valve to gas dryer before servicing.
- Never start machine with any guards/panels removed.
- Whenever ground wires are removed during servicing, these ground wires must be reconnected to ensure that the machine is properly grounded.
- Washer motor not grounded! Disconnect electric power before servicing motor.

W502

IMPORTANT: When reference is made to directions (right or left) in this manual, it is from operator's position facing front of washer.

44. Cabinet Leveling Legs

- Place unit in position on a solid, sturdy and level floor. Installing the unit on any type of carpeting, soft tile, a platform or other weakly supported structures is not recommended.
- Place a level on the cabinet top and check if unit is level from side to side and front to back.

NOTE: Level must be on a raised portion of top panel. Refer to *Figure 12*.

- If unit is not level, tilt unit to access front and rear leveling legs. For easier access to leveling legs, prop up unit with wooden block.
- Loosen locknuts and adjust the leveling legs until the unit is level from side to side and front to back (using a level). Make sure unit **does not rock**. Refer to *Figure 12*.
- Tighten the locknuts securely against the washer base. If the locknuts are not tight, washer will move out of position during operation.



CAUTION

DO NOT slide washer across floor if the leveling legs have been extended, as legs and base could become damaged.

W248



CAUTION

Use of the dispenser drawer or washer door as a handle in the transportation of the washer may cause damage to the dispenser or door.

W185

- Place rubber feet on all four leveling legs. Refer to *Figure 12*.
- Verify unit doesn't rock.

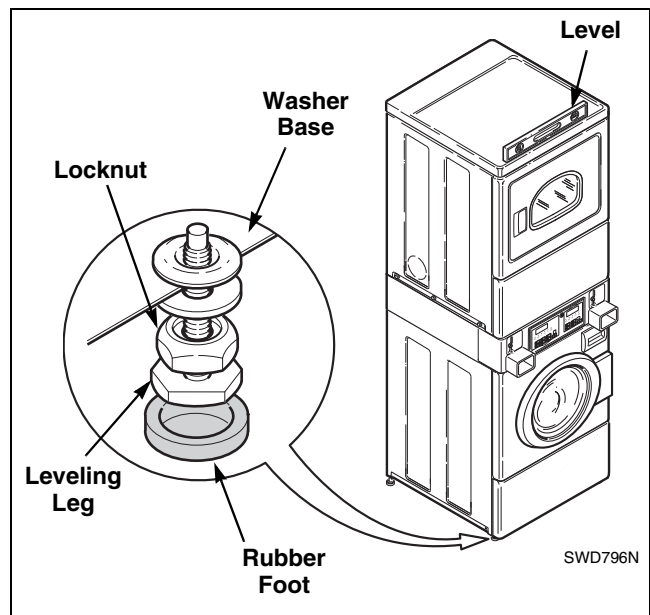

Figure 12



WARNING

To reduce the risk of electric shock, fire, explosion, serious injury or death:

- Disconnect all electric power to the machine and accessories before servicing.
- Close gas shut-off valve to gas dryer before servicing.
- Never start machine with any guards/panels removed.
- Whenever ground wires are removed during servicing, these ground wires must be reconnected to ensure that the machine is properly grounded.
- Washer motor not grounded! Disconnect electric power before servicing motor.

W502

45. Washer Loading Door

- a. Open loading door.
- b. The loading door can be adjusted up or down somewhat by loosening screws holding door hinge to front panel, then raise or lower door before retightening screws. Refer to *Figure 13*.

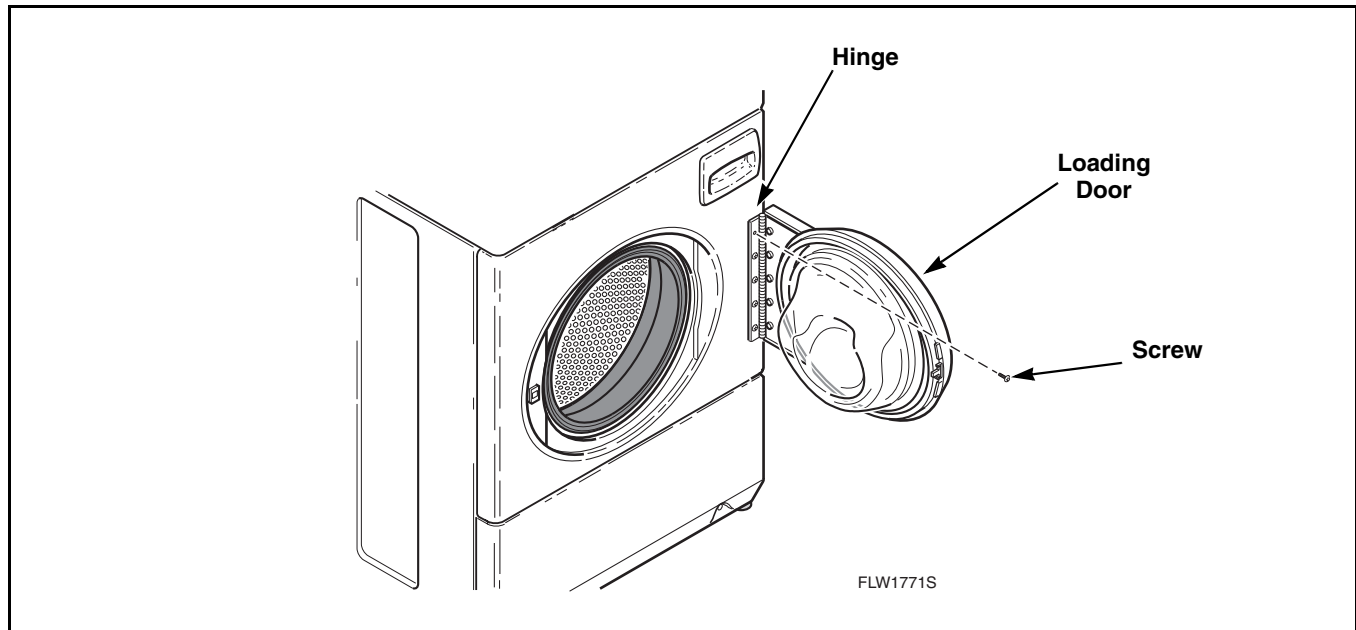

Figure 13



WARNING

To reduce the risk of electric shock, fire, explosion, serious injury or death:

- Disconnect all electric power to the machine and accessories before servicing.
- Close gas shut-off valve to gas dryer before servicing.
- Never start machine with any guards/panels removed.
- Whenever ground wires are removed during servicing, these ground wires must be reconnected to ensure that the machine is properly grounded.
- Washer motor not grounded! Disconnect electric power before servicing motor.

W502

46. Washer Motor Belt Tension

NOTE: Belt adjustment procedures are done through front of washer, however, as an option, washer can be moved from its location and belt adjustment can be done through lower access panel opening on rear panel.

- While supporting lower front access panel, remove two screws from bottom edge of access panel and remove panel.
- Working through the access door opening, place a locking pliers on the metal rod and loosen the two adjusting bolts. Refer to *Figure 14*. Repeat procedure to loosen the two pivot bolts. Refer to *Figure 14*.
- Pull down on motor to increase belt tension. Use a Burroughs belt gauge to obtain proper tension. Proper belt tension is obtained when belt can be deflected approximately 1/4 inch (6.35 mm) from normal position when moderate pressure 50 to 60 pounds (22.68 to 27.22 Kg) is applied to a point midway between pulleys. Refer to *Figure 14*.
- After proper belt tension has been obtained, tighten belt adjusting bolts firmly, then tighten pivot bolts. Refer to *Figure 14*.

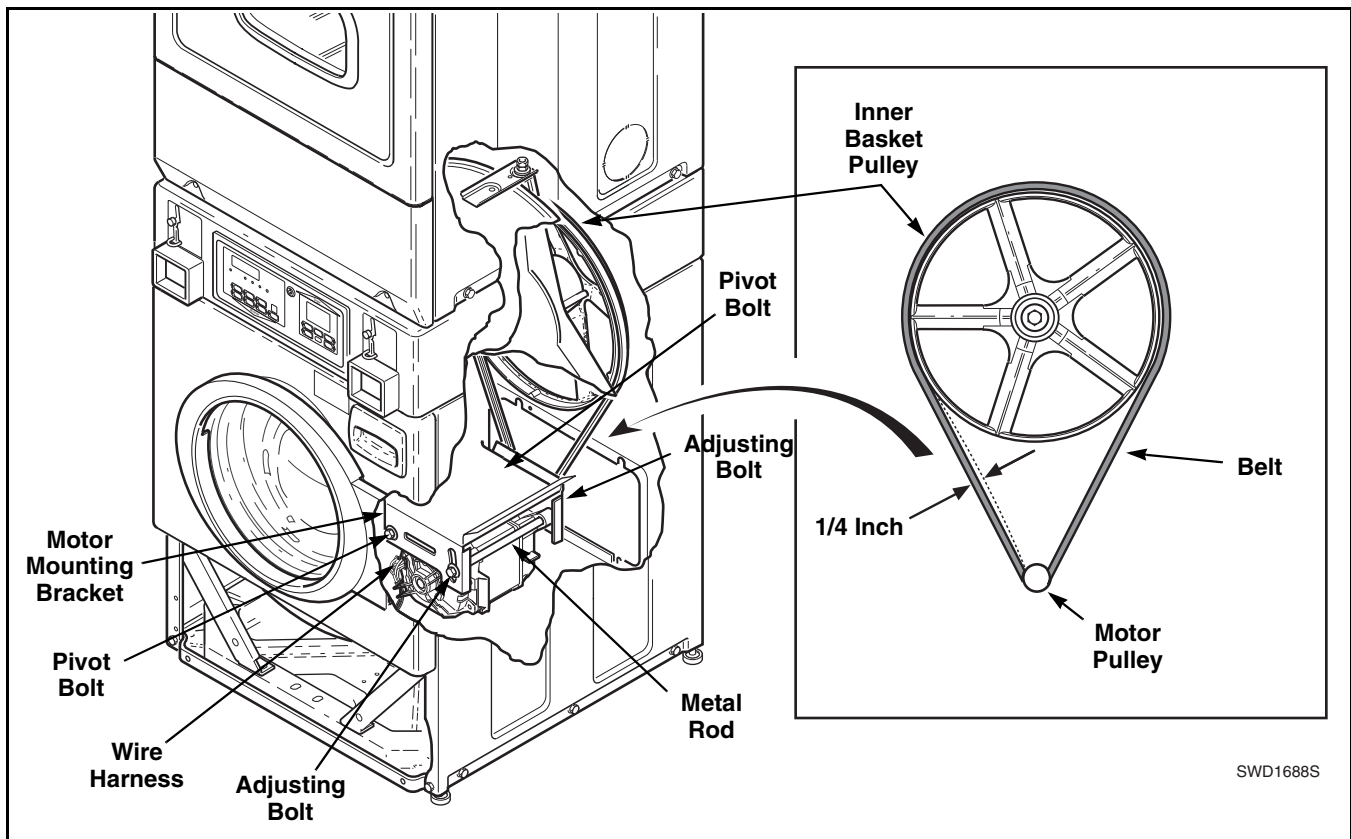

SWD1688S

Figure 14



WARNING

To reduce the risk of electric shock, fire, explosion, serious injury or death:

- Disconnect all electric power to the machine and accessories before servicing.
- Close gas shut-off valve to gas dryer before servicing.
- Never start machine with any guards/panels removed.
- Whenever ground wires are removed during servicing, these ground wires must be reconnected to ensure that the machine is properly grounded.
- Washer motor not grounded! Disconnect electric power before servicing motor.

W502

47. Washer Door Catch

NOTE: When repairing a broken or inoperative No. 802803 Door Catch, proceed as follows:

- a. Open loading door.
- b. Remove 11 T-20 Torx head screws holding outer door bezel to inner door bezel. Refer to *Figure 15*.
- c. Pull hinge side of outer bezel away from door and slide forward. Refer to *Figure 15*.
- d. Remove two screws and nuts holding door catch to door and remove door catch.
- e. Install new door catch and tighten screws and nuts to the point of being snug.
- f. Adjust door catch so the outside edge is aligned with the edge of the lock. Refer to *Figure 16*.
- g. Visually check that the door catch properly engages the funnel of the door latch/switch assembly. Refer to *Figure 16*.
- h. Recheck the alignment in Step f. Adjust if needed.
- i. Torque the two nuts to approximately 20 inch pounds (2.25 Nm).
- j. Reinstall outer door bezel by aligning outer bezel tabs with cut aways on inner bezel and sliding outer bezel into position. Refer to *Figure 15*.
- k. Replace 11 screws holding outer door bezel to inner door bezel.

IMPORTANT: Do not overtighten screws or bezel holes will strip.

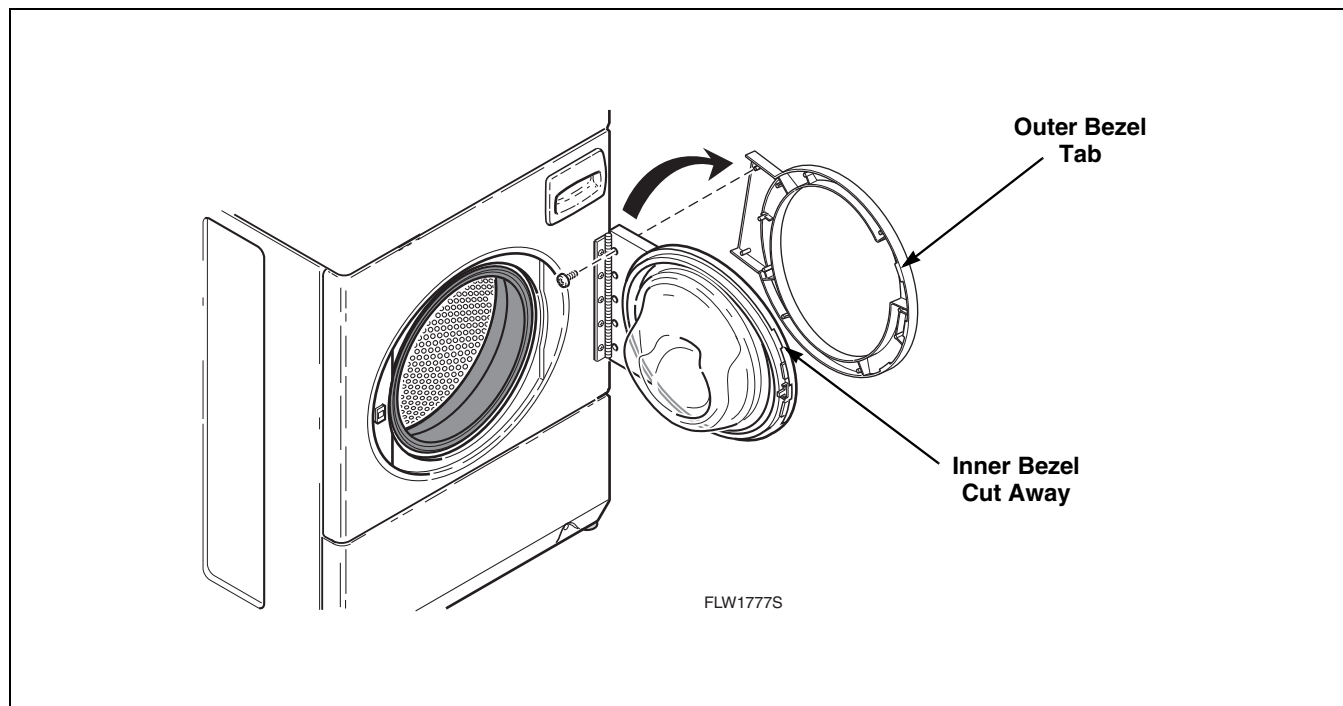

Figure 15



WARNING

To reduce the risk of electric shock, fire, explosion, serious injury or death:

- Disconnect all electric power to the machine and accessories before servicing.
- Close gas shut-off valve to gas dryer before servicing.
- Never start machine with any guards/panels removed.
- Whenever ground wires are removed during servicing, these ground wires must be reconnected to ensure that the machine is properly grounded.
- Washer motor not grounded! Disconnect electric power before servicing motor.

W502

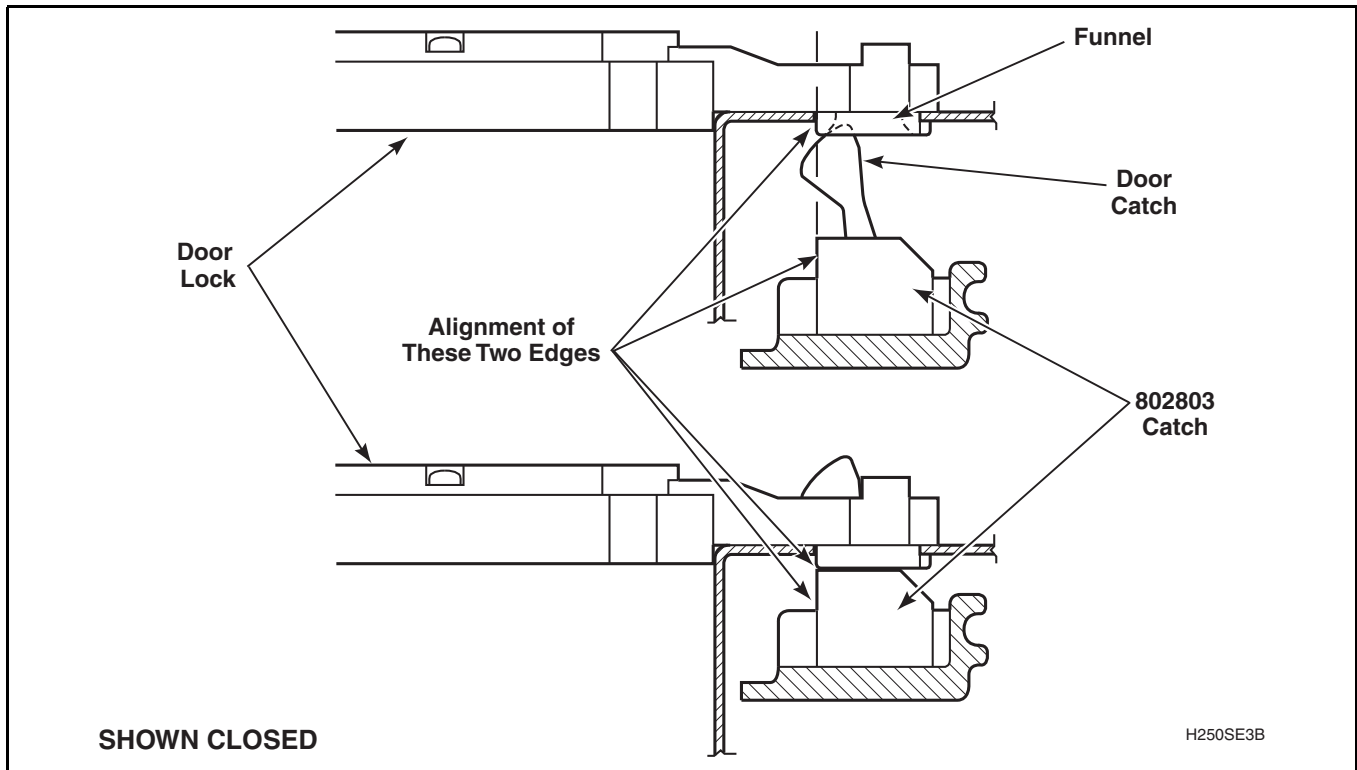

Figure 16



WARNING

To reduce the risk of electric shock, fire, explosion, serious injury or death:

- Disconnect all electric power to the machine and accessories before servicing.
- Close gas shut-off valve to gas dryer before servicing.
- Never start machine with any guards/panels removed.
- Whenever ground wires are removed during servicing, these ground wires must be reconnected to ensure that the machine is properly grounded.
- Washer motor not grounded! Disconnect electric power before servicing motor.

W502

48. Shipping Braces

All stacked washer/dryers, when shipped from the factory are equipped with two factory installed shipping supports. DO NOT remove this shipping material until after machine is placed in its final installed position. Refer to *Figure 17*.

damage to the shock absorbers and will VOID the product warranty.

NOTE: Shipping supports MUST be kept for future re-positioning or moving of the machine.

IMPORTANT: DO NOT tip or move washer once these supports have been removed. Removal of supports prior to final installation may cause

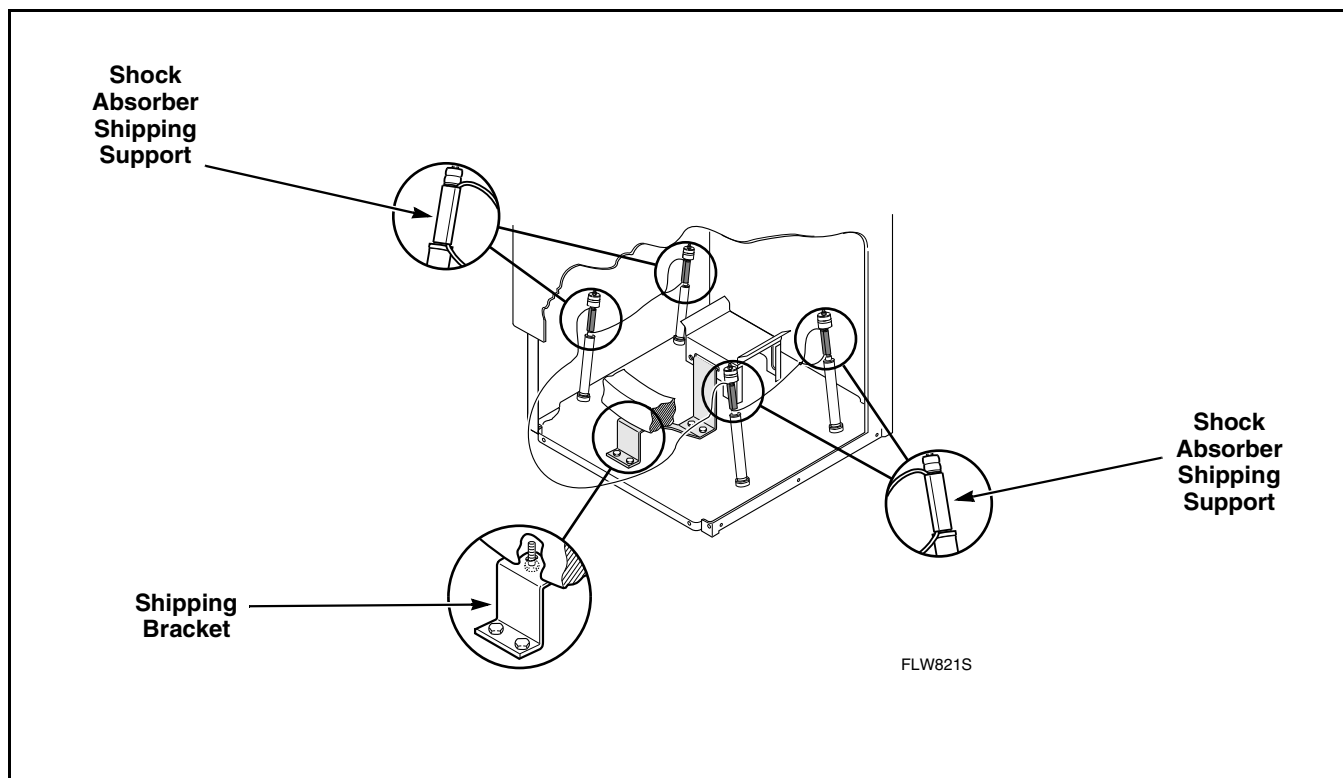

Figure 17



WARNING

To reduce the risk of electric shock, fire, explosion, serious injury or death:

- Disconnect all electric power to the machine and accessories before servicing.
- Close gas shut-off valve to gas dryer before servicing.
- Never start machine with any guards/panels removed.
- Whenever ground wires are removed during servicing, these ground wires must be reconnected to ensure that the machine is properly grounded.
- Washer motor not grounded! Disconnect electric power before servicing motor.

W502

49. Burner Flame (Gas Models)

- While supporting the access panel, remove two screws from bottom edge of access panel.
- Gently lower the access panel to disengage locators from bottom edge of front panel.
- Add coins or card to satisfy vend.
- Close the loading door. Start the dryer in a heat setting (refer to Operating Instructions supplied with the dryer). The dryer will start, the igniter will glow red, and the main burner will ignite.
- Allow the dryer to operate for approximately five minutes, then loosen the air shutter lockscrew. Refer to *Figure 18*.
- Turn the air shutter to the left to get a luminous yellow tipped flame, then turn it back slowly to the right to obtain a steady blue flame.

- After proper flame is obtained, tighten air shutter lockscrew firmly. Refer to *Figure 18*.
- Reinstall access panel and screws.



WARNING

To reduce the risk of fire or serious injury, the access panel must be in place during normal operation.

W262

NOTE: After the dryer has operated for approximately three minutes, exhaust air or exhaust pipe should be warm.

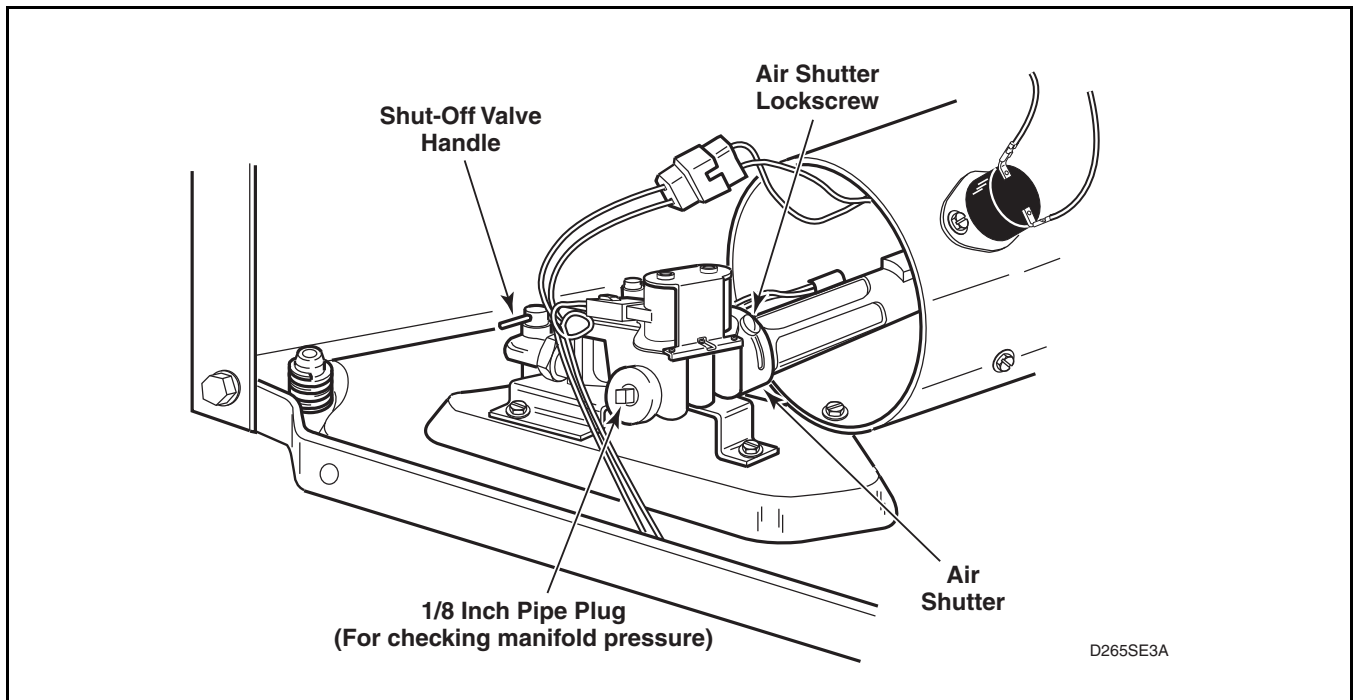

Figure 18



WARNING

To reduce the risk of electric shock, fire, explosion, serious injury or death:

- Disconnect all electric power to the machine and accessories before servicing.
- Close gas shut-off valve to gas dryer before servicing.
- Never start machine with any guards/panels removed.
- Whenever ground wires are removed during servicing, these ground wires must be reconnected to ensure that the machine is properly grounded.
- Washer motor not grounded! Disconnect electric power before servicing motor.

W502

50. Cleaning Non-Electronic Coin Drop

- Disconnect electrical power to machine and drop.
- Remove coin drop from machine.
- If lint is preventing coins from rolling through coin drop, blow compressed air through coin entry and along the side of the coin drop. Refer to *Figure 19*.

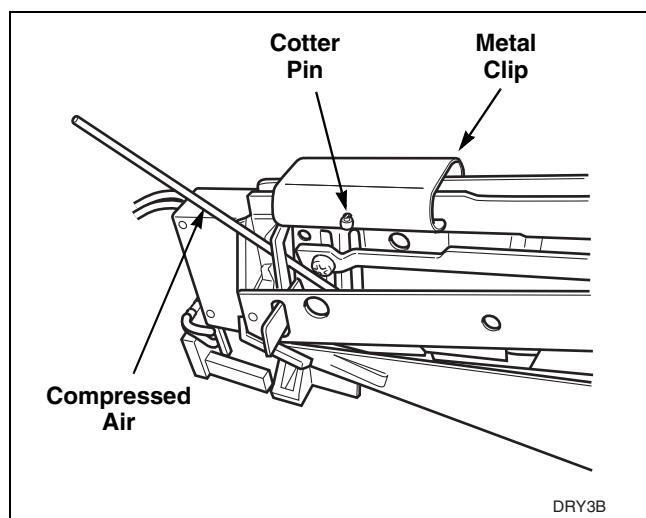

Figure 19

- Insert a coin through the coin drop. If coin does not roll through drop, continue with the following.
- Remove cotter pin from top of drop. Refer to *Figure 19*. Save pin for reinstallation when cleaning is complete.
- Move metal clip closer to sensor so that it comes off frame. Refer to *Figure 19*.

- Remove coin return from coin drop frame. Refer to *Figure 20*.

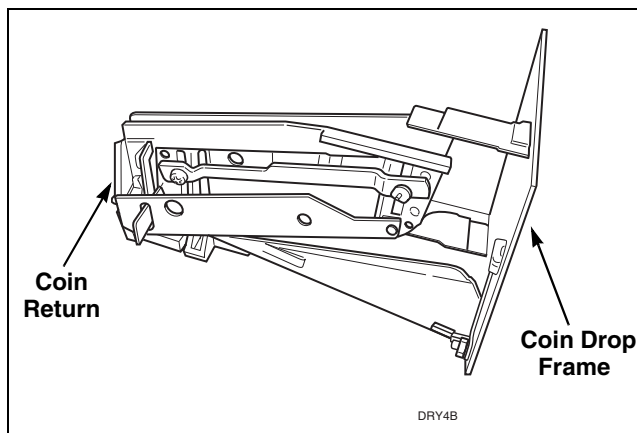

Figure 20

- Check coin path in coin drop for lint and residue. If lint or light residues are present, use a cotton swab to remove. If heavy residue is present, it may be necessary to first scrape off excessive residue and then use a cotton swab dipped in water or isopropyl alcohol (rubbing alcohol) to remove remainder of residue. Refer to *Figure 21*.

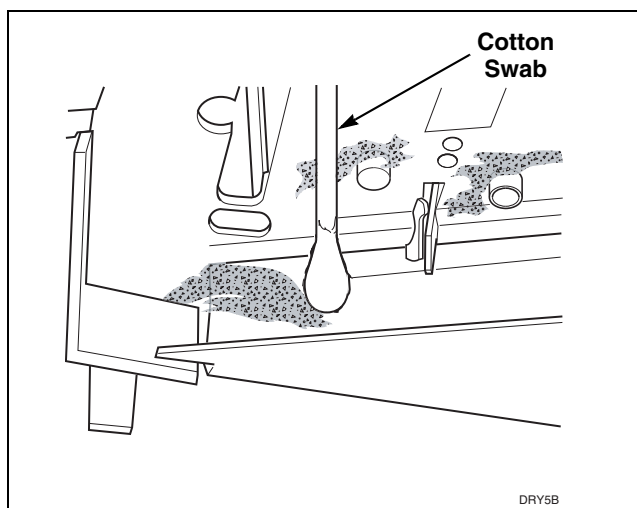

Figure 21



WARNING

To reduce the risk of electric shock, fire, explosion, serious injury or death:

- Disconnect all electric power to the machine and accessories before servicing.
- Close gas shut-off valve to gas dryer before servicing.
- Never start machine with any guards/panels removed.
- Whenever ground wires are removed during servicing, these ground wires must be reconnected to ensure that the machine is properly grounded.
- Washer motor not grounded! Disconnect electric power before servicing motor.

W502

- i. Check coin return pendulum to verify it swings freely. If pendulum does not swing freely, spray pendulum pivot point with Teflon based lubricant and move pendulum back and forth two to three times. An additional application of Teflon based lubricant may be necessary to ensure that pendulum swings freely. Refer to *Figure 22*.

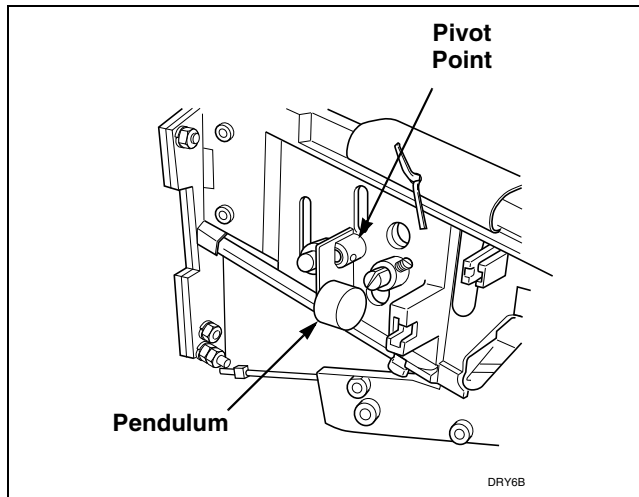

Figure 22

- j. Check coin drop sensor for dust or dirt on eyes. Wipe eyes with dry cotton swab. Refer to *Figure 23*.

IMPORTANT: DO NOT use isopropyl alcohol to clean electronic sensor or eyes.

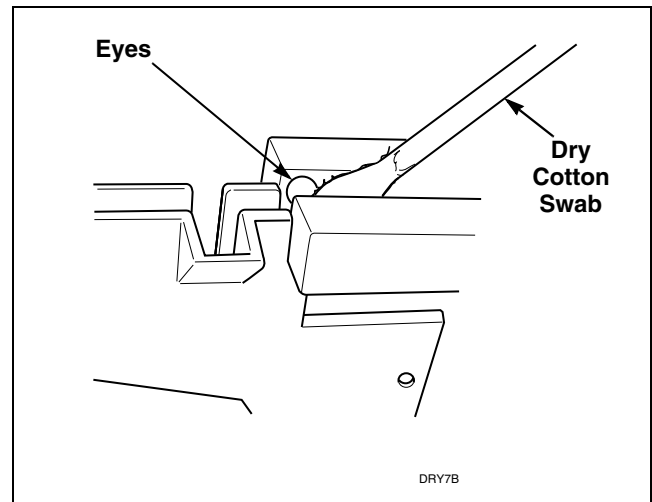

Figure 23

- k. Reinstall coin return on to coin drop frame.
 l. Reinstall metal clip and slide towards coin insert slot. All cotter pin holes must line up.
 m. Reinstall cotter pin.
 n. Place drop on level surface to verify that coins follow correct path in drop. It may be necessary to lift drop to allow coin to follow through sensor.
 o. Reinstall coin drop into machine.
 p. Reconnect electrical power to machine and drop.
 q. Add a coin to drop to verify that coin drop is operating properly and that electrical connection is working properly.

NOTE: If coin drop does not operate properly after above steps have been completed, corrosion of metal or vandalized components within coin drop may be preventing the coin drop from functioning correctly. Replace coin drop.



WARNING

To reduce the risk of electric shock, fire, explosion, serious injury or death:

- Disconnect all electric power to the machine and accessories before servicing.
- Close gas shut-off valve to gas dryer before servicing.
- Never start machine with any guards/panels removed.
- Whenever ground wires are removed during servicing, these ground wires must be reconnected to ensure that the machine is properly grounded.
- Washer motor not grounded! Disconnect electric power before servicing motor.

W502

51. Cleaning Electronic Coin Drop

NOTE: The electronic coin drop should be cleaned once a year. Clean the drop more often if it is exposed to high levels of residue or lint build-up.

- Disconnect electrical power to machine and drop.
- Remove coin drop from machine.
- Check the spring style of coin drop.

Coin Drops with Old-Style Spring (refer to Figure 24):

- Move spring downward until cover catch is free. Refer to Figure 24.

NOTE: Do not lift or overbend the spring in any direction.

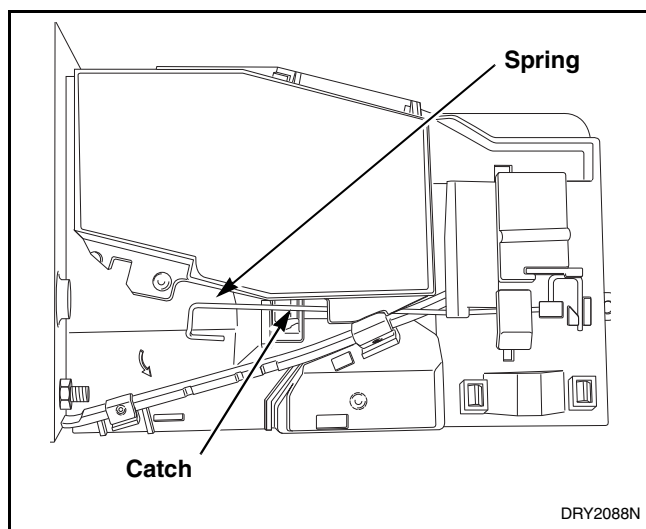

Figure 24

- Open cover for coin drop. Refer to Figure 25.

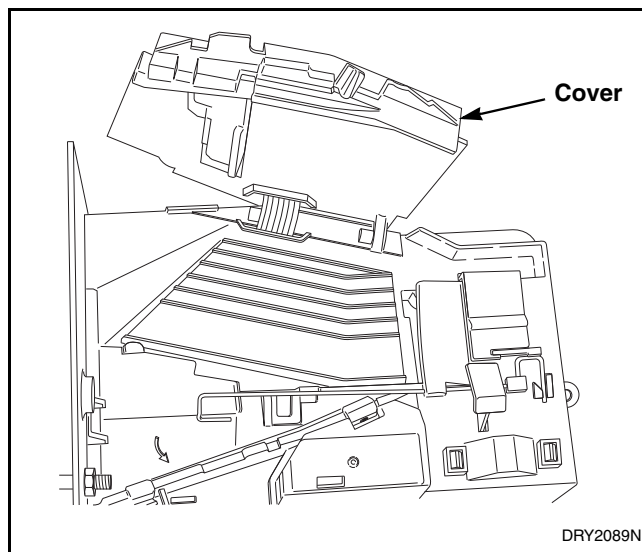

Figure 25

Coin Drops with New-Style Spring (refer to Figure 26):

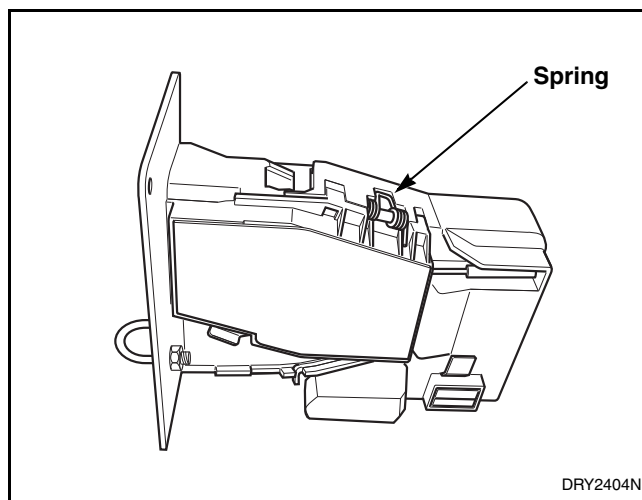

Figure 26

- Open cover of coin drop. Refer to Figure 27.



WARNING

To reduce the risk of electric shock, fire, explosion, serious injury or death:

- Disconnect all electric power to the machine and accessories before servicing.
- Close gas shut-off valve to gas dryer before servicing.
- Never start machine with any guards/panels removed.
- Whenever ground wires are removed during servicing, these ground wires must be reconnected to ensure that the machine is properly grounded.
- Washer motor not grounded! Disconnect electric power before servicing motor.

W502

NOTE: Do not overbend the spring by opening cover too far.

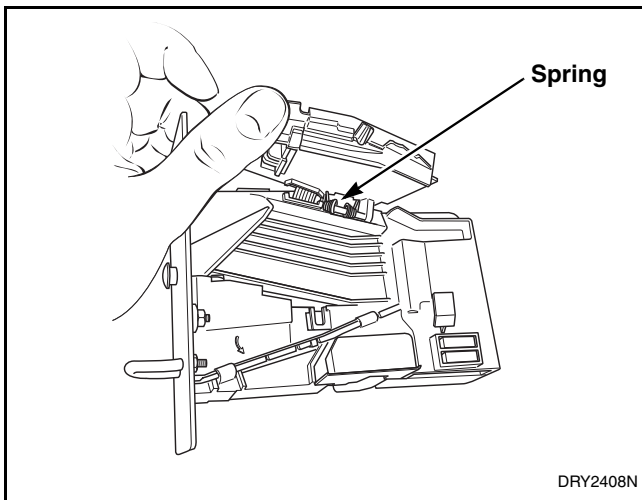

Figure 27

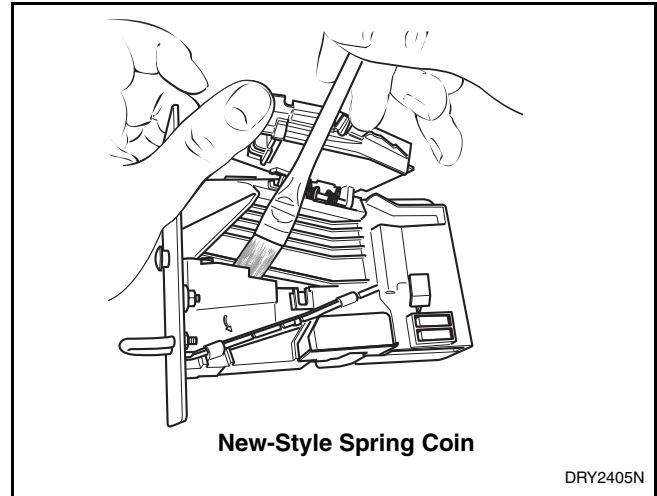

Figure 29

- d. Clean the coin path with a soft brush and wipe exposed surfaces with an alcohol moistened cloth. Refer to *Figure 28* or *Figure 29*.

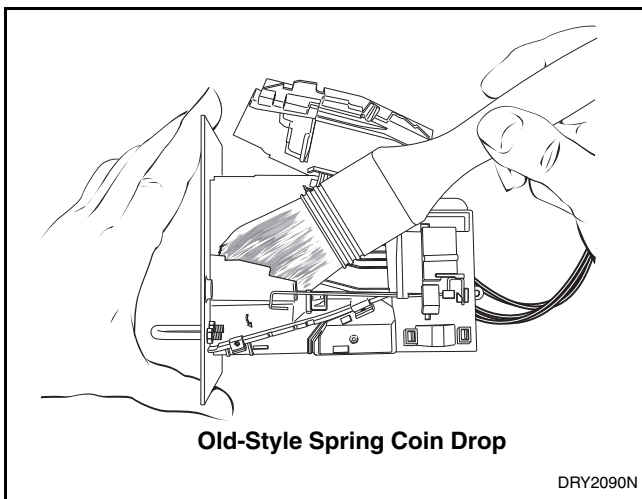

Figure 28

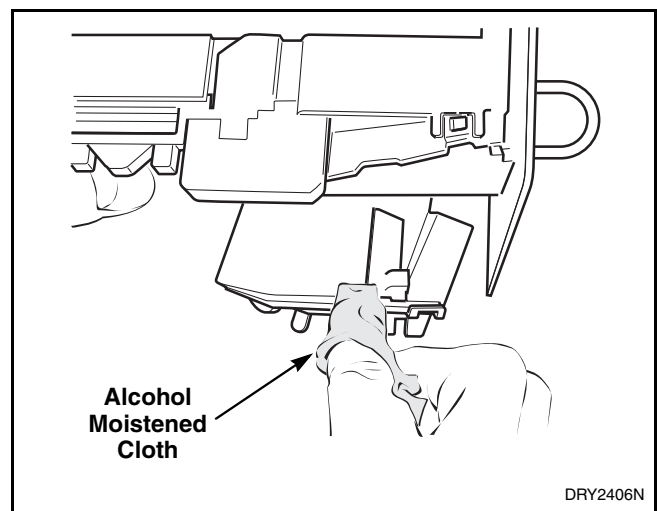

Figure 30

- e. Clean residue from coin rail with an alcohol moistened cloth. Refer to *Figure 30*.



WARNING

To reduce the risk of electric shock, fire, explosion, serious injury or death:

- Disconnect all electric power to the machine and accessories before servicing.
- Close gas shut-off valve to gas dryer before servicing.
- Never start machine with any guards/panels removed.
- Whenever ground wires are removed during servicing, these ground wires must be reconnected to ensure that the machine is properly grounded.
- Washer motor not grounded! Disconnect electric power before servicing motor.

W502

- f. Clean light sensors with a soft brush or air spray duster. Refer to *Figure 31*.

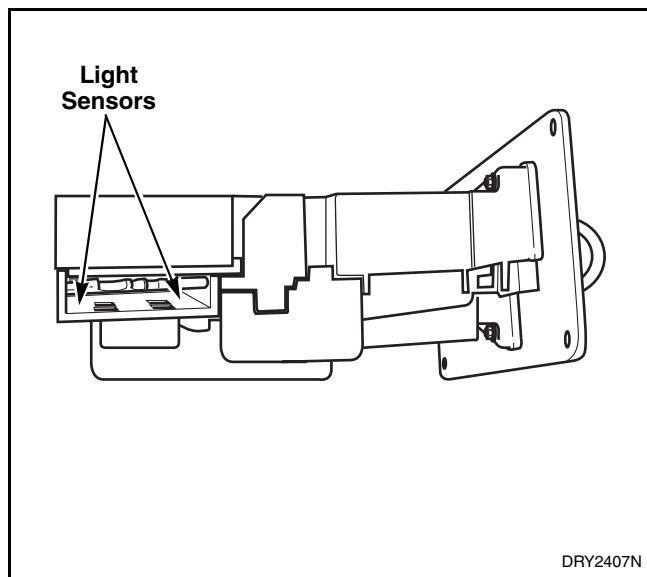

Figure 31

- g. Close cover for coin drop.
- h. **Coin Drops with OLD-Style Spring** - Move spring back over cover catch.
- i. Reinstall coin drop into machine.
- j. Reconnect electrical power to machine and drop.
- k. Add a coin to drop to verify that coin drop is operating properly and that electrical connection is working properly.

Section 8

Dryer Test Procedures



WARNING

To reduce the risk of electric shock, fire, explosion, serious injury or death:

- Disconnect all electric power to the machine and accessories before servicing.
- Close gas shut-off valve to gas dryer before servicing.
- Never start machine with any guards/panels removed.
- Whenever ground wires are removed during servicing, these ground wires must be reconnected to ensure that the machine is properly grounded.
- Washer motor not grounded! Disconnect electric power before servicing motor.

W502

IMPORTANT: Electrical test procedures in this service manual are performed by using a Volt-Ohm meter. Tests can also be performed using a multi-meter or any other electrical testing equipment with which the service person is familiar.

- Disconnect motor wire harness at motor disconnect block.

NOTE: Refer to wiring diagram for internal motor switch wires.

52. Drive Motor

Refer to *Figure 32*.

- Remove motor and exhaust assembly.

NOTE: Drive Motor Resistance

120 Volt 2,460 – 3,100 Ohms

240 Volt 10,000 - 13,000 Ohms

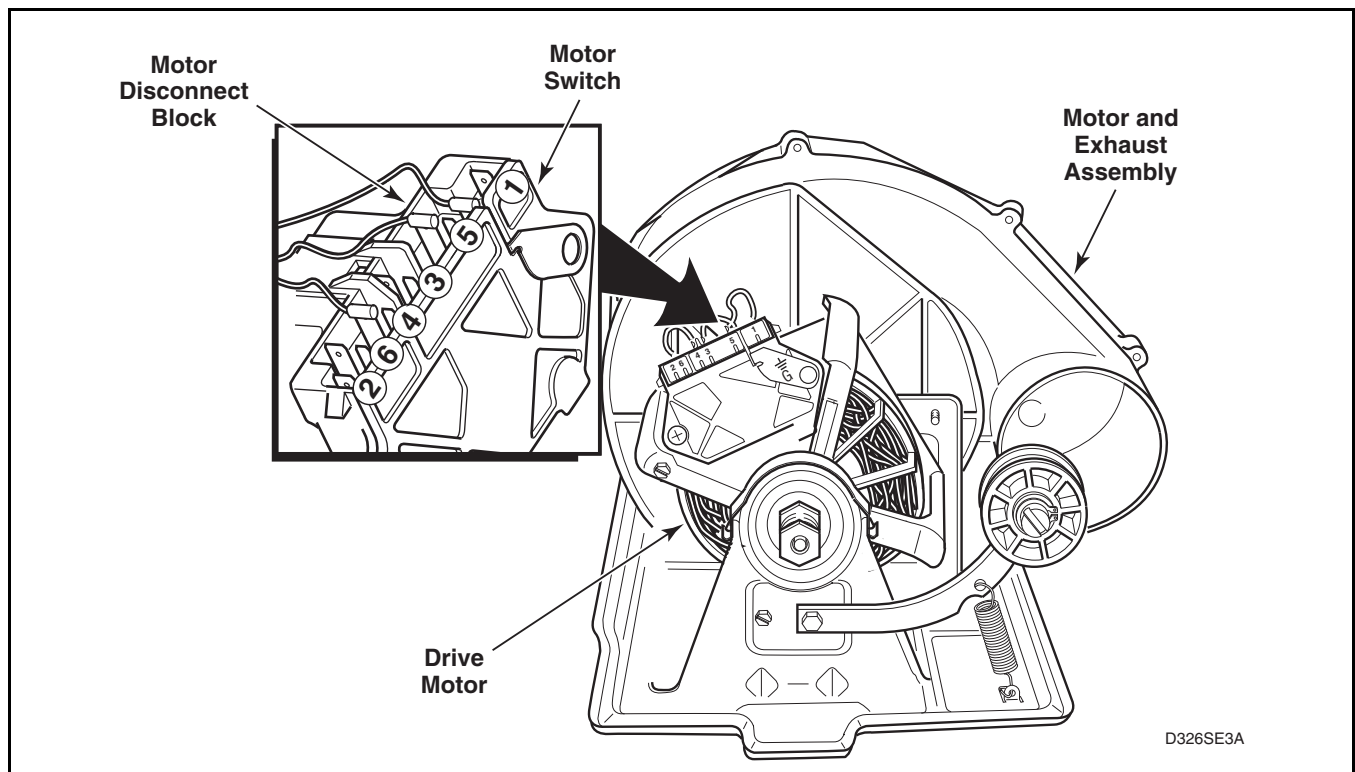

Figure 32



WARNING

- To reduce the risk of electric shock, fire, explosion, serious injury or death:
- Disconnect all electric power to the machine and accessories before servicing.
 - Close gas shut-off valve to gas dryer before servicing.
 - Never start machine with any guards/panels removed.
 - Whenever ground wires are removed during servicing, these ground wires must be reconnected to ensure that the machine is properly grounded.
 - Washer motor not grounded! Disconnect electric power before servicing motor.

W502

c. **Motor Switch** (Refer to SECTION 10 for Internal Wiring of the Dryer Motor Switch.)



WARNING

Disconnect electric power to dryer before performing any of the following steps or when replacing inoperative motor switch.

W290

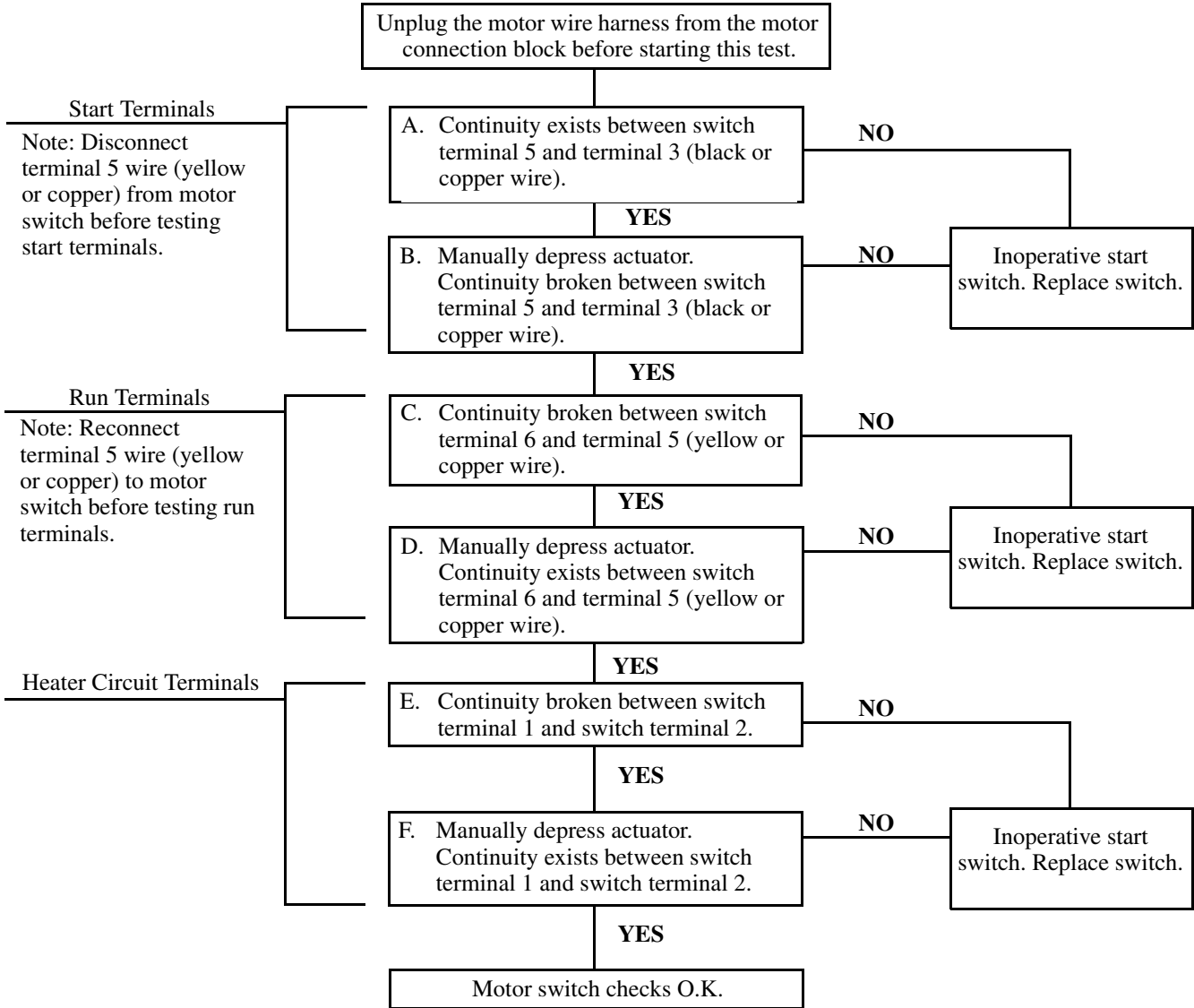

	<h2 style="margin: 0;">WARNING</h2>
<p>To reduce the risk of electric shock, fire, explosion, serious injury or death:</p> <ul style="list-style-type: none"> • Disconnect all electric power to the machine and accessories before servicing. • Close gas shut-off valve to gas dryer before servicing. • Never start machine with any guards/panels removed. • Whenever ground wires are removed during servicing, these ground wires must be reconnected to ensure that the machine is properly grounded. • Washer motor not grounded! Disconnect electric power before servicing motor. 	
<small>W502</small>	

d. **Motor Windings** (Refer to SECTION 10 for Internal Wiring of the Dryer Motor Switch.)

	<h2 style="margin: 0;">WARNING</h2>
<p>Disconnect electric power to dryer before performing any of the following steps or when replacing inoperative motor switch.</p>	
<small>W290</small>	

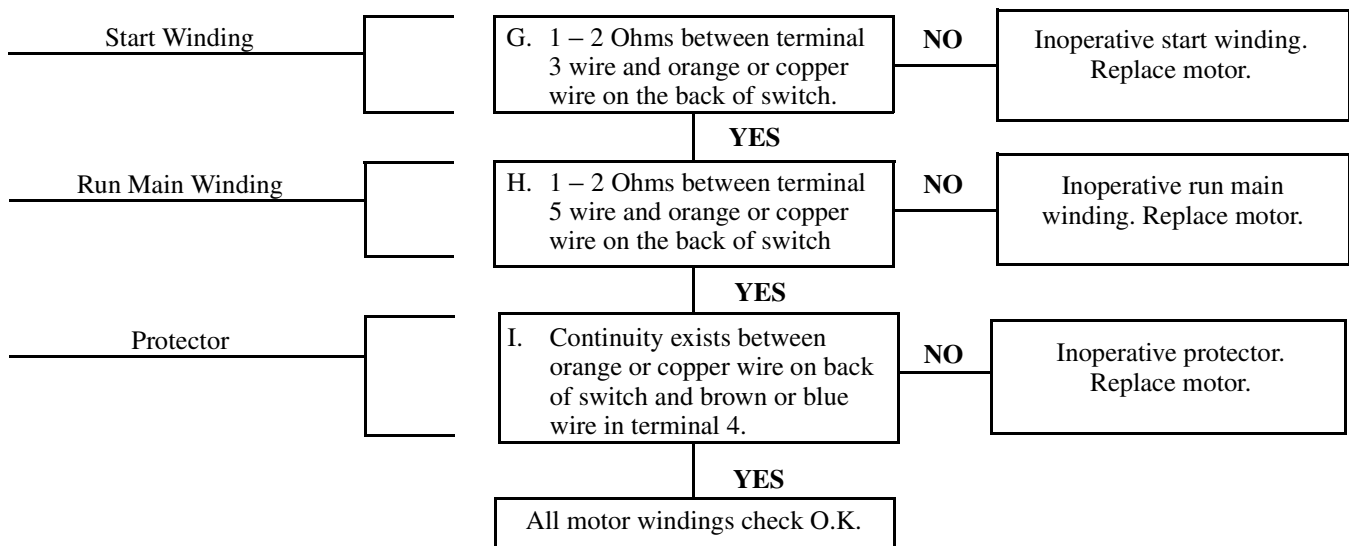



WARNING

To reduce the risk of electric shock, fire, explosion, serious injury or death:

- Disconnect all electric power to the machine and accessories before servicing.
- Close gas shut-off valve to gas dryer before servicing.
- Never start machine with any guards/panels removed.
- Whenever ground wires are removed during servicing, these ground wires must be reconnected to ensure that the machine is properly grounded.
- Washer motor not grounded! Disconnect electric power before servicing motor.

W502

53. Motor Switch

- a. Remove motor and exhaust fan assembly.
- b. Remove the two motor switch attaching screws. Refer to *Figure 38*. Disconnect switch leads. Remove motor switch.
- c. Remove thermal overload protector

NOTE: The thermal overload protector is unique to the motor from which it was removed and should only be used on that motor. To reduce the risk of overheating the motor, do not use any thermal overload protector other than the one taken from the inoperative motor switch in step 3.

(1) Motor with Switch on Blower End

Using a small bladed screwdriver, press the thermal overload protector mounting tab downward and remove the thermal overload protector from the inoperative motor switch. Refer to *Figure 33*.

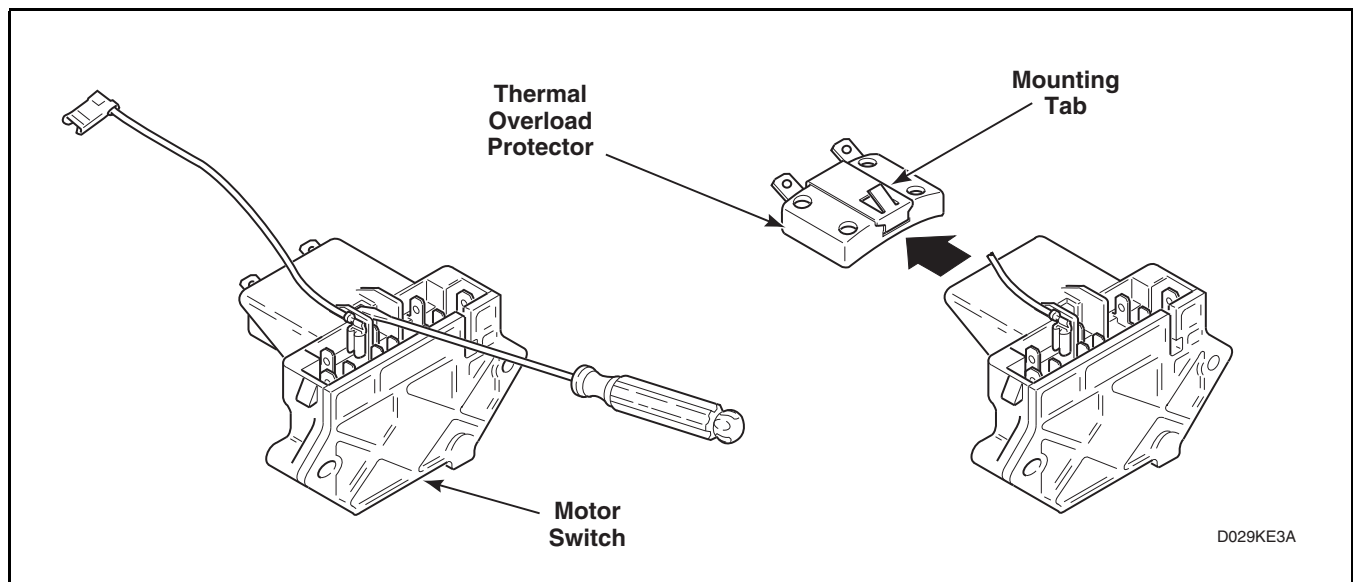

Figure 33



WARNING

To reduce the risk of electric shock, fire, explosion, serious injury or death:

- Disconnect all electric power to the machine and accessories before servicing.
- Close gas shut-off valve to gas dryer before servicing.
- Never start machine with any guards/panels removed.
- Whenever ground wires are removed during servicing, these ground wires must be reconnected to ensure that the machine is properly grounded.
- Washer motor not grounded! Disconnect electric power before servicing motor.

W502

(2) Motor with switch on pulley end

Press the tip of a small bladed screwdriver into the slot located between top of motor switch and plastic clip. Lift up on handle of screwdriver until both clip and thermal overload protector detach from motor switch. Refer to *Figure 34*.

- d. Attach the thermal overload protector removed in Step “c” to the new motor switch.
- e. Install new motor switch onto motor and reconnect motor switch leads removed in Step “b”. Refer to *Figure 38*.

- f. Test motor switch by following the step-by-step procedures included in *Paragraph 52*.
- g. Before reinstalling the motor assembly, apply power (120, 208 or 240 VAC – refer to machine serial plate) directly to motor terminals 4 and 5. Then start and run the motor at least 6 times, making sure the motor and switch are operating properly.

NOTE: The dryer manufacturer and parts suppliers are not liable for improper switch installation.

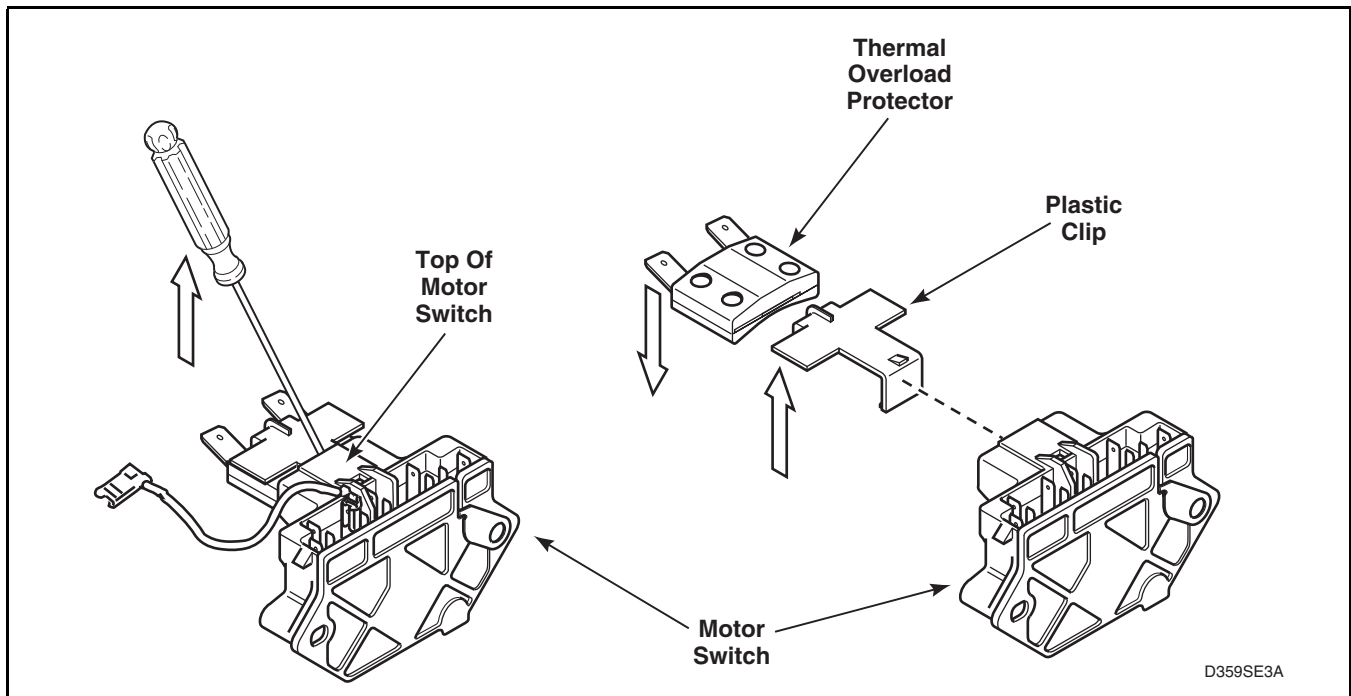

Figure 34



WARNING

To reduce the risk of electric shock, fire, explosion, serious injury or death:

- Disconnect all electric power to the machine and accessories before servicing.
- Close gas shut-off valve to gas dryer before servicing.
- Never start machine with any guards/panels removed.
- Whenever ground wires are removed during servicing, these ground wires must be reconnected to ensure that the machine is properly grounded.
- Washer motor not grounded! Disconnect electric power before servicing motor.

W502

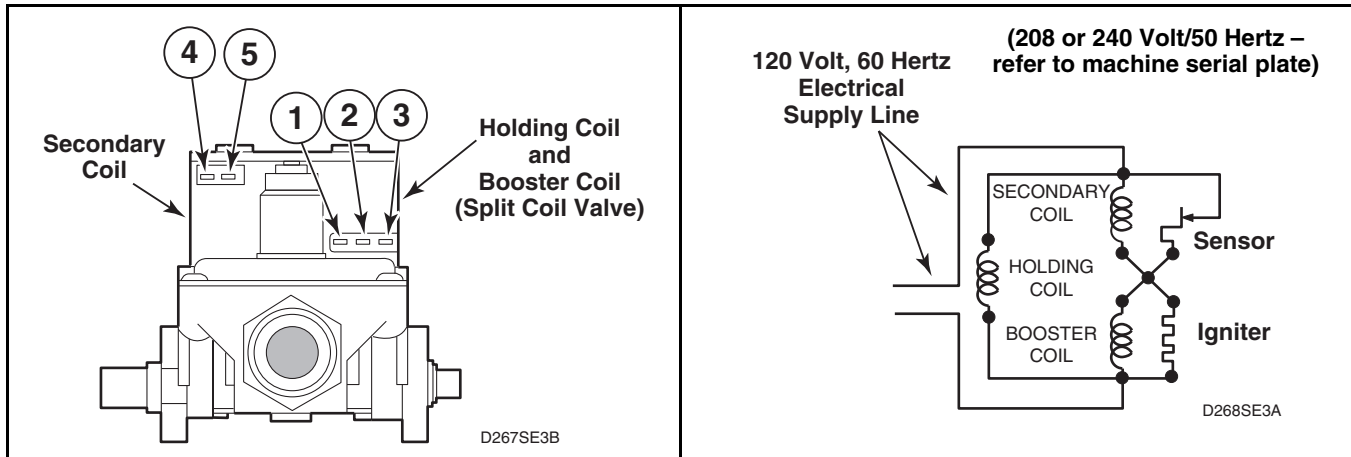

Figure 35

54. Burner System Operation

(Gas Models – Refer to *Figure 35*.)

a. Components

This burner has four basic components: a silicon carbide (glow bar) igniter, burner tube, sensor, and a two-stage gas valve consisting of a split-coil valve and a secondary coil valve. The split-coil valve is opened when the dryer thermostat calls for heat, while the secondary valve does not open until the igniter has attained ignition temperature.

b. Pre-Ignition Circuits

When the dryer thermostat calls for heat, circuits are completed through the holding coil, sensor, booster coil and igniter. Both coils must be energized to open the split-coil valve. Once opened, the holding coil can hold the valve open without assistance from the booster coil. The sensor triggers the current to travel around the secondary coil and through the igniter, causing the igniter to get hot.

c. Burner Circuit

In approximately 30 seconds, the igniter attains ignition temperature and ignition is made. The heat from the burner flame causes the sensor contacts (located on burner housing

beside the igniter) to open. A circuit is then completed through the secondary valve coil, opening the valve and allowing gas to flow.

d. Momentary Power Interruption

Upon resumption of power, sensor contacts will still be open, permitting secondary valve to open. However, with the secondary coil in the circuit, the booster coil cannot draw enough current to open the split-coil valve. When sensor contacts do reclose, the secondary valve will close, and the burner system will be in the normal pre-ignition circuit.

e. Flame Failure

In case of flame failure, the sensor contacts will re-close in about 45 seconds. This will close the secondary valve and the burner system will be in the normal pre-ignition circuit.

f. Ignition Failure

If flame is not established as sensor contacts open, secondary valve will remain open until sensor contacts re-close. Sensor will continue to recycle the igniter and secondary valve (about once per minute) until ignition is made or dryer is turned off.



WARNING

- To reduce the risk of electric shock, fire, explosion, serious injury or death:
- Disconnect all electric power to the machine and accessories before servicing.
 - Close gas shut-off valve to gas dryer before servicing.
 - Never start machine with any guards/panels removed.
 - Whenever ground wires are removed during servicing, these ground wires must be reconnected to ensure that the machine is properly grounded.
 - Washer motor not grounded! Disconnect electric power before servicing motor.

W502

55. Electrical Circuit To Ignition System (Gas Models)

- a. While supporting the access panel, remove two screws from bottom edge of access panel.
- b. Gently lower the access panel to disengage locators from bottom edge of front panel.
- c. Close main gas shut-off valve. Refer to *Figure 18*.
- d. Remove valve wire harness disconnect block from the holding and booster coil. Refer to *Figure 36*.
- e. Plug dryer power cord into wall receptacle, and start the dryer in a heat setting (refer to the Operating Instructions supplied with dryer).
- f. Set test meter to read AC voltage and apply meter probes into terminals on the dryer harness plug that would correspond to terminals "1" and "2" on the coil. *Figure 35*. Meter should register line voltage in all Fabric settings, except FLUFF which should read "zero" VAC.
- g. If meter does not read line voltage in step "f", check motor switch, thermostats, fabric switch, accumulator, or timer.

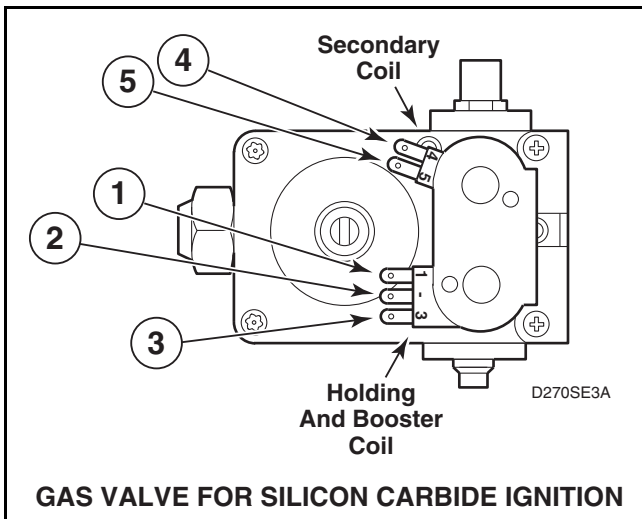

Figure 36



WARNING

To reduce the risk of fire, explosion and electric shock, close the valve in the gas supply line to the gas dryer and disconnect the electrical power unless gas or power supplies are required to perform test procedure.

W263

56. Gas Valve Coils Check (Gas Models)

- a. While supporting the access panel, remove two screws from bottom edge of access panel.
- b. Gently lower the access panel to disengage locators from bottom edge of front panel.
- c. Close main gas shut-off valve. Refer to *Figure 18*.
- d. Remove disconnect blocks from gas valve coils.
- e. Set test meter to read Ohms and put meter probes to terminals shown in *Figure 36*, and in the following chart.

COIL TOLERANCE READINGS

Meter probes to terminals:	Meter should read:
Holding Coil – Terminals 1 & 2	1365 ± 25 Ohms
Booster Coil – Terminals 1 & 3	560 ± 25 Ohms
Secondary Coil – Terminals 4 & 5	1220 ± 50 Ohms

NOTE: If meter registers any other readings than those listed above, the respective coil(s) should be replaced.



WARNING

To reduce the risk of electric shock, fire, explosion, serious injury or death:

- Disconnect all electric power to the machine and accessories before servicing.
- Close gas shut-off valve to gas dryer before servicing.
- Never start machine with any guards/panels removed.
- Whenever ground wires are removed during servicing, these ground wires must be reconnected to ensure that the machine is properly grounded.
- Washer motor not grounded! Disconnect electric power before servicing motor.

W502

57. Sensor Check (Gas Models)

- a. While supporting the access panel, remove two screws from bottom edge of access panel.
- b. Gently lower the access panel to disengage locators from bottom edge of front panel.
- c. Close main gas shut-off valve. Refer to *Figure 18*.
- d. Remove wires from sensor terminals.
- e. Set test meter to read Ohms and put meter probes on sensor terminals. Meter should read “zero” Ohms. If meter registers an Ohm reading of any amount, replace sensor.

58. Igniter Check (Gas Models)

- a. While supporting the access panel, remove two screws from bottom edge of access panel.
- b. Gently lower the access panel to disengage locators from bottom edge of front panel.
- c. Close main gas shut-off valve. Refer to *Figure 18*.
- d. Disconnect igniter wires at disconnect block.
- e. Set test meter to read Ohms and put meter probes on terminals of igniter wires.
- f. **Silicon Carbide Igniter** – meter should read between 45 – 200 Ohms. Refer to *Figure 37*.

NOTE: If meter does not read appropriate Ohms, then replace the igniter.

IMPORTANT: Always examine all wires, terminals and connectors to be sure wiring is correct before replacing any components.

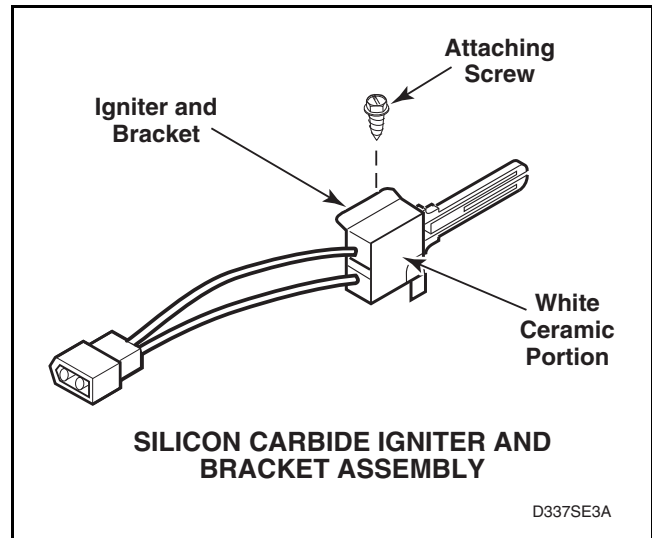

Figure 37



WARNING

To reduce the risk of electric shock, fire, explosion, serious injury or death:

- Disconnect all electric power to the machine and accessories before servicing.
- Close gas shut-off valve to gas dryer before servicing.
- Never start machine with any guards/panels removed.
- Whenever ground wires are removed during servicing, these ground wires must be reconnected to ensure that the machine is properly grounded.
- Washer motor not grounded! Disconnect electric power before servicing motor.

W502

59. Thermal Fuse (Electric Models)

- a. While supporting the access panel, remove two screws from bottom edge of front access panel.
- b. Gently lower the access panel to disengage panel locators from bottom edge of front panel.
- c. Label and disconnect wires from thermal fuse.

NOTE: Refer to wiring diagram when rewiring thermal fuse.

- d. Set multimeter to read Ohms. Apply meter probes to thermal fuse terminals. Multimeter should read 0 Ohms. If the meter does not show any reading (infinite Ohms), then the fuse is open. If the fuse is open, then replace BOTH the thermal fuse and the limit thermostat.

60. Heater Assembly (Electric Models)

- a. While supporting the access panel, remove two screws from bottom edge of access panel.
- b. Gently lower the access panel to disengage panel locators from bottom edge of front panel.
- c. Disconnect wires from heater assembly.

NOTE: Refer to wiring diagram when rewiring heater assembly.

- d. Set meter to read Ohms. Apply meter probes to the heater assembly terminals. Meter should read as follows: (Cold Ohms).

Element Color Code	KW	Voltage/Hz.	Resistance Reading
Red	5	240 V 60 Hz.	10.39 ± .31 Ohms Cold
White	4.75	208 V 60 Hz.	8.2 ± .5 Ohms Cold
Green	4.8	240 V 50 Hz.	10.75 ± .32 Ohms Cold
Yellow	4	240 V 50 Hz.	13.03 ± .39 Ohms Cold
Blue	3.1	240 V 50 Hz.	16.7 ± .5 Ohms Cold
Orange	5.35	240 V 60 Hz.	9.72 ± .3 Ohms Cold
Purple	4.25	208 V 60 Hz.	9.27 ± .3 Ohms Cold

61. Cycling or Limit Thermostat

- a. While supporting the access panel, remove two screws from bottom edge of access panel.
- b. Gently lower the access panel to disengage panel locators from bottom edge of front panel.
- c. Label and disconnect wires from thermostat.

NOTE: Refer to wiring diagram when rewiring thermostat.

Cycling Thermostat (S.P.S.T. – 2 Terminals) or Limit Thermostat

- d. Set meter to read Ohms.
 - (1) Apply meter probes to the thermostat terminals.
 - (2) Meter should read “zero.”



WARNING

To reduce the risk of electric shock, fire, explosion, serious injury or death:

- Disconnect all electric power to the machine and accessories before servicing.
- Close gas shut-off valve to gas dryer before servicing.
- Never start machine with any guards/panels removed.
- Whenever ground wires are removed during servicing, these ground wires must be reconnected to ensure that the machine is properly grounded.
- Washer motor not grounded! Disconnect electric power before servicing motor.

W502

62. Door Switch

- a. While supporting the access panel, remove two screws from bottom edge of access panel.
- b. Gently lower the access panel to disengage locators from bottom edge of front panel.
- c. Remove two screws holding bottom tabs on front panel to dryer side panels. Swing bottom of front panel away from dryer far enough to disengage hold-down clips and locators from cabinet top.
- d. Disconnect wires from door switch.

NOTE: Refer to model wiring diagram when rewiring door switch.

- e. Set meter to read Ohms and apply meter probes on switch terminals 1 and 3 with door closed. You should get “zero” reading.
- f. Apply probes to terminals 1 and 2 with door closed. The meter should read “infinite”.
- g. Open door. Meter should read “infinite” between 1 and 3 and “zero” between 1 and 2.

Section 9

Internal Wiring of Dryer Motor Switch



WARNING

To reduce the risk of electric shock, fire, explosion, serious injury or death:

- Disconnect all electric power to the machine and accessories before servicing.
- Close gas shut-off valve to gas dryer before servicing.
- Never start machine with any guards/panels removed.
- Whenever ground wires are removed during servicing, these ground wires must be reconnected to ensure that the machine is properly grounded.
- Washer motor not grounded! Disconnect electric power before servicing motor.

W502

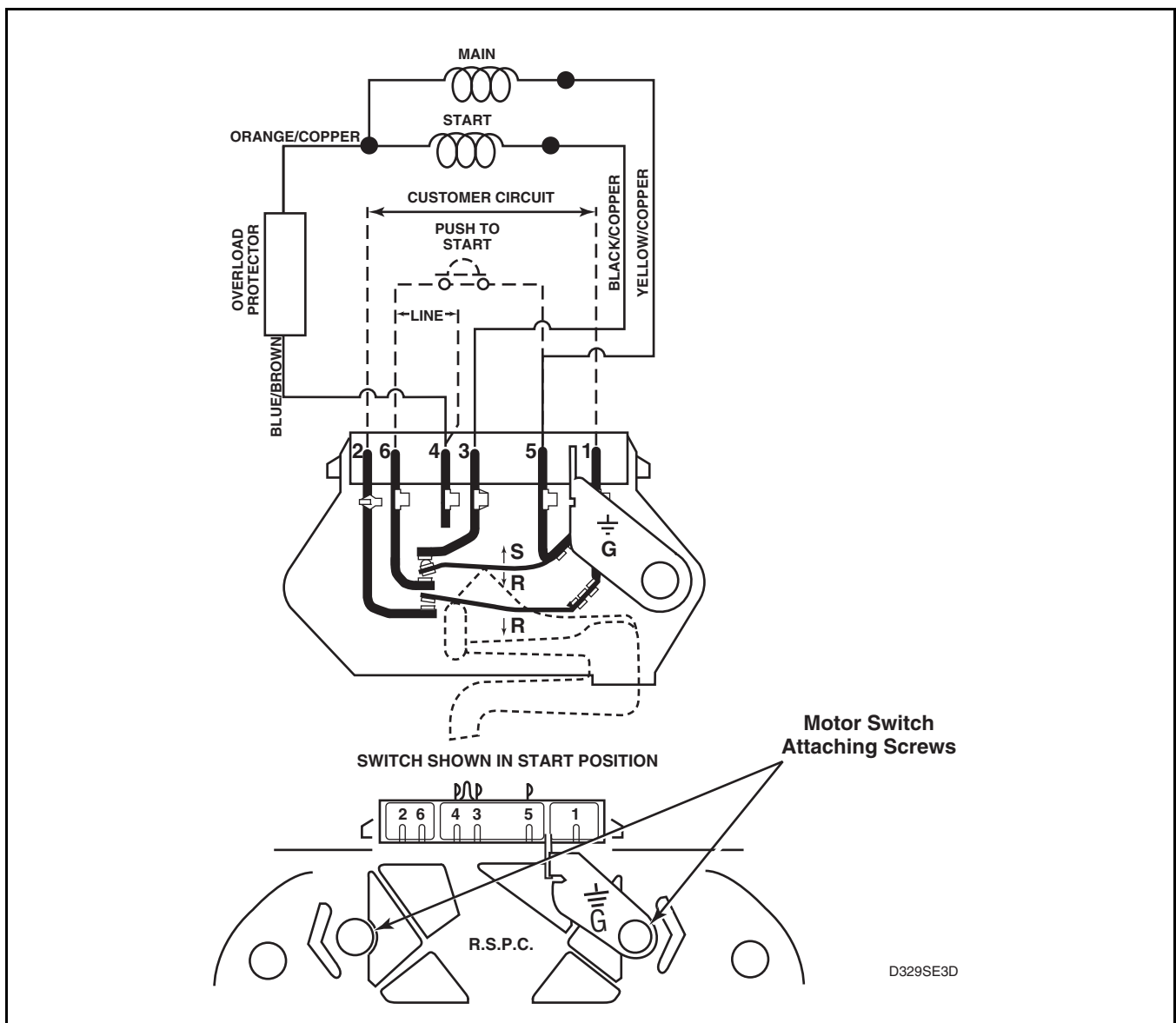

Figure 38