



HuebschOriginators

**Service Manual
for
Commercial
Superload II
Washer-
Extractors**

(Metered and Nonmetered)

See Page 3 for Model Numbers

Huebsch Originators
Box 990
Hall Street
Ripon, Wisconsin 54971-0990

Part No. 82093
3/95

▲ WARNING

Failure to install, maintain, and/or operate this product according to the manufacturer's instructions may result in conditions which can produce serious injury, death and/or property damage.

Do not repair or replace any part of the product or attempt any servicing unless specifically recommended or published in this Service Manual and that you understand and have the skills to carry out.

Whenever ground wires are removed during servicing, these ground wires must be reconnected to ensure that the product is properly grounded and to reduce the risk of fire, electric shock, serious injury, or death.

W006R1

▲ WARNING

Repairs that are made to your products by unqualified persons can result in hazards due to improper assembly to adjustments subjecting you, or the inexperienced person making such repairs, to the risk of serious injury, electrical shock, or death.

W007

▲ CAUTION

If you or an unqualified person perform service on your product, you must assume the responsibility for any personal injury or property damage which may result. The manufacturer will not be responsible for any injury or property damage arising from improper service and/or service procedures.

W008

NOTE: The WARNINGS and IMPORTANT STICKERS appearing in this manual are not meant to cover all possible conditions and situations that may occur. It must be understood that common sense, caution and carefulness are factors which CANNOT be built into these tumblers. These factors MUST BE supplied by the person(s) installing, maintaining, or operating the tumbler.

Always contact your dealer, distributor, service agent or the manufacturer about any problem or conditions you do not understand.

Recognize Safety Symbols, Words and Labels

▲ DANGER -- Immediate hazards which WILL result in serious injury or death.

▲ WARNING -- Hazards or unsafe practices which COULD result in serious injury or death.

▲ CAUTION -- Hazards or unsafe practices which COULD result in minor or moderate injury or product or property damage.

W009

Table of Contents

Model Identification	3
Nameplate Location	3

SECTION I Service Procedures

1. Start Switch	4
2. Accumulator Coin Drop	4
3. Control Panel Assembly	6
4. Lower Front Panel	9
5. Pivot Arm and Handle	10
6. Loading Door Assembly	10
7. Door Glass and Gasket	11
8. Cabinet Top Assembly	13
9. Coin Vault	14
10. Front Panel Assembly	14
11. Door Hinge	17
12. Door Lock Assembly	18
13. Door Lock Components	18
14. Door Seal	21
15. Button Trap	22
16. Drain Valve and Bracket Assembly	23
17. Terminal Block	25
18. Pressure Switch	25
19. Motor Relay	26
20. Timer Assembly	27
21. Capacitor	28
22. Mixing Valve	28
23. Water Inlet	30
24. Water Inlet-To-Tub Hose	30
25. Overflow Hose	31
26. Cross Channel Assembly	32
27. Drive Motor and Mounting Bracket	33
28. Drive Motor	34
29. No. 355P3 Clutch Repair Kit	34
30. Pump Assembly	35
31. Pulley and Hub Assembly	36
32. Cylinder Assembly	37
33. Rear Tub Head	39
34. Water Seals	40
35. Cylinder Shaft Bearing	41

SECTION II Adjustments

36. Drive Belt	43
37. Pressure Switch	44
38. Door Lock Assembly	45

SECTION III Test Procedures

39. Start Switch	49
40. Indicator Lights	50
41. Wash Temperature Switch	51
42. Action Switch	51
43. Door Lock Assembly	52
44. Pressure Switch	52
45. Motor Relay	53
46. Capacitor	54
47. Cycle Timer	55
48. Reversing Timer	56
49. Timer Motor	57
50. Mixing Valve Solenoid	57
51. Pump Motor	58
52. Drive Motor	58

SECTION IV Service Helps

53. Washer Does Not Start	59
54. Cylinder Does Not Fill	59
55. No Hot Water	60
56. No Cold Water	60
57. No Warm Water	60
58. Water Does Not Shut-Off	61
59. Water Does Not Drain From Cylinder	61
60. Drive Motor Does Not Run	62
61. Motor Overload Protector Cycles Repeatedly	62
62. Cylinder Does Not Turn	63
62. Cycle Timer Does Not Advance	63
Timer Cycle Sequence	64

SECTION V Rinse Water Options

SECTION VI Wiring Schematics

SECTION VII Wiring Diagrams

Model identification

Information in this manual is applicable to the following Superload II Washer-Extractor Models .

MODELS		DRAIN	
Metered	Nonmetered	Pump	Nonpump
HL9151 or HL9161	HL9171		X
HL9153 or HL9163	HL9173	X	

Nameplate Location

When writing for information on the Superload II Washer-Extractor, be sure to mention model and serial numbers. The model and serial numbers will be found on the nameplate as shown.

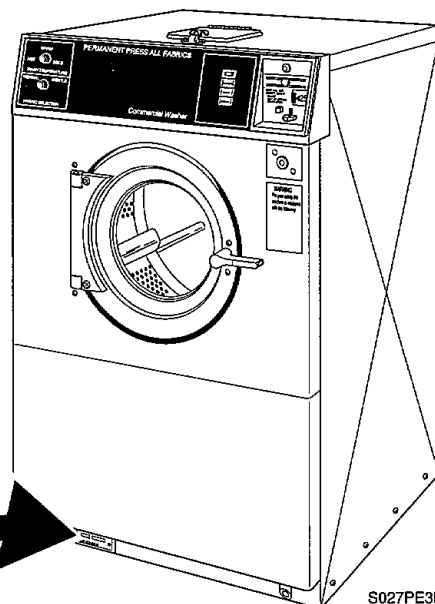

IMPORTANT: When checking clutch operation, a momentary slipping noise may be heard when the motor drive goes into the spin mode. This is normal operation caused by the drive clutch pads engaging against the clutch drum.

To avoid serious damage to motor drive or timers, **DO NOT** advance either timer with power on, or with the wash cylinder moving.

It is very important to keep timers synchronized. Timers automatically synchronize themselves (if needed) during each spin cycle.

If timers are advanced or changed in any way to service, the service man (with power off and clothes cylinder stopped) should put the washer into the final spin cycle and allow the washer to complete the cycle by itself. This will get the timers synchronized and the washer set for proper operation.

If the washer timers advance from tumble into spin in the wrong rotation, the clothes cylinder will also spin in the wrong rotation, but the timers will automatically synchronize during that spin cycle. Correct rotation viewing clothes cylinder from the front of washer is clockwise; **BOTH FOR LAST TUMBLE MODE BEFORE SPIN AND SPIN.**

SECTION I

Service Procedures

▲ WARNING

To reduce the risk of electric shock, fire, explosion, serious injury or death:

- Disconnect electric power to the washer before servicing.
- Never start the washer with any guards/panels removed.
- Whenever ground wires are removed during servicing, these ground wires must be reconnected to ensure that the washer is properly grounded.

W003

IMPORTANT: When reference to directions (right or left) in this manual, it is from the operator's position facing the front of the washer.

NOTE: Refer to *Figure 3* for accumulator coin drop assembly sequence.

1. START SWITCH — Nonmetered Models (Refer to *Figure 1*)

- Remove hex head screw and pull start switch out of washer as far as wires will permit
- Disconnect wire harness at disconnect block.
- Remove two screws and nuts holding switch to plate and frame.

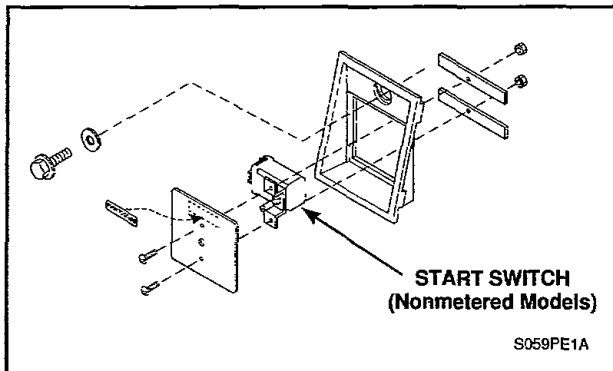

Figure 1

2. ACCUMULATOR COIN DROP — Metered Models (Refer to *Figure 2*)

- Unlock coin drop and pull out of washer as far as wires will permit.

NOTE: Lock is threaded and will require several counterclockwise turns to unlock.

- Disconnect wire harness at disconnect block.

IMPORTANT STEPS IN RE-ASSEMBLING ACCUMULATOR COIN DROP

- Install coin switch, *Figure 3*, so switch "clicks" before coin has completely dropped free of actuator arm. When actuator arm returns to natural position, there should be some free travel between the "click" and reseating against bottom of coin chute.



Figure 2

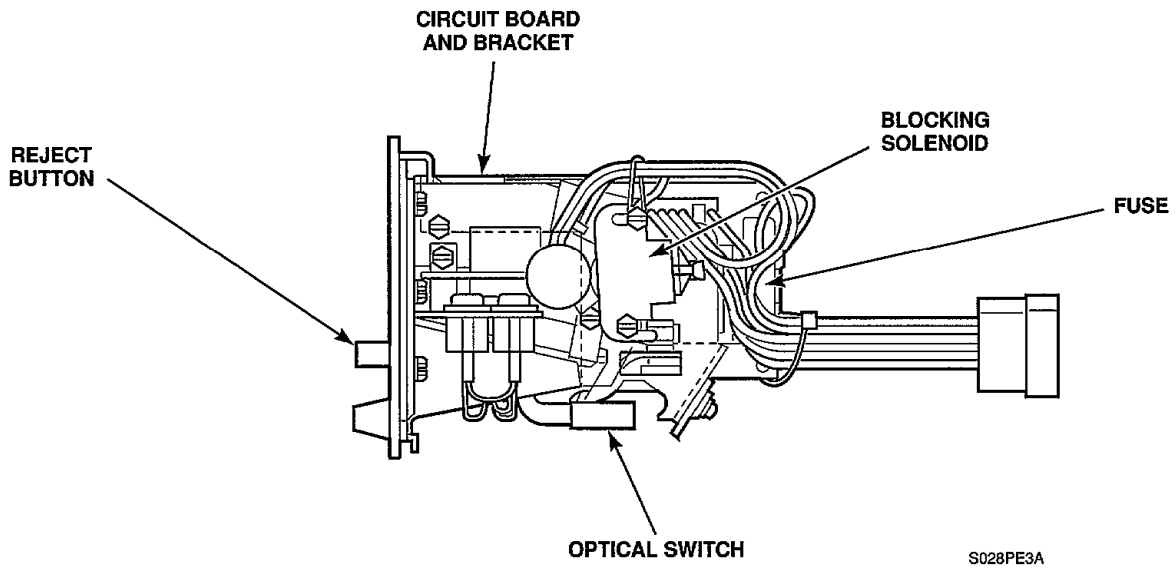

**ACCUMULATOR COIN DROP (Digital)
(Models HL9151 and HL9153)**

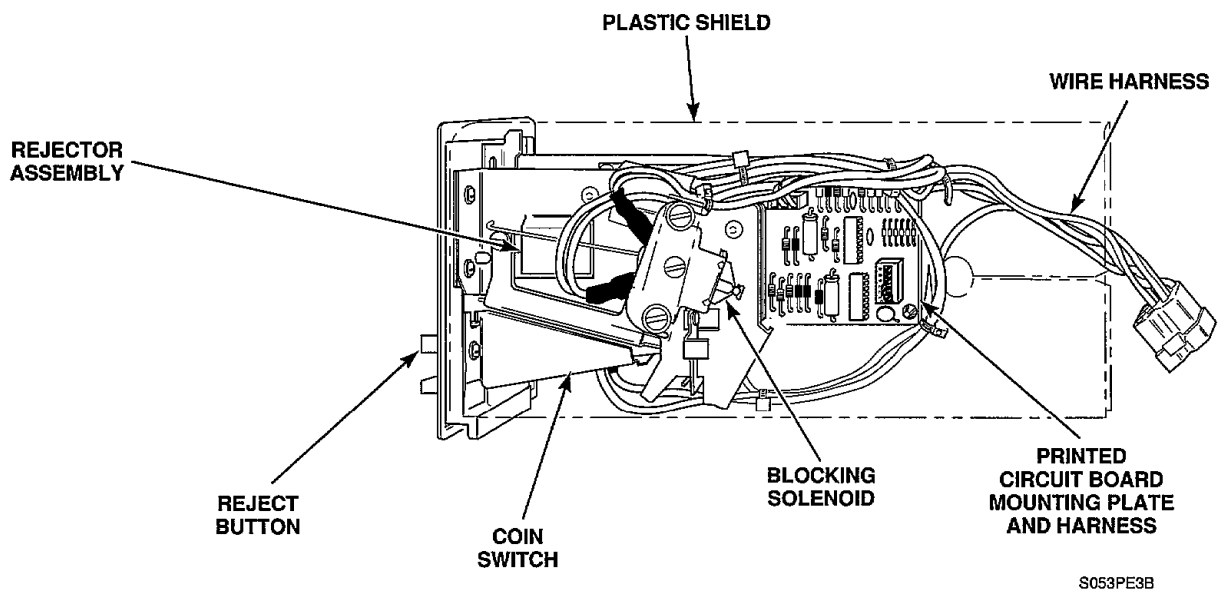

**ACCUMULATOR COIN DROP (Non-Digital)
(Models HL9161 and HL9163)**

Figure 3

▲ WARNING

To reduce the risk of electric shock, fire, explosion, serious injury or death:

- Disconnect electric power to the washer before servicing.
- Never start the washer with any guards/panels removed.
- Whenever ground wires are removed during servicing, these ground wires must be reconnected to ensure that the washer is properly grounded.

W003

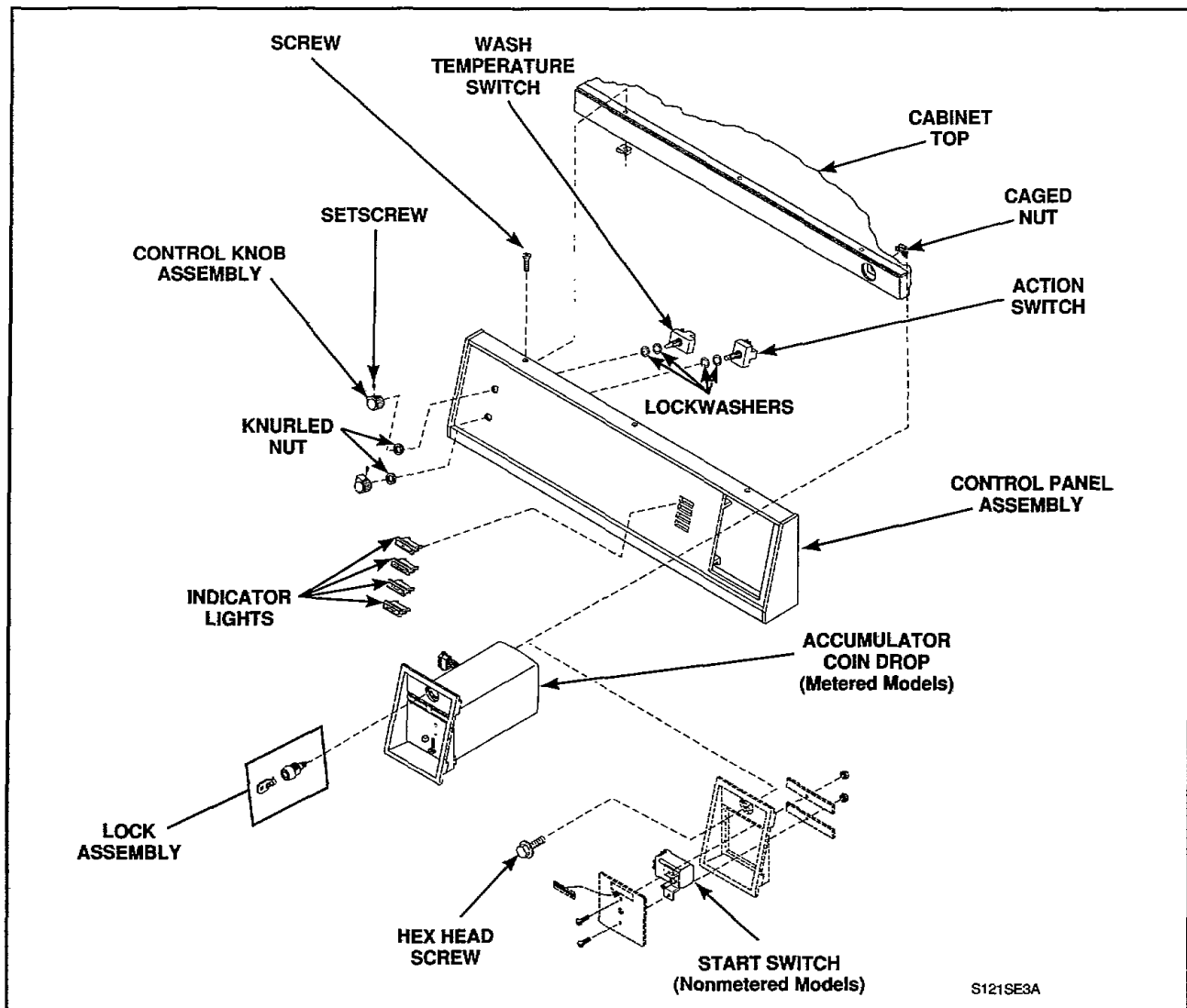

S121SE3A

Figure 4

3. CONTROL PANEL ASSEMBLY

- a. **METERED MODELS** — Unlock accumulator coin drop and pull out of washer as far as wires will permit, *Figure 4*.

NOTE: Lock is threaded and will require several counterclockwise turns to unlock.

NONMETERED MODELS — Remove the hex head screw and pull start switch out of washer as far as wires will permit, *Figure 4*.

- b. Disconnect the coin drop or start switch wire harness at the quick disconnect blocks.
- c. Remove the three screws holding control panel assembly to cabinet top, *Figure 4*.
- d. Tilt control panel assembly away from washer and disconnect wire harness at disconnect blocks, then remove control panel assembly.

▲ WARNING

To reduce the risk of electric shock, fire, explosion, serious injury or death:

- Disconnect electric power to the washer before servicing.
- Never start the washer with any guards/panels removed.
- Whenever ground wires are removed during servicing, these ground wires must be reconnected to ensure that the washer is properly grounded.

W003

- e. Disconnect wires from each indicator light, compress the locking tabs and push each light out through front of control panel, *Figure 4*.

NOTE: Refer to wiring diagram when rewiring lights.

- f. Disconnect wires from the temperature and action switches.

NOTE: Refer to wiring diagram when rewiring switches.

- g. Loosen setscrew holding switch knobs to the switch shafts and remove knobs, *Figure 4*.
- h. Remove knurled nuts holding switches to the control panel assembly and remove switches, *Figure 4*.

IMPORTANT: When reinstalling switch, two lockwashers must be between each switch and the backside of the control panel for grounding purposes, *Figure 4*.

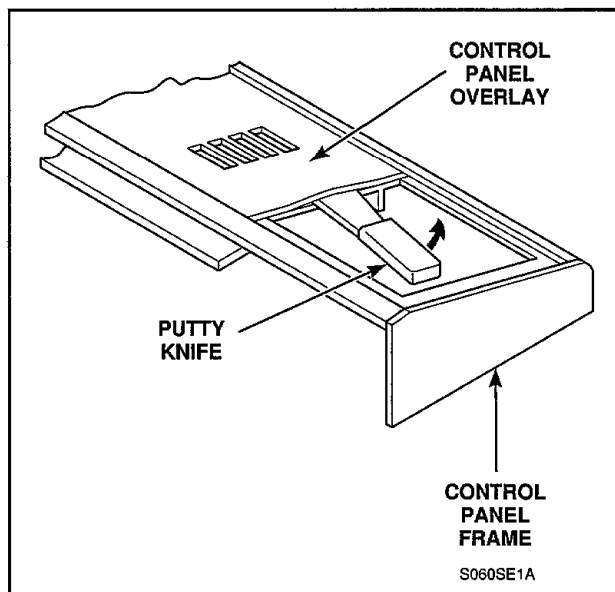

GRAPHIC PANEL REPLACEMENT

- a. Lay control panel assembly on flat surface with panel facing upward.
- b. Starting at the center of the panel opening, insert putty knife between overlay and panel frame, *Figure 5*. Lift up on putty knife and peel old control panel overlay off the control panel frame. Then remove the narrow piece of overlay from the right side of the panel.
- c. Remove the narrow strip of overlay from the new panel. Remove ONLY the center strip of protective backing, leave the two end pieces in place.
- d. Bow the narrow strip just enough to allow getting the ends of the strip into the top and bottom grooves of the panel frame, *Figure 6*.
- e. Remove the center backing strip from the large panel overlay, leaving the two edge strips in place.

IMPORTANT: The panel overlay must be positioned correctly on the control panel frame on the first try because once it is down on the panel frame it cannot be moved without being damaged.

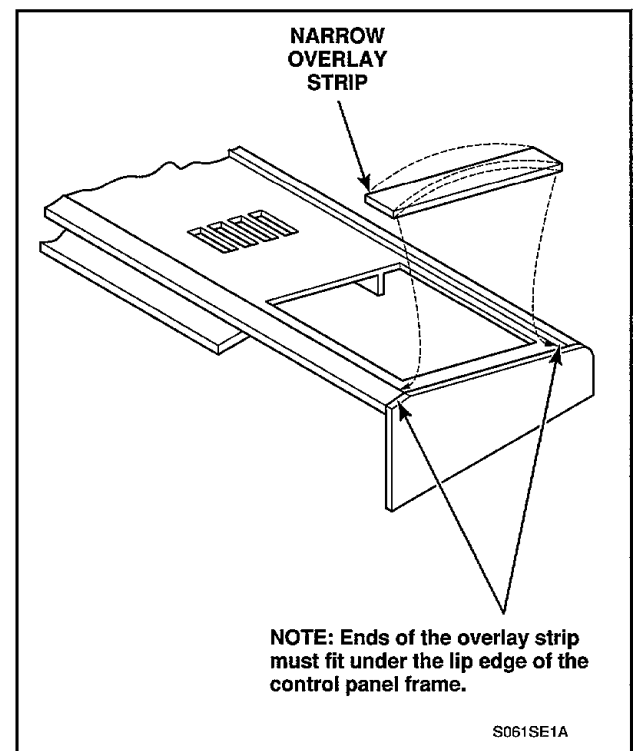

▲ WARNING

To reduce the risk of electric shock, fire, explosion, serious injury or death:

- Disconnect electric power to the washer before servicing.
- Never start the washer with any guards/panels removed.
- Whenever ground wires are removed during servicing, these ground wires must be reconnected to ensure that the washer is properly grounded.

W003

- Set control panel frame upward, place the bottom edge of the panel overlay into the bottom groove of the panel frame, *Figure 7*. Butt the left end of the overlay against the left end frame of the panel frame.
- While holding the bottom edge in place, carefully bow the center of the panel overlay just enough to allow the top edge of the panel overlay to fit into the top groove of the panel frame. Then firmly press the center of the overlay onto the panel frame.
- Reassemble controls onto control panel, *Figure 4*.

NOTE: Refer to wiring diagram and rewire the control panel components.

- Reconnect wire harness at the disconnect blocks and reinstall the control panel assembly onto washer.
- Reinstall the coin drop or start switch into the control panel opening.
- Reconnect the electrical power to the washer.

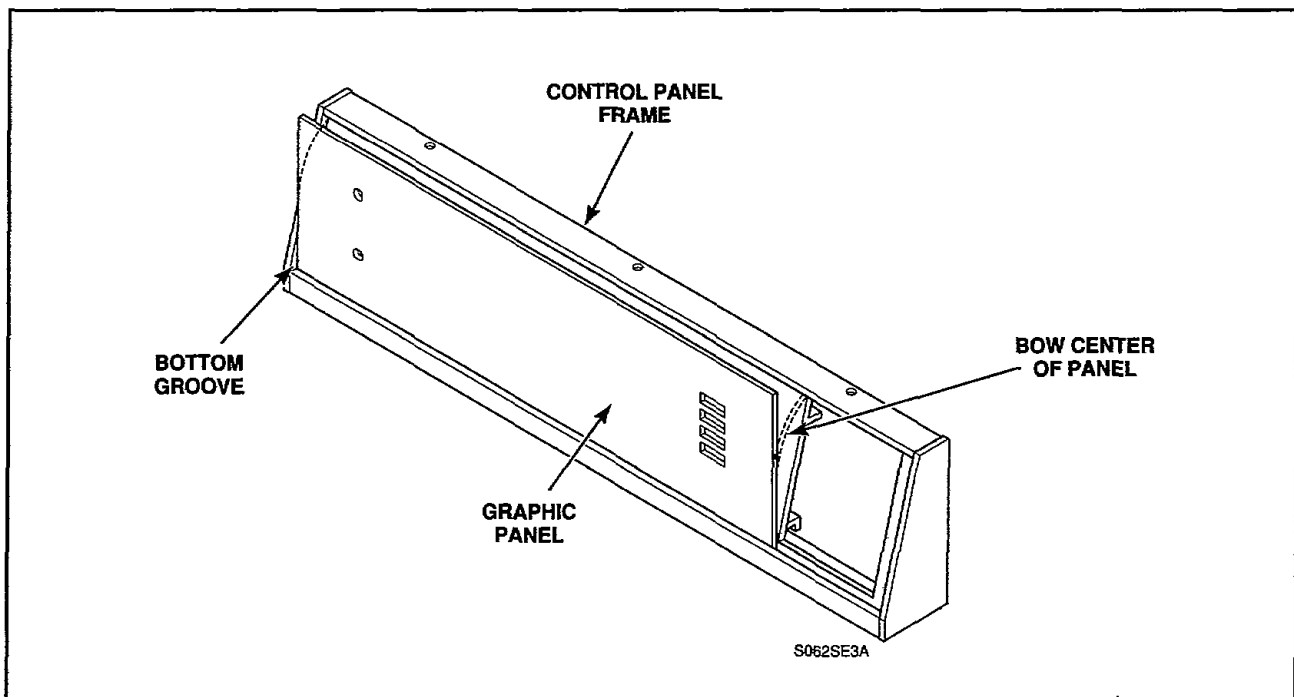

Figure 7

▲ WARNING

To reduce the risk of electric shock, fire, explosion, serious injury or death:

- Disconnect electric power to the washer before servicing.
- Never start the washer with any guards/panels removed.
- Whenever ground wires are removed during servicing, these ground wires must be reconnected to ensure that the washer is properly grounded.

W003

4. LOWER FRONT PANEL (Figure 8)

- Remove four screws holding lower front panel to washer base.
- Pull bottom of panel away from washer, lower the panel, then remove from washer.

NOTE: PUMP MODELS — When reinstalling the lower front panel, end of the overflow hose must protrude through hole in bottom of panel.

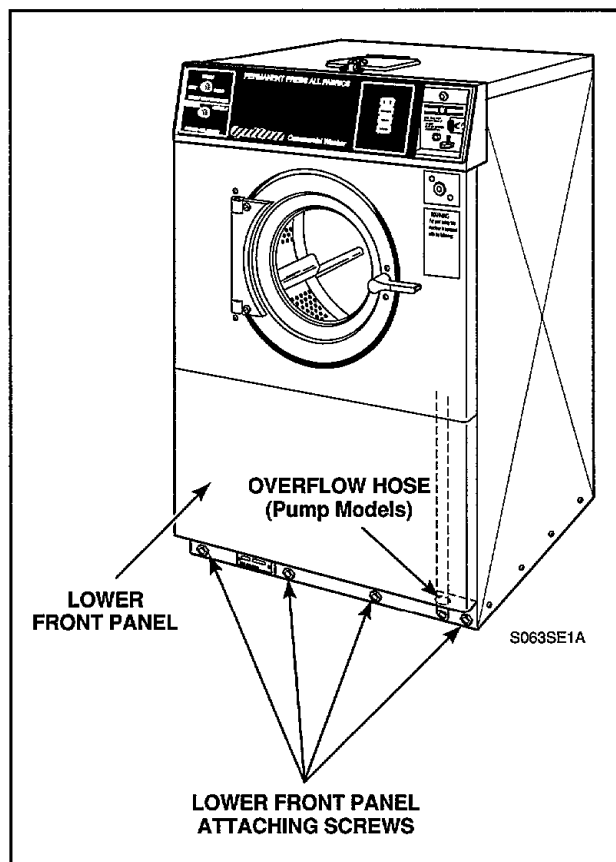

Figure 8

▲ WARNING

To reduce the risk of electric shock, fire, explosion, serious injury or death:

- Disconnect electric power to the washer before servicing.
- Never start the washer with any guards/panels removed.
- Whenever ground wires are removed during servicing, these ground wires must be reconnected to ensure that the washer is properly grounded.

W003

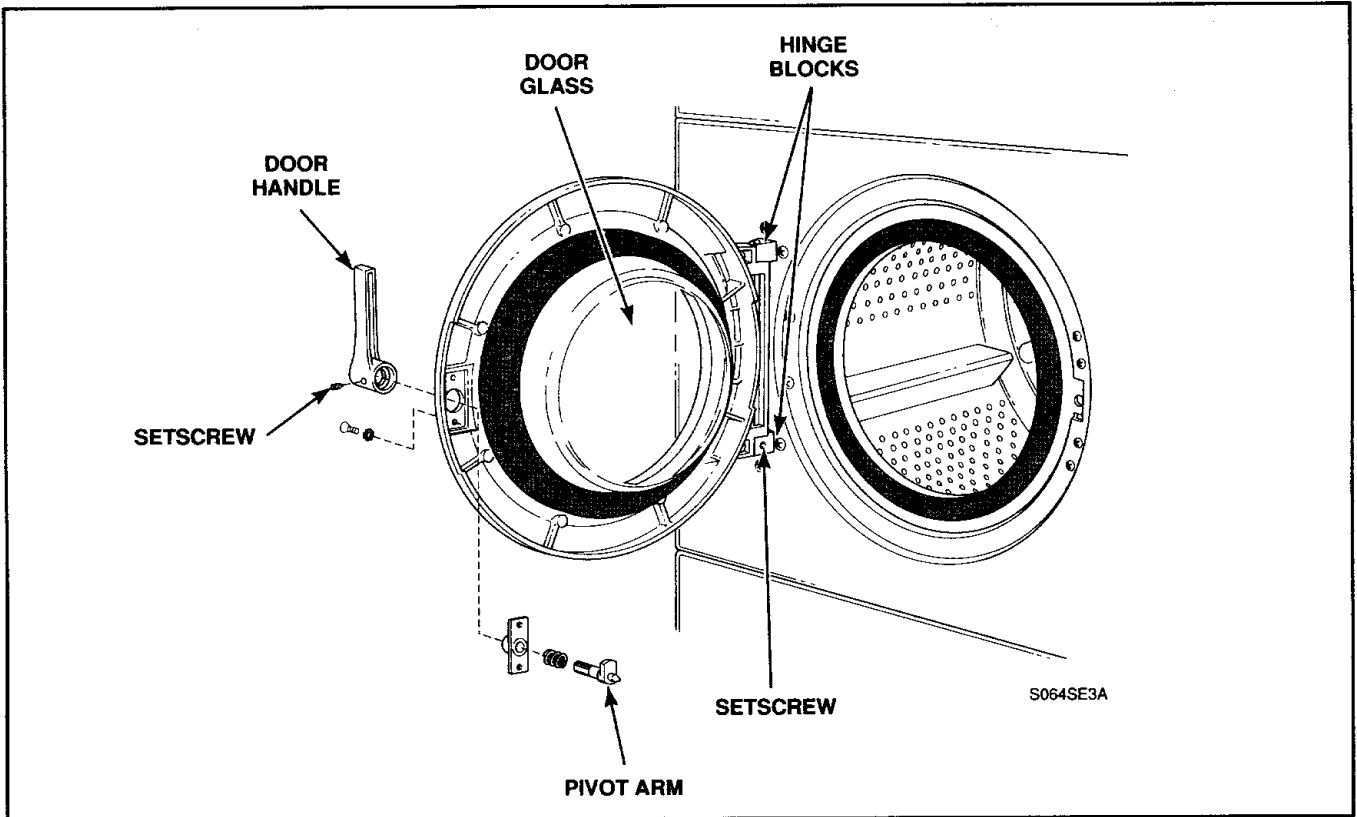

Figure 9

5. PIVOT ARM AND HANDLE (Refer to *Figure 9*)

- Open loading door.
- Loosen setscrew in door handle and turn pivot arm out of handle.

NOTE: When reinstalling, turn pivot arm into door handle until door fits snug when closed and latched. With pivot arm parallel to door handle, tighten setscrew securely. (Apply a retaining compound such as Loctite on setscrew threads).

6. LOADING DOOR ASSEMBLY (Refer to *Figure 9*)

Open loading door, loosen setscrew in lower hinge block, support door and remove hinge pin.

NOTE: Spacer washer(s) must be located on hinge pin on lower hinge block when installing door.

▲ WARNING

To reduce the risk of electric shock, fire, explosion, serious injury or death:

- Disconnect electric power to the washer before servicing.
- Never start the washer with any guards/panels removed.
- Whenever ground wires are removed during servicing, these ground wires must be reconnected to ensure that the washer is properly grounded.

W003

7. DOOR GLASS AND GASKET

- Open loading door.

NOTE: The door glass and gasket must be removed together.

- Starting at the top of the door, peel the old gasket from the door frame and at the same time push in on the door glass forcing the glass and gasket off the door frame, *Figure 10*.
- Remove the old gasket from the door glass, *Figure 10*.

NOTE: If the old gasket was adhered to the door glass, it will require scraping off the old adhesive from the glass before installing the new door gasket.

DOOR GASKET INSTALLATION

- Apply a bead of a good quality water and temperature resistant silicone sealant, such as Dow Corning Silastic 732-RTV or equivalent (these are clear silicone sealants), around the entire area of the door glass gasket channel. This is the channel with the ribs that seal against the glass surface, *Figure 10*.
- Work the flange of the door glass into the gasket channel until glass flange is fully seated in the gasket channel, *Figure 11*.

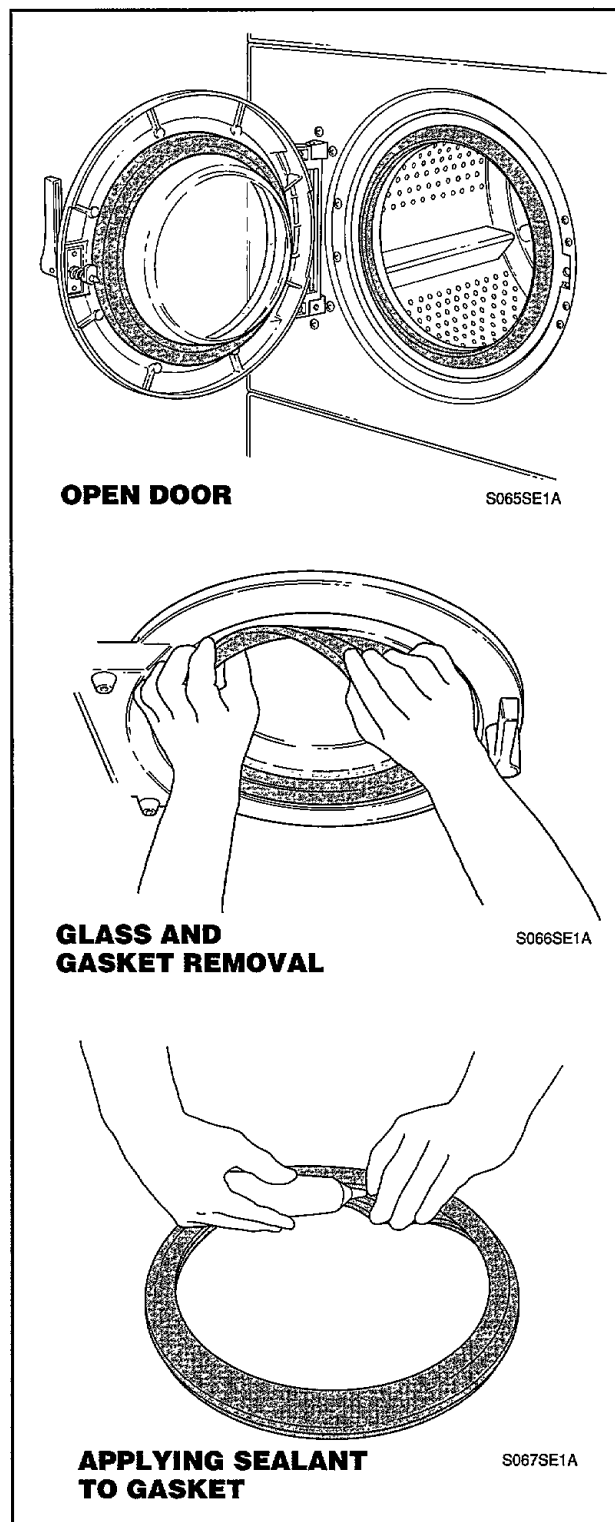

Figure 10

(continued)

▲ WARNING

To reduce the risk of electric shock, fire, explosion, serious injury or death:

- Disconnect electric power to the washer before servicing.
- Never start the washer with any guards/panels removed.
- Whenever ground wires are removed during servicing, these ground wires must be reconnected to ensure that the washer is properly grounded.

W003

DOOR GLASS AND GASKET INSTALLATION

- Locate the seam in the door gasket, this seam **MUST** be placed on the door at the 12 o'clock position.
- Starting at bottom of door, carefully tuck the new door gasket channel on the door frame, *Figure 11*.



**INSTALLING
GASKET ON GLASS**

S068SE1A

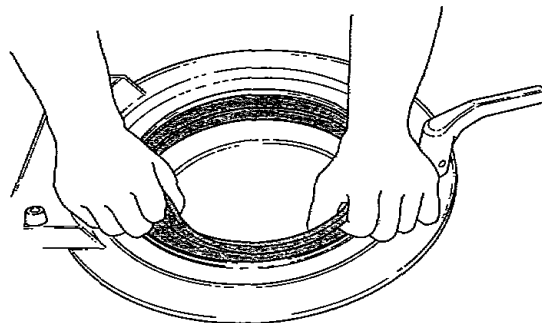

**INSTALLING DOOR
GLASS AND GASKET
ON DOOR FRAME**

S069SE1A

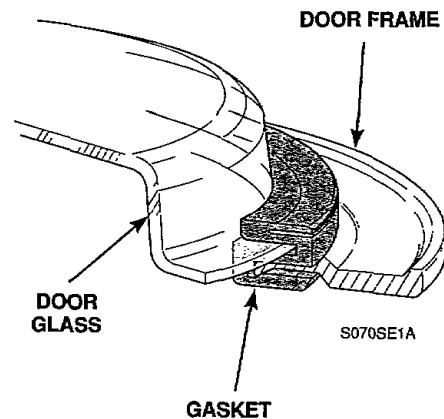

S070SE1A

Figure 11

▲ WARNING

To reduce the risk of electric shock, fire, explosion, serious injury or death:

- Disconnect electric power to the washer before servicing.
- Never start the washer with any guards/panels removed.
- Whenever ground wires are removed during servicing, these ground wires must be reconnected to ensure that the washer is properly grounded.

W003

8. CABINET TOP ASSEMBLY

- a. **METERED MODELS** — Unlock accumulator coin drop and pull out of washer as far as wires will permit, *Figure 4*.

NOTE: Lock is threaded and will require several counterclockwise turns to unlock.

NONMETERED MODELS — Remove the hex head screw and pull start switch out of washer as far as wires will permit, *Figure 4*.

- b. Disconnect the coin drop or start switch wire harness at the quick disconnect blocks.
- c. Remove the three screws holding control panel assembly to cabinet top, *Figure 4*.
- d. Tilt control panel assembly away from washer and disconnect wire harness at disconnect blocks, then remove control panel assembly.
- e. Open dispenser door, compress dispenser boot and push boot down through cabinet top, *Figure 12*.
- f. Remove two cabinet top hold-down screws, *Figure 13*.
- g. Tilt cabinet top back and hold in raised position with a small chain, *Figure 14*.
- h. Remove four screws and nuts holding cabinet top to hinges, *Figure 14*.

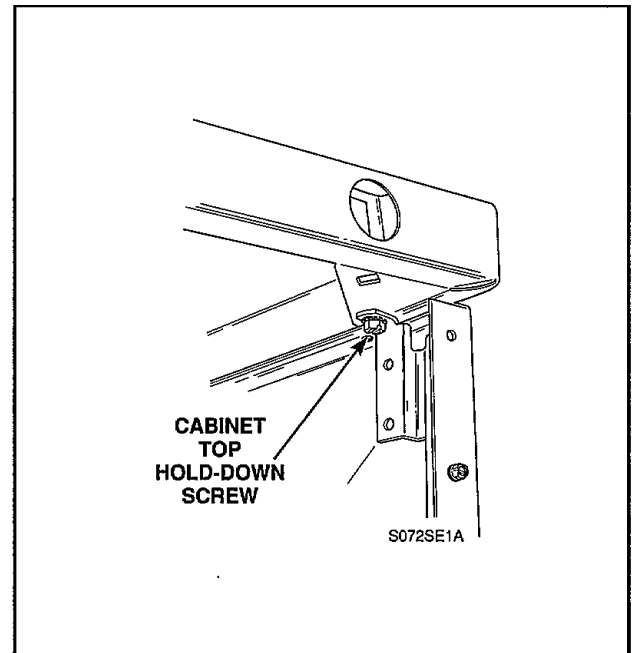

Figure 13

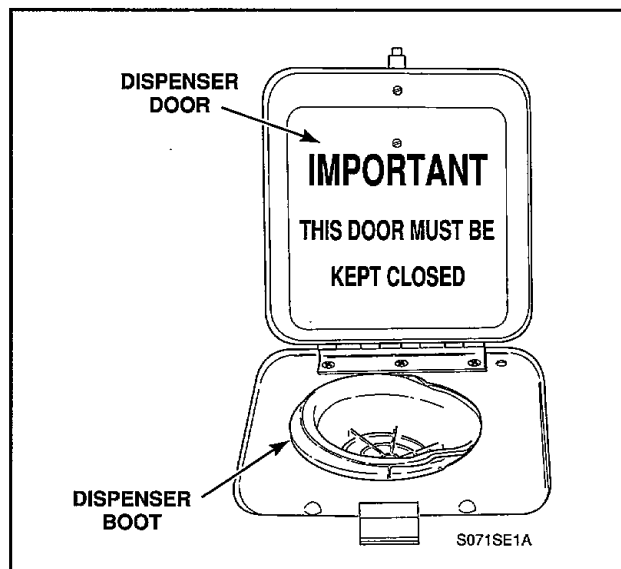

Figure 12

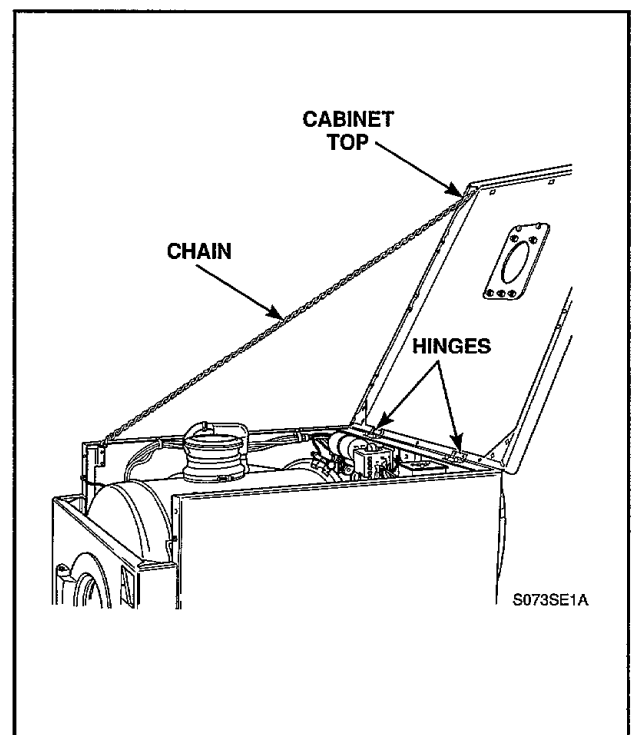

Figure 14

▲ WARNING

To reduce the risk of electric shock, fire, explosion, serious injury or death:

- Disconnect electric power to the washer before servicing.
- Never start the washer with any guards/panels removed.
- Whenever ground wires are removed during servicing, these ground wires must be reconnected to ensure that the washer is properly grounded.

W003

9. COIN VAULT — Metered Models

- Unlock coin drop.

NOTE: Lock is threaded and will require several counterclockwise turns to unlock.

- Pull coin drop out of control panel as far as wires will permit, then disconnect wire harness at disconnect blocks.
- Remove three screws holding control panel assembly to cabinet top, *Figure 4*.
- Tilt control panel assembly away from washer and disconnect wire harness at disconnect blocks and remove panel.
- Unlock and remove coin drawer, *Figure 15*.

NOTE: Coin drawer has threaded lock and will require several counterclockwise turns to unlock.

- Open dispenser door, compress dispenser boot and push boot down through cabinet top, *Figure 12*.
- Remove two cabinet top hold-down screws, *Figure 13*.
- Tilt cabinet top back and hold in raised position with small chain, *Figure 14*.
- Remove flathead screw and locknut holding coin vault to front panel, *Figure 16*.
- Remove two cap screws and lockwashers holding coin vault to right leg, *Figure 16*.

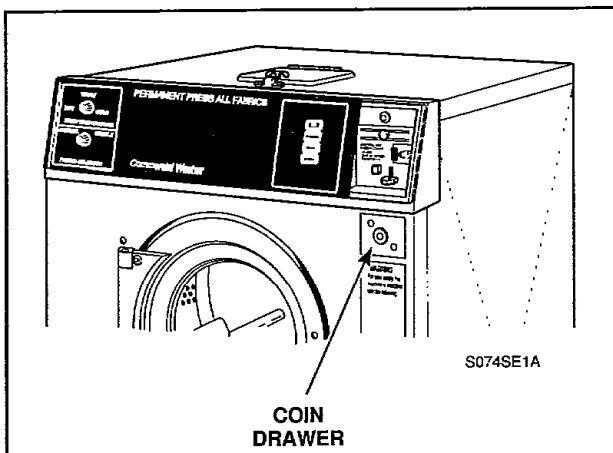

Figure 15

10. FRONT PANEL ASSEMBLY

- METERED MODELS** — Unlock accumulator coin drop and pull out of washer as far as wires will permit, *Figure 4*.

NOTE: Lock is threaded and will require several counterclockwise turns to unlock.

NONMETERED MODELS — Remove the hex head screw and pull start switch out of washer as far as wires will permit, *Figure 4*.

- Disconnect the coin drop or start switch wire harness at the quick disconnect blocks.
- Remove the three screws holding control panel assembly to cabinet top, *Figure 4*.
- Tilt control panel assembly away from washer and disconnect wire harness at disconnect blocks, then remove control panel assembly.
- Remove four screws holding lower front panel to washer base, *Figure 8*.
- Pull bottom of panel away from washer, lower panel, then remove panel from washer.

NOTE: PUMP MODELS — When lower front panel is reinstalled, end of overflow hose must protrude through hole in bottom of panel, *Figure 8*.

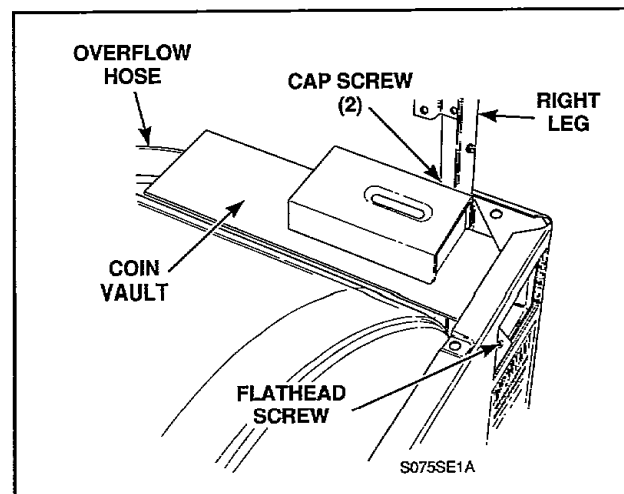

Figure 16

▲ WARNING

To reduce the risk of electric shock, fire, explosion, serious injury or death:

- Disconnect electric power to the washer before servicing.
- Never start the washer with any guards/panels removed.
- Whenever ground wires are removed during servicing, these ground wires must be reconnected to ensure that the washer is properly grounded.

W003

- g. Open dispenser door, compress dispenser boot and push boot down through cabinet top, *Figure 12*.
- h. **METERED MODELS** — Unlock and remove coin drawer, *Figure 15*.

NOTE: Coin drawer has threaded lock and will require several **counterclockwise** turns to unlock.

- i. Remove two cabinet top hold-down screws, *Figure 13*.
- j. Tilt cabinet top back and hold in raised position with a small chain, *Figure 14*.
- k. **METERED MODELS** — Remove flathead screw and locknut holding coin vault to front panel, *Figure 16*, then remove two cap screws and lockwashers holding coin vault to right leg, *Figure 16*.

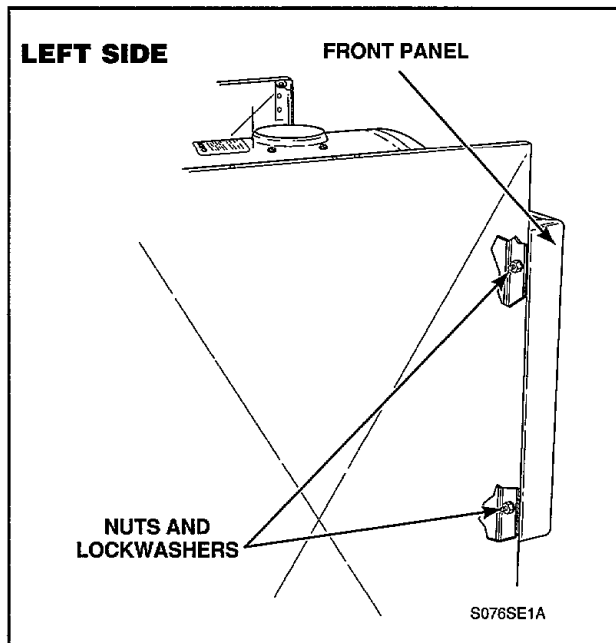

Figure 17

- l. Remove two nuts and lockwashers, *Figure 17*, holding front panel assembly to left leg (leave bolts in place).
- m. Remove nut and lockwashers (bottom), and cap screw (top), *Figure 18*, holding front panel assembly to right leg.

NOTE: PUMP MODELS — Overflow hose, *Figure 16*, may have to be pushed down to gain access to cap screw holding top of front panel assembly to right leg, *Figure 18*.

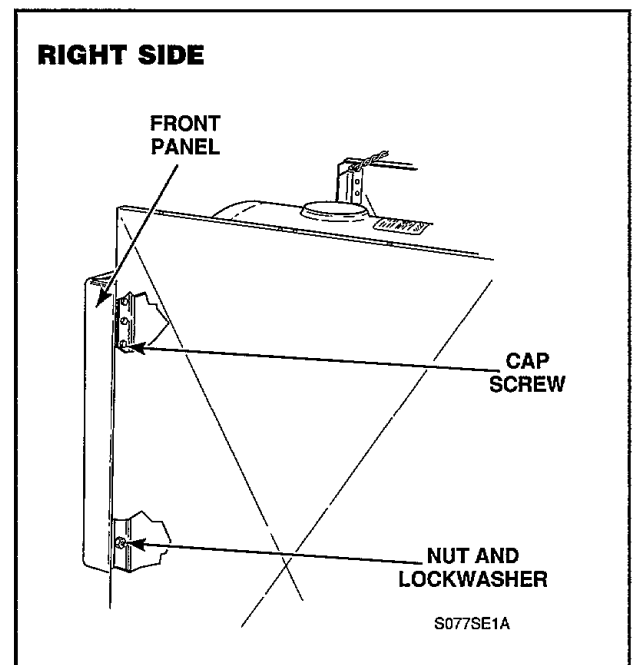

Figure 18

▲ WARNING

To reduce the risk of electric shock, fire, explosion, serious injury or death:

- **Disconnect electric power to the washer before servicing.**
- **Never start the washer with any guards/panels removed.**
- **Whenever ground wires are removed during servicing, these ground wires must be reconnected to ensure that the washer is properly grounded.**

W003

- n. Disconnect door lock wire harness at disconnect blocks.
- o. Disengage door seal from front panel flange, *Figure 19.*
- p. Carefully remove front panel assembly from washer.

IMPORTANT: When reinstalling front panel assembly, leave bolts loose until the door seal is properly positioned and the door opening is centered with the outer tub when loading door is in the closed position.

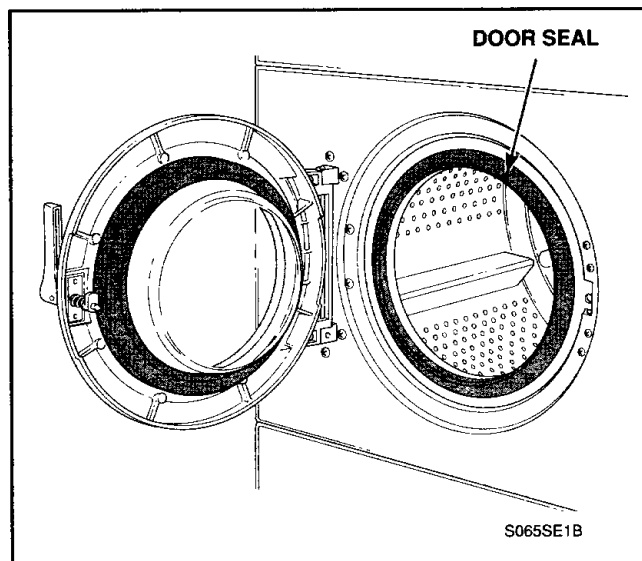

Figure 19

▲ WARNING

To reduce the risk of electric shock, fire, explosion, serious injury or death:

- **Disconnect electric power to the washer before servicing.**
- **Never start the washer with any guards/panels removed.**
- **Whenever ground wires are removed during servicing, these ground wires must be reconnected to ensure that the washer is properly grounded.**

W003

11. DOOR HINGE

- a. **METERED MODELS** — Unlock accumulator coin drop and pull out of washer as far as wires will permit, *Figure 4*.

NOTE: Lock is threaded and will require several counterclockwise turns to unlock.

NONMETERED MODELS — Remove the hex head screw and pull start switch out of washer as far as wires will permit, *Figure 4*.

- b. Disconnect the coin drop or start switch wire harness at the quick disconnect blocks.
- c. Remove the three screws holding control panel assembly to cabinet top, *Figure 4*.
- d. Tilt control panel assembly away from washer and disconnect wire harness at disconnect blocks, then remove control panel assembly.
- e. Remove four screws holding lower front panel to washer base, *Figure 8*.
- f. Pull bottom of panel away from washer, lower panel, then remove panel from washer.

NOTE: PUMP MODELS — When lower front panel is reinstalled, end of overflow hose must protrude through hole in bottom of panel, *Figure 8*.

- g. Open dispenser door, compress dispenser boot and push boot down through cabinet top, *Figure 12*.
- h. **METERED MODELS** — Unlock and remove coin drawer, *Figure 15*.

NOTE: Coin drawer has threaded lock and will require several counterclockwise turns to unlock.

- i. Remove two cabinet top hold-down screws, *Figure 13*.
- j. Tilt cabinet top back and hold in raised position with a small chain, *Figure 14*.
- k. **METERED MODELS** — Remove flathead screw and locknut holding coin vault to front panel, *Figure 16*, then remove two cap screws and lockwashers holding coin vault to right leg, *Figure 16*.
- l. Remove two nuts and lockwashers, *Figure 17*, holding front panel assembly to left leg (leave bolts in place).
- m. Remove nut and lockwasher (bottom), and cap screw (top) holding front panel assembly to right leg, *Figure 18*.

NOTE: PUMP MODELS - Overflow hose, *Figure 20*, may have to be pushed down to gain access to cap screw holding top of front panel assembly to right leg, *Figure 18*.

- n. Disconnect door lock wire harness at disconnect blocks.
- o. Disengage door seal from front panel flange, *Figure 19*.
- p. Carefully remove front panel assembly from washer.

IMPORTANT: When reinstalling front panel assembly, leave bolts loose until the door seal is properly positioned and the door opening is centered with the outer tub when loading door is in the closed position.

- q. Remove screws holding door hinge to front panel, *Figure 21*.

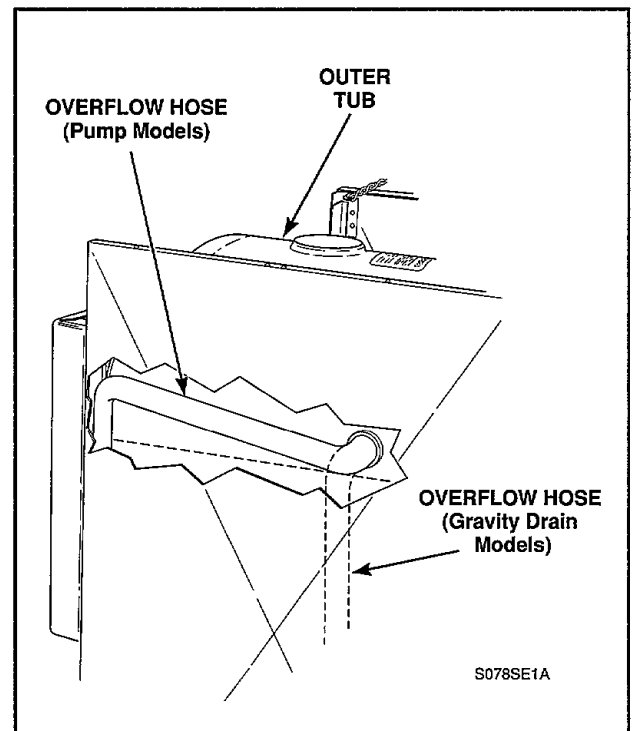

Figure 20

▲ WARNING

To reduce the risk of electric shock, fire, explosion, serious injury or death:

- Disconnect electric power to the washer before servicing.
- Never start the washer with any guards/panels removed.
- Whenever ground wires are removed during servicing, these ground wires must be reconnected to ensure that the washer is properly grounded.

W003

12. DOOR LOCK ASSEMBLY

- a. **METERED MODELS** — Unlock accumulator coin drop and pull out of washer as far as wires will permit, *Figure 4*.

NOTE: Lock is threaded and will require several counterclockwise turns to unlock.

NONMETERED MODELS — Remove the hex head screw and pull start switch out of washer as far as wires will permit, *Figure 4*.

- b. Disconnect the coin drop or start switch wire harness at the quick disconnect blocks.
c. Remove the three screws holding control panel assembly to cabinet top, *Figure 4*.
d. Tilt control panel assembly away from washer and disconnect wire harness at disconnect blocks, then remove control panel assembly.
e. Remove four screws holding lower front panel to washer base, *Figure 8*.
f. Pull bottom of panel away from washer, lower panel, then remove panel from washer.

NOTE: PUMP MODELS — When reinstalling lower front panel, end of overflow hose must protrude through hole in bottom of panel, *Figure 8*.

- g. Remove two wire harness clips from top flange of front panel, *Figure 21*.

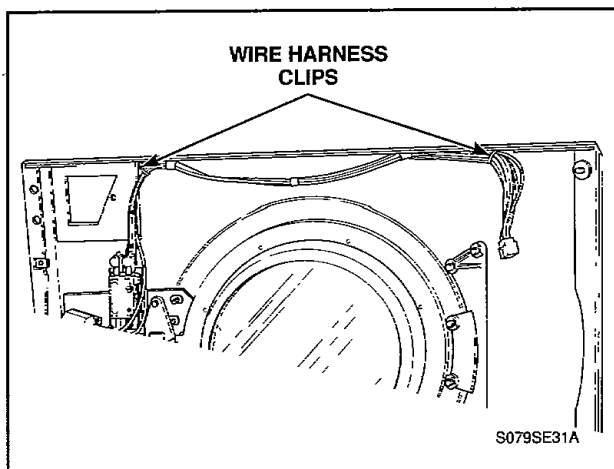

Figure 21

- h. While holding wire harness, open loading door and remove the four screws holding door lock assembly bracket to front panel, *Figure 22*.
i. Lower complete door lock assembly (by use of wire harness) and remove assembly through lower front panel opening, *Figure 22*.

NOTE: Refer to *Figure 23A* for assembly sequence.

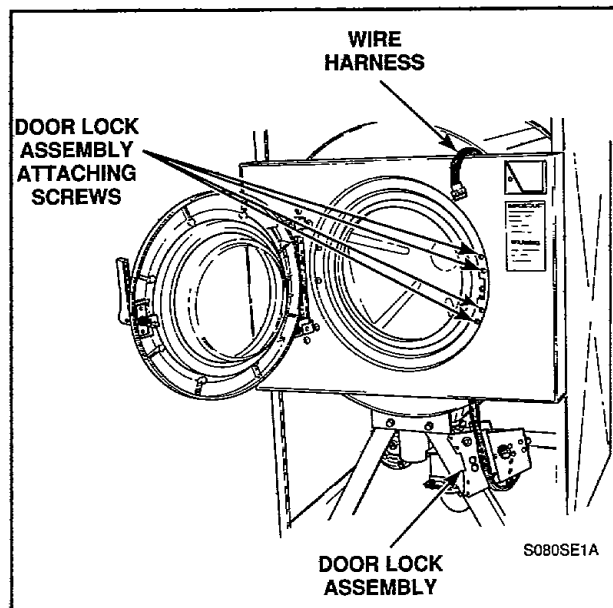

Figure 22

13. DOOR LOCK COMPONENTS

- a. **METERED MODELS** — Unlock accumulator coin drop and pull out of washer as far as wires will permit, *Figure 4*.

NOTE: Lock is threaded and will require several counterclockwise turns to unlock.

NONMETERED MODELS — Remove the hex head screw and pull start switch out of washer as far as wires will permit, *Figure 4*.

- b. Disconnect the coin drop or start switch wire harness at the quick disconnect blocks.
c. Remove the three screws holding control panel assembly to cabinet top, *Figure 4*.

▲ WARNING

To reduce the risk of electric shock, fire, explosion, serious injury or death:

- Disconnect electric power to the washer before servicing.
- Never start the washer with any guards/panels removed.
- Whenever ground wires are removed during servicing, these ground wires must be reconnected to ensure that the washer is properly grounded.

W003

- d. Tilt control panel assembly away from washer and disconnect wire harness at disconnect blocks, then remove control panel assembly.
- e. Remove four screws holding lower front panel to washer base, *Figure 8*.
- f. Pull bottom of panel away from washer, lower panel, then remove panel from washer.

NOTE: PUMP MODELS — When lower front panel is reinstalled, end of overflow hose must protrude through hole in bottom of panel, *Figure 8*.

- g. Remove two wire harness clips from top flange of front panel, *Figure 21*.
- h. While holding wire harness, open loading door and remove the four screws holding door lock assembly bracket to front panel, *Figure 22*.
- i. Lower complete door lock assembly (by use of wire harness) and remove assembly through lower front panel opening, *Figure 22*.

REMOVE DOOR LOCK SOLENOID

- a. Disconnect wires and unhook spring from solenoid.

NOTE: When connecting spring to solenoid, hook on spring must be facing down, *Figure 23*.

- b. Remove four screws holding solenoid to bracket, *Figure 23*.

REMOVE SWITCH — Door Lock or Door Safety

- a. Disconnect wires from switch.

NOTE: Refer to appropriate wiring diagram when rewiring switch.

- b. Remove two screws, nut and lockwasher holding switch to bracket, *Figure 23*.

IMPORTANT: When installing switch, insulation must be in place between switch and bracket. Adjust switch, paragraph 38.

REMOVE THERMOACTUATOR

- a. Disconnect wires from thermoactuator.

NOTE: Refer to appropriate wiring diagram when rewiring thermoactuator.

- b. Remove two screws holding the thermoactuator to bracket, *Figure 23*.

IMPORTANT: When installing thermoactuator, adjust per paragraph 38.

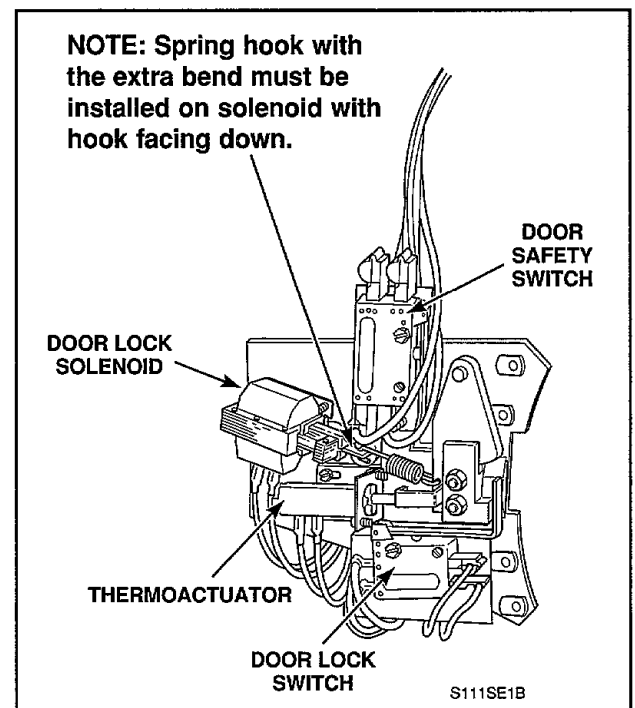

Figure 23

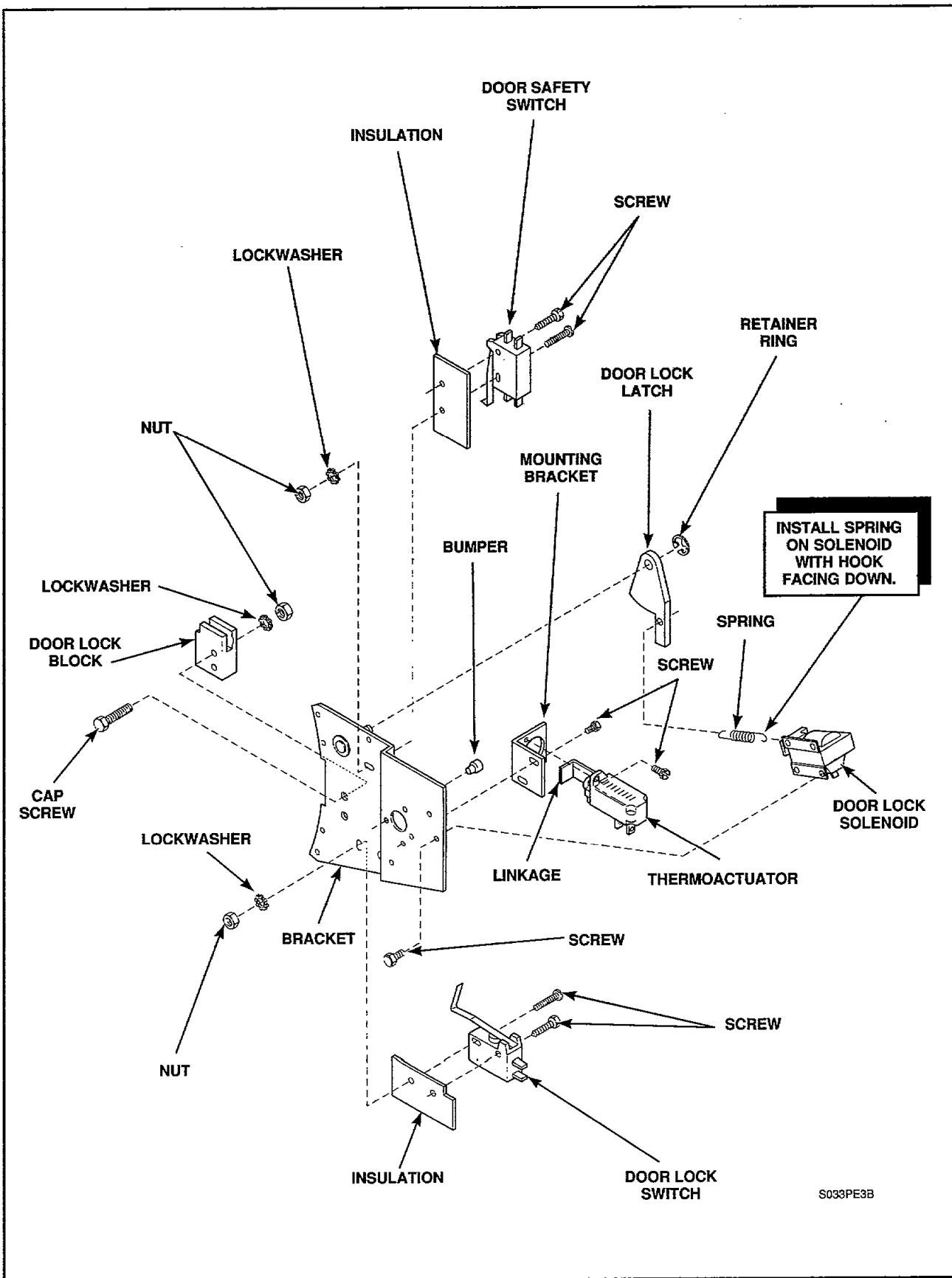

Figure 23A

▲ WARNING

To reduce the risk of electric shock, fire, explosion, serious injury or death:

- Disconnect electric power to the washer before servicing.
- Never start the washer with any guards/panels removed.
- Whenever ground wires are removed during servicing, these ground wires must be reconnected to ensure that the washer is properly grounded.

W003

14. DOOR SEAL

- a. **METERED MODELS** — Unlock accumulator coin drop and pull out of washer as far as wires will permit, *Figure 4*.

NOTE: Lock is threaded and will require several counterclockwise turns to unlock.

NONMETERED MODELS — Remove the hex head screw and pull start switch out of washer as far as wires will permit, *Figure 4*.

- b. Disconnect the coin drop or start switch wire harness at the quick disconnect blocks.
- c. Remove the three screws holding control panel assembly to the cabinet top, *Figure 4*.
- d. Tilt control panel assembly away from washer and disconnect wire harness at disconnect blocks, then remove control panel assembly.
- e. Remove four screws holding lower front panel to washer base, *Figure 8*.
- f. Pull bottom of panel away from washer, lower the panel, then remove from washer.

NOTE: PUMP MODELS — When reinstalling the lower front panel, end of overflow hose must protrude through hole in bottom of panel, *Figure 8*.

- g. **METERED MODELS** — Unlock and remove coin drawer, *Figure 15*.

NOTE: Coin drawer has threaded lock and will require several counterclockwise turns to unlock.

- h. Open dispenser door, compress dispenser boot and push boot down through cabinet top, *Figure 12*.
- i. Remove two cabinet top hold-down screws, *Figure 13*.
- j. Tilt cabinet top back and hold in raised position with a small chain, *Figure 14*.
- k. **METERED MODELS** — Remove flathead screw and locknut holding coin vault to front panel, *Figure 16*, then remove two cap screws and lockwashers holding coin vault to front panel, *Figure 16*.
- l. Remove two nuts and lockwashers, *Figure 17*, holding front panel assembly to left leg (leave bolts in place).

- m. Remove nut and lockwasher (bottom), and cap screw (top) holding front panel assembly to right leg, *Figure 18*.

NOTE: PUMP MODELS — Overflow hose, *Figure 16*, may have to be pushed down to gain access to cap screw holding top of front panel assembly to right leg, *Figure 18*.

- n. Disconnect door lock wire harness at disconnect blocks.
- o. Support front panel and disengage door seal from front panel flange, *Figure 19*.
- p. Carefully remove front panel assembly from washer.

IMPORTANT: When reinstalling front panel assembly, leave bolts loose until the door seal is properly positioned and the door opening is centered with the outer tub when loading door is in the closed position.

- q. Carefully unhook retainer strap spring from retainer strap, *Figure 24*.
- r. Pull door seal off flange of outer tub.

IMPORTANT: Reinstall door seal with seam at top, *Figure 24*.

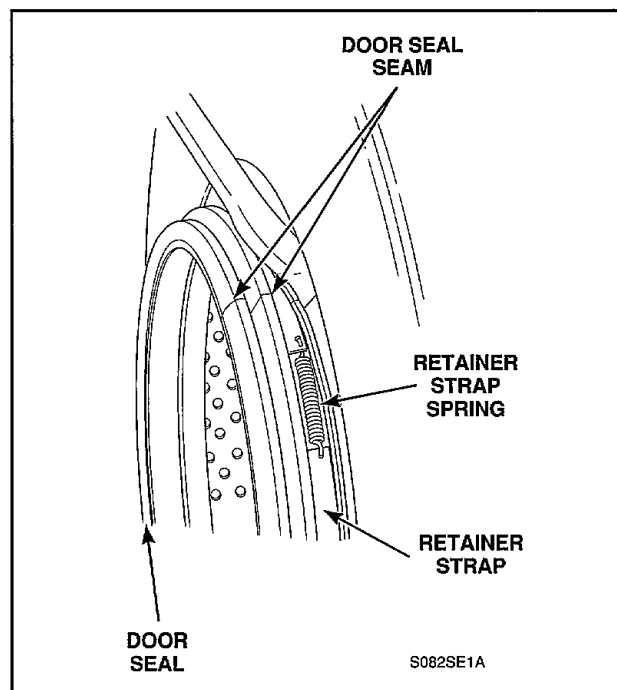

Figure 24

▲ WARNING

To reduce the risk of electric shock, fire, explosion, serious injury or death:

- Disconnect electric power to the washer before servicing.
- Never start the washer with any guards/panels removed.
- Whenever ground wires are removed during servicing, these ground wires must be reconnected to ensure that the washer is properly grounded.

W003

15. BUTTON TRAP

- Remove four screws holding lower front panel to washer base, *Figure 8*.
- Pull bottom of panel away from washer, lower panel, then remove panel from washer.

NOTE: PUMP MODELS — When installing lower front panel, insert end of overflow hose through hole in bottom of panel, *Figure 8*.

- Loosen clamp holding button trap to outer tub, *Figure 25*.

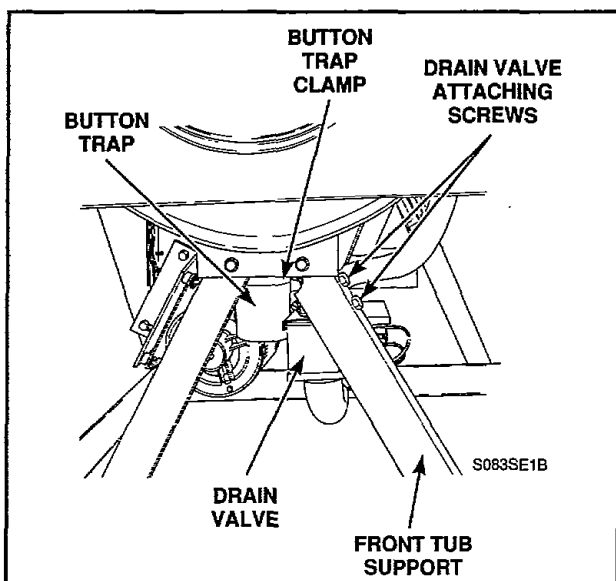

Figure 25

NOTE: PUMP MODELS (through Serial Number 9304013231) — When installing button trap, the divider in the outer tub outlet must fit into slot in the top of the filter assembly, (if present), *Figure 26*.

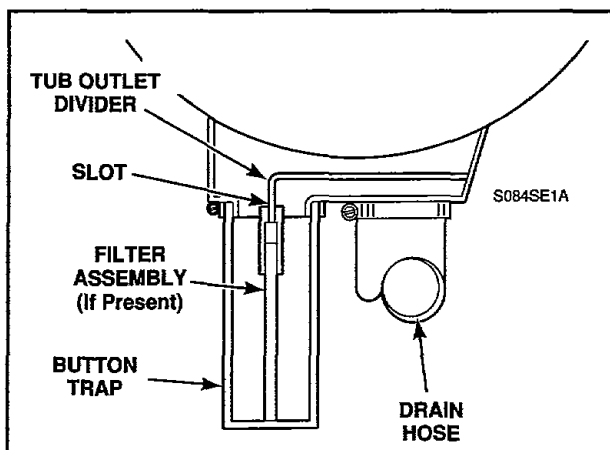

Figure 26

▲ WARNING

To reduce the risk of electric shock, fire, explosion, serious injury or death:

- Disconnect electric power to the washer before servicing.
- Never start the washer with any guards/panels removed.
- Whenever ground wires are removed during servicing, these ground wires must be reconnected to ensure that the washer is properly grounded.

W003

16. DRAIN VALVE AND BRACKET ASSEMBLY

- Remove four screws holding lower front panel to washer base, *Figure 8*.
- Pull bottom of panel away from washer, lower panel, then remove panel from washer.

NOTE: PUMP MODELS — When installing lower front panel, insert end of overflow hose through hole in bottom of panel, *Figure 8*.

- Disconnect wires from drain valve assembly.
- Loosen clamp holding button trap to outer tub, *Figure 25*.
- Loosen hose clamps and remove hoses from drain valve, *Figure 25*.
- Remove two screws, washers and nuts holding valve bracket to front tub support, *Figure 27*.
- Remove two screws, washers and nuts holding valve bracket to drain valve, *Figure 27*.

NOTE: Refer to *Figure 27* for drain valve assembly sequence.

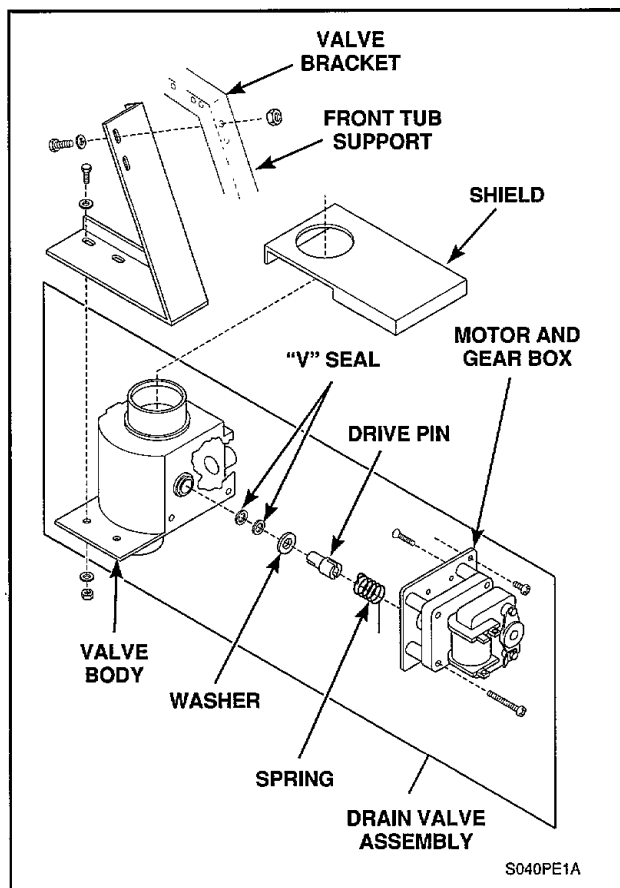

Figure 27

DISASSEMBLE DRAIN VALVE

- Remove two screws holding mounting plate to valve body, *Figure 27A*.
- While supporting drain valve assembly, remove one screw holding motor, gear box and mounting plate to valve body, *Figure 27A*.
- Allow motor to rotate approximately 180 degrees counterclockwise to release the spring tension, *Figure 27A*.
- Carefully remove the motor, gear box and mounting plate off valve body, *Figure 27A*.
- Remove spring from drive pin hole in mounting plate, *Figure 27A*.

NOTE: When reinstalling spring, position the spring arm between the two mounting plate posts as shown in *Figure 27A*.

- Remove three screws holding mounting plate to gear box.
- Remove drive pin from valve body, *Figure 27A*.

NOTE: When reinstalling drive pin, hold the ball steady inside the valve body with your finger, Align the bracket on the side of the valve ball with the center of the drive pin hole in the valve body. Insert the drive pin into the hole in the valve body making sure the bracket on the valve ball slides into the slot in the end of the drive pin, *Figure 27A*.

- Remove the stainless steel washer and the two "V" seals from the valve body.

NOTE: Install seals with lip toward inside of valve body. Apply No. 03637P Lubricant to inside diameter of seals before installing the drive pin.

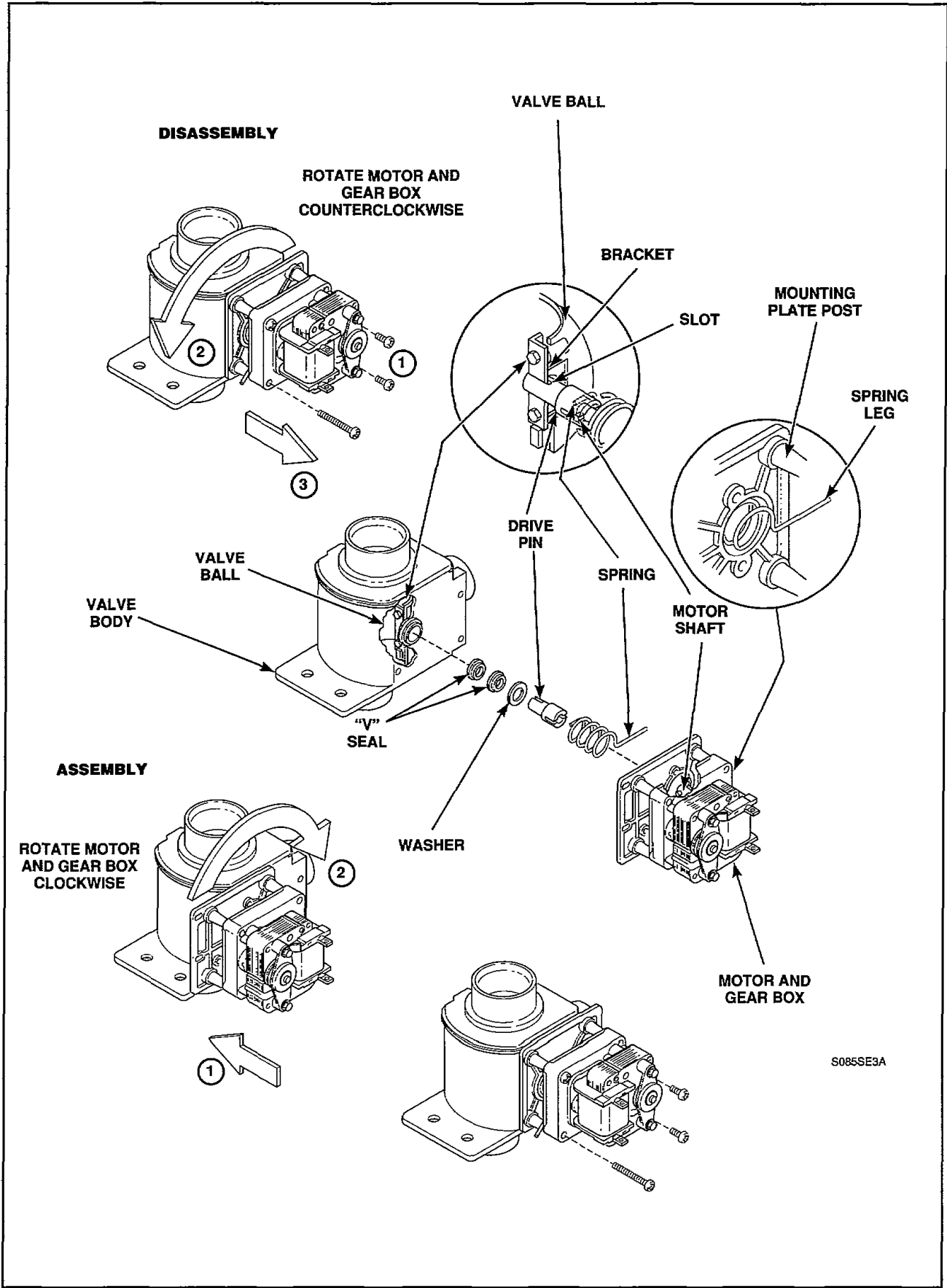

Figure 27A

▲ WARNING

To reduce the risk of electric shock, fire, explosion, serious injury or death:

- Disconnect electric power to the washer before servicing.
- Never start the washer with any guards/panels removed.
- Whenever ground wires are removed during servicing, these ground wires must be reconnected to ensure that the washer is properly grounded.

W003

17. TERMINAL BLOCK (Refer to *Figure 28*)

- Remove terminal block access plate from rear cross channel.
- Disconnect wires from terminal block.

IMPORTANT: Refer to wiring diagram when rewiring terminal block. Tighten nuts firmly.

- Remove two screws holding terminal block to bracket.

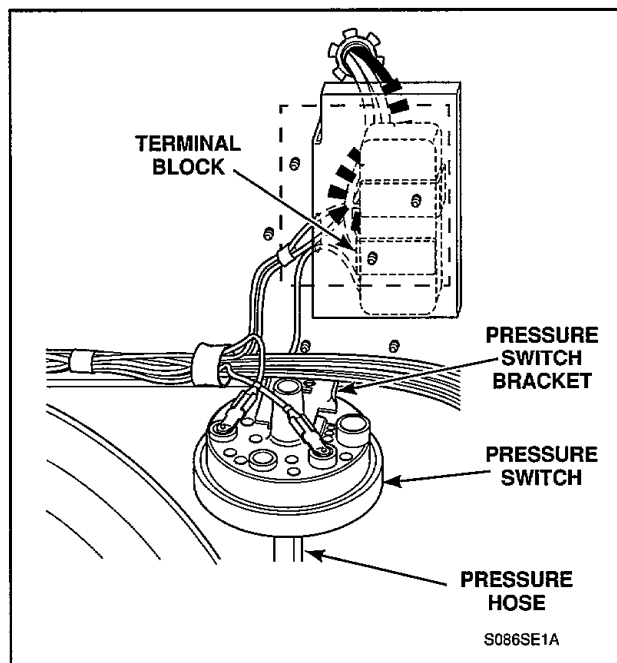

Figure 28

18. PRESSURE SWITCH

- METERED MODELS** — Unlock accumulator coin drop and pull out of washer as far as wires will permit, *Figure 4*.

NOTE: Lock is threaded and will require several **counterclockwise** turns to unlock.

NONMETERED MODELS — Remove the hex head screw and pull start switch out of washer as far as wires will permit, *Figure 4*.

- Disconnect the coin drop or start switch wire harness at the quick disconnect blocks.
- Remove the three screws holding control panel assembly to cabinet top, *Figure 4*.
- Tilt control panel assembly from washer and disconnect wire harness at disconnect blocks, then remove control panel assembly.
- Open dispenser door, compress dispenser boot and push boot down through cabinet top, *Figure 12*.
- Remove two cabinet top hold-down screws, *Figure 13*.
- Tilt cabinet top back and hold in raised position with a small chain, *Figure 14*.
- Disconnect pressure hose from pressure switch, *Figure 28*.

NOTE: Tape hose to right side panel to prevent hose from falling to base.

- Disconnect wires from pressure switch.

NOTE: Refer to wiring diagram when rewiring switch.

- Remove screw holding pressure switch and bracket to rear cross channel, *Figure 28*.

IMPORTANT: When installing pressure switch, blow air through pressure hose before connecting hose to switch to remove any condensation that may have accumulated in the hose.

▲ WARNING

To reduce the risk of electric shock, fire, explosion, serious injury or death:

- **Disconnect electric power to the washer before servicing.**
- **Never start the washer with any guards/panels removed.**
- **Whenever ground wires are removed during servicing, these ground wires must be reconnected to ensure that the washer is properly grounded.**

W003

19. MOTOR RELAY

- a. **METERED MODELS** — Unlock accumulator coin drop and pull out of washer as far as wires will permit, *Figure 4*.

- f. Remove two cabinet top hold-down screws, *Figure 13*.
- g. Tilt cabinet top back and hold in raised position with a small chain, *Figure 14*.
- h. Disconnect wires from relay.

NOTE: Lock is threaded and will require several counterclockwise turns to unlock.

NOTE: Refer to wiring diagram when rewiring relay.

NONMETERED MODELS — Remove the hex head screw and pull start switch out of washer as far as wires will permit, *Figure 4*.

- i. Remove nut holding motor relay to rear cross channel, *Figure 29*.

- b. Disconnect the coin drop or start switch wire harness at quick disconnect blocks.
- c. Remove the three screws holding control panel assembly to cabinet top, *Figure 4*.
- d. Tilt control panel assembly away from washer and disconnect wire harness at disconnect blocks, then remove control panel assembly.
- e. Open dispenser door, compress dispenser boot and push boot down through cabinet top, *Figure 12*.

▲ WARNING

To reduce the risk of electric shock, fire, explosion, serious injury or death:

- **Disconnect electric power to the washer before servicing.**
- **Never start the washer with any guards/panels removed.**
- **Whenever ground wires are removed during servicing, these ground wires must be reconnected to ensure that the washer is properly grounded.**

W003

20. TIMER ASSEMBLY — Cycle or Reversing

- a. **METERED MODELS** — Unlock accumulator coin drop and pull out of washer as far as wires will permit, *Figure 4*.

NOTE: Lock is threaded and will require several counterclockwise turns to unlock.

METERED MODELS — Remove the hex head screw and pull start switch out of washer as far as wires will permit, *Figure 4*.

- b. Disconnect the coin drop or start switch wire harness at the quick disconnect blocks.
- c. Remove the three screws holding control panel assembly to cabinet top, *Figure 4*.
- d. Tilt control panel assembly away from washer and disconnect wire harness at disconnect blocks, then remove control panel assembly.
- e. Open dispenser door, compress dispenser boot and push boot down through cabinet top, *Figure 12*.
- f. Remove two cabinet top hold-down screws, *Figure 13*.

- g. Tilt cabinet top back and hold in raised position with a small chain, *Figure 14*.
- h. **CYCLE TIMER:** Loosen setscrew holding knob to timer shaft, *Figure 29*, and remove knob.
- i. Remove three screws holding timer to mounting bracket, *Figure 29*.
- j. Disconnect wires from timer.

NOTE: Refer to wiring diagram when rewiring timer.

TO REMOVE TIMER MOTOR (Cycle Timer)

- a. Remove timer assembly.
- b. Remove two nuts holding timer motor to timer assembly.
- c. Disconnect timer motor lead wires from timer.

NOTE: Refer to wiring diagram when rewiring timer motor lead wires.

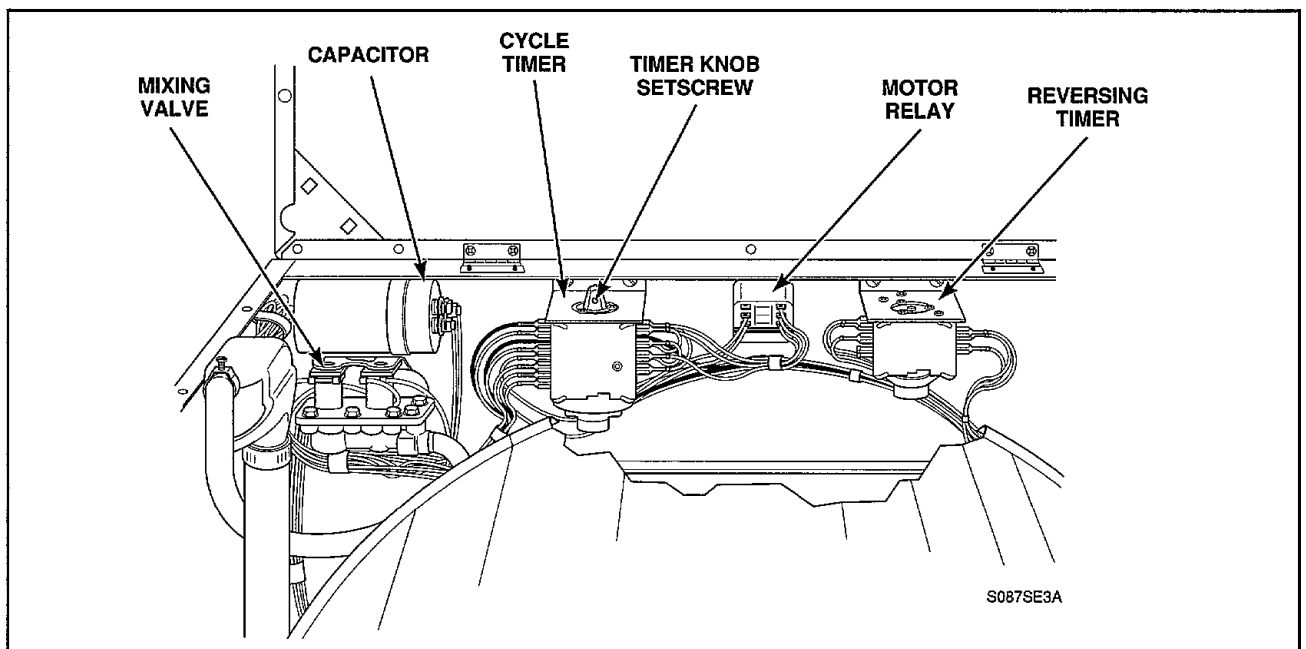

S087SE3A

Figure 29

▲ WARNING

To reduce the risk of electric shock, fire, explosion, serious injury or death:

- **Disconnect electric power to the washer before servicing.**
- **Never start the washer with any guards/panels removed.**
- **Whenever ground wires are removed during servicing, these ground wires must be reconnected to ensure that the washer is properly grounded.**

W003

21. CAPACITOR

▲ WARNING

To reduce the risk of an electric shock, before handling capacitor, touch capacitor terminals with ends of insulated wires to discharge capacitor.

- a. **METERED MODELS** — Unlock accumulator coin drop and pull out of washer as far as wires will permit, *Figure 4*.

NOTE: Lock is threaded and will require several counterclockwise turns to unlock.

NONMETERED MODELS — Remove the hex head screw and pull start switch out of washer as far as wires will permit, *Figure 4*.

- b. Disconnect the coin drop or start switch wire harness at the quick disconnect blocks.
- c. Remove the three screws holding control panel assembly to cabinet top, *Figure 4*.
- d. Tilt control panel assembly away from washer and disconnect wire harness at disconnect blocks, then remove control panel assembly.
- e. Open dispenser door, compress dispenser boot and push boot down through cabinet top, *Figure 12*.
- f. Remove two cabinet top hold-down screws, *Figure 13*.
- g. Tilt cabinet top back and hold in raised position with a small chain, *Figure 14*.
- h. Disconnect wires from capacitor.
- i. Remove capacitor clamp screw holding capacitor to cross channel, *Figure 29*.

22. MIXING VALVE

- a. **METERED MODELS** — Unlock accumulator coin drop and pull out of washer as far as wires will permit, *Figure 4*.

NOTE: Lock is threaded and will require several counterclockwise turns to unlock.

NONMETERED MODELS — Remove the hex head screw and pull start switch out of washer as far as wires will permit, *Figure 4*.

- b. Disconnect the coin drop or start switch wire harness at the quick disconnect blocks.
- c. Remove the three screws holding control panel assembly to cabinet top, *Figure 4*.
- d. Tilt control panel assembly away from washer and disconnect wire harness at disconnect blocks, then remove control panel assembly.
- e. Open dispenser door, compress dispenser boot and push boot down through cabinet top, *Figure 12*.
- f. Remove two cabinet top hold-down screws, *Figure 13*.
- g. Tilt cabinet top back and hold in raised position with a small chain, *Figure 14*.

▲ WARNING

To reduce the risk of an electric shock, before handling capacitor, touch capacitor terminals with ends of insulated wires to discharge capacitor.

- h. Disconnect wires from capacitor.
- i. Remove screw holding mixing valve to rear cross channel, *Figure 29*.

NOTE: Refer to *Figure 30* for assembly sequence of mixing valve.

- j. Disconnect hoses and wires from mixing valve.

NOTE: Refer to wiring diagram when rewiring mixing valve solenoids.

MIXING VALVE ASSEMBLY

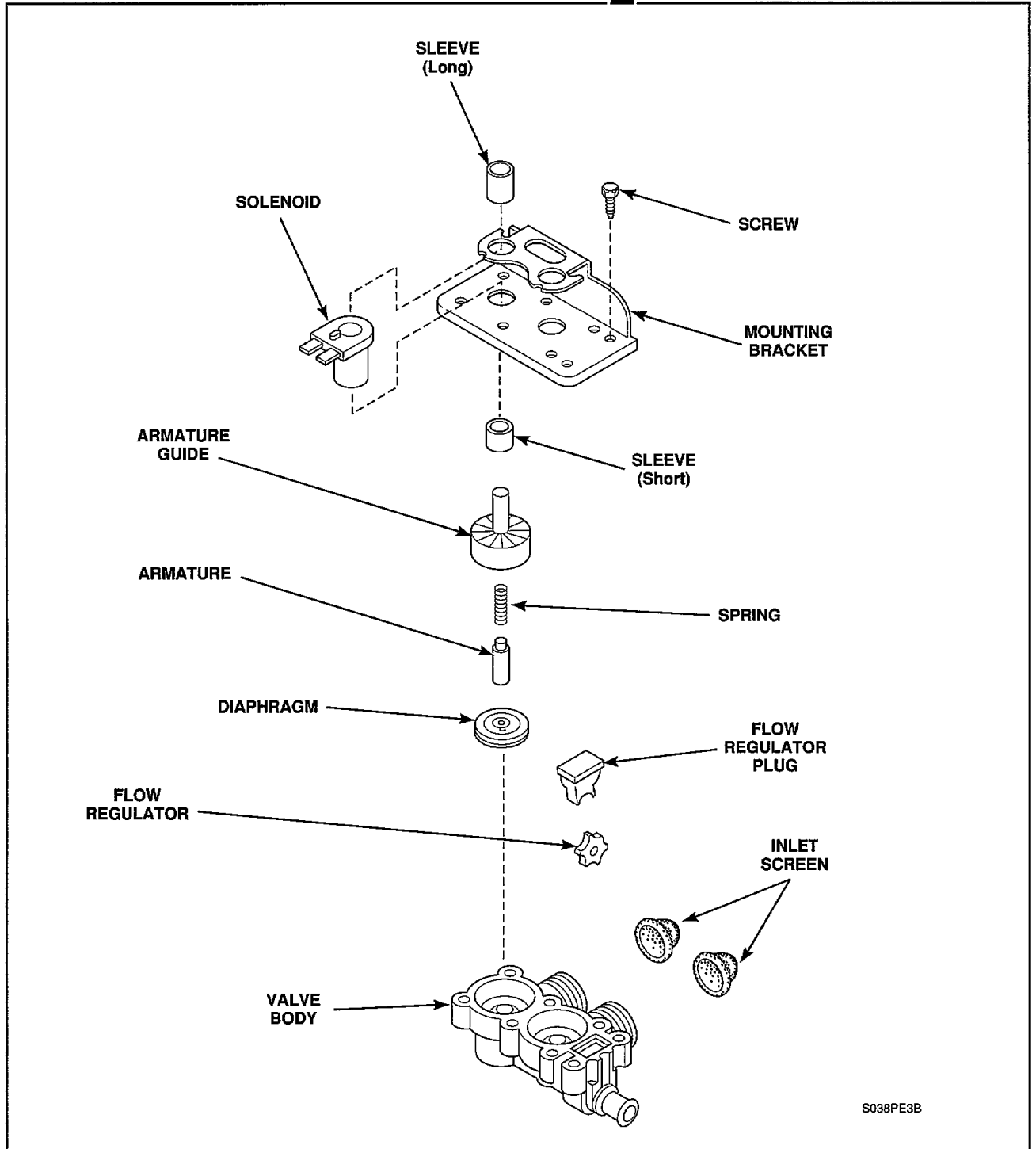
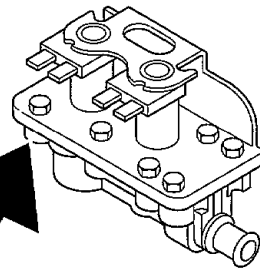

S038PE3B

Figure 30

▲ WARNING

To reduce the risk of electric shock, fire, explosion, serious injury or death:

- Disconnect electric power to the washer before servicing.
- Never start the washer with any guards/panels removed.
- Whenever ground wires are removed during servicing, these ground wires must be reconnected to ensure that the washer is properly grounded.

W003

23. WATER INLET

- a. **METERED MODELS** — Unlock accumulator coin drop and pull out of washer as far as wires will permit, *Figure 4*.

NOTE: Lock is threaded and will require several counterclockwise turns to unlock.

NONMETERED MODELS — Remove the hex head screw and pull start switch out of washer as far as wires will permit, *Figure 4*.

- b. Disconnect the coin drop or start switch wire harness at the quick disconnect blocks.
- c. Remove the three screws holding control panel assembly to cabinet top, *Figure 4*.
- d. Tilt control panel assembly away from washer and disconnect wire harness at disconnect blocks, then remove control panel assembly.
- e. Open dispenser door, compress dispenser boot and push boot down through cabinet top, *Figure 12*.
- f. Remove two cabinet top hold-down screws, *Figure 13*.
- g. Tilt cabinet top back and hold in raised position with a small chain, *Figure 14*.
- h. Loosen hose clamps and remove hoses from water inlet, *Figure 31*.

IMPORTANT: Install the water inlet-to-tub hose in front of mixing valve water inlet hose, *Figure 31*.

- i. Remove two screws and fiber washer holding water inlet to left side panel flange.

NOTE: When installing water inlet, be sure fiber washer is repositioned on rear screw between the inlet and flange of left side panel. DO NOT overtighten screws.

24. WATER INLET-TO-TUB HOSE

- a. **METERED MODELS** — Unlock accumulator coin drop and pull out of washer as far as wires will permit, *Figure 4*.

NOTE: Lock is threaded and will require several counterclockwise turns to unlock.

NONMETERED MODELS — Remove the hex head screw and pull start switch out of washer as far as wires will permit, *Figure 4*.

- b. Disconnect the coin drop or start switch wire harness at the quick disconnect blocks.
- c. Remove the three screws holding control panel assembly to cabinet top, *Figure 4*.
- d. Tilt control panel assembly away from washer and disconnect wire harness at disconnect blocks, then remove control panel assembly.
- e. Remove four screws holding lower front panel to washer base, *Figure 8*.
- f. Pull bottom of panel away from washer, lower panel, then remove panel from washer.

NOTE: PUMP MODELS — When lower front panel is reinstalled, end of overflow hose must protrude through hole in bottom of panel, *Figure 8*.

- g. Disconnect door lock wire harness at disconnect blocks.
- h. Support front panel and disengage door seal from front panel, *Figure 19*.
- i. Carefully remove front panel assembly from washer.

IMPORTANT: When reinstalling front panel assembly, leave bolts loose until the door seal is properly positioned and the door opening is centered with the outer tub when loading door is in the closed position.

- j. Disconnect water inlet-to-tub hose from water inlet and from outer tub, *Figure 31*.

IMPORTANT: Install the water inlet-to-tub hose in front of mixing valve-to-water inlet hose, *Figure 31*.

NOTE: Before installing hose in outer tub, apply a small amount of No. 27615P Sealant to hose flange to assure a water tight seal.

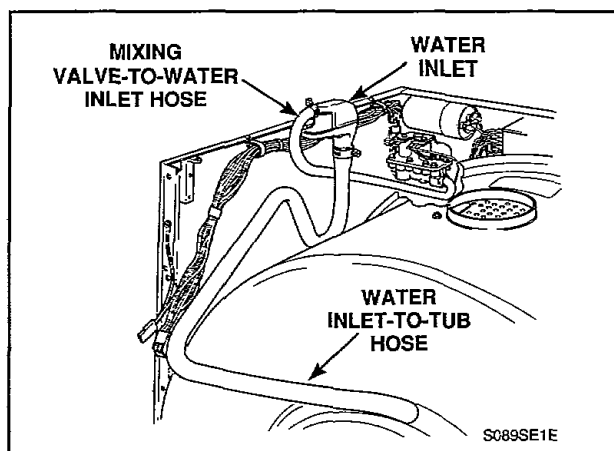

Figure 31

▲ WARNING

To reduce the risk of electric shock, fire, explosion, serious injury or death:

- Disconnect electric power to the washer before servicing.
- Never start the washer with any guards/panels removed.
- Whenever ground wires are removed during servicing, these ground wires must be reconnected to ensure that the washer is properly grounded.

W003

25. OVERFLOW HOSE

- a. **METERED MODELS** — Unlock accumulator coin drop and pull out of washer as far as wires will permit, *Figure 4*.

NOTE: Lock is threaded and will require several counterclockwise turns to unlock.

NONMETERED MODELS — Remove the hex head screw and pull start switch out of washer as far as wires will permit, *Figure 4*.

- b. Disconnect the coin drop or start switch wire harness at the quick disconnect blocks.
- c. Remove the three screws holding control panel assembly to cabinet top, *Figure 4*.
- d. Tilt control panel assembly away from washer and disconnect wire harness at disconnect blocks, then remove control panel assembly.
- e. Remove four screws holding lower front panel to washer base, *Figure 8*.
- f. Pull bottom of panel away from washer, lower panel, then remove panel from washer.

NOTE: PUMP MODELS — When lower front panel is reinstalled, end of overflow hose must protrude through hole in bottom of panel, *Figure 8*.

- g. Open dispenser door, compress dispenser boot and push boot down through cabinet top, *Figure 12*.
- h. Remove two cabinet top hold-down screws, *Figure 13*.
- i. Tilt cabinet top back and hold in raised position with a small chain, *Figure 14*.
- j. **GRAVITY DRAIN MODELS** — Loosen hose clamp and remove overflow hose from back side of drain valve.
- k. Disconnect overflow hose from outer tub, *Figure 32*. DO NOT chip porcelain tub.

NOTE: Before installing hose in outer tub, apply a small amount of No. 27615P Sealant to hose flange to assure a water tight seal.

IMPORTANT: When installing overflow hose (pump models), run hose on incline toward front of washer, *Figure 32*.

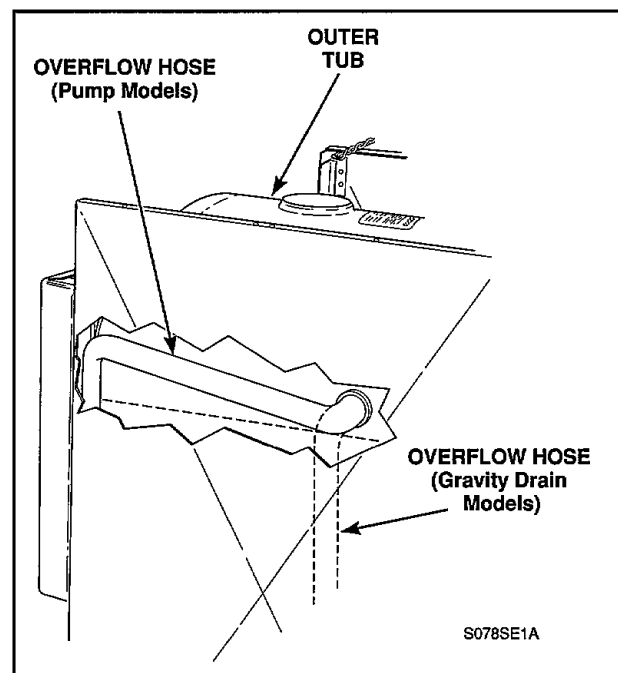

Figure 32

▲ WARNING

To reduce the risk of electric shock, fire, explosion, serious injury or death:

- Disconnect electric power to the washer before servicing.
- Never start the washer with any guards/panels removed.
- Whenever ground wires are removed during servicing, these ground wires must be reconnected to ensure that the washer is properly grounded.

W003

26. CROSS CHANNEL ASSEMBLY

- a. **METERED MODELS** — Unlock accumulator coin drop and pull out of washer as far as wires will permit, *Figure 4*.

NOTE: Lock is threaded and will require several **counterclockwise** turns to unlock.

NONMETERED MODELS — Remove the hex head screw and pull start switch out of washer as far as wires will permit, *Figure 4*.

- b. Disconnect the coin drop or start switch wire harness at the quick disconnect blocks.
- c. Remove the three screws holding control panel assembly to cabinet top, *Figure 4*.
- d. Tilt control panel assembly away from washer and disconnect wire harness at disconnect blocks, then remove control panel assembly.
- e. Open dispenser door, compress dispenser boot and push boot down through cabinet top, *Figure 12*.
- f. Remove two cabinet top hold-down screws, *Figure 13*.
- g. Tilt cabinet top back and hold in raised position with a small chain, *Figure 14*.
- h. Remove four screws and nuts holding cabinet top to hinges, *Figure 14*, and carefully remove cabinet top from washer.

- i. Disconnect hoses and wires from mixing valve, solenoids and from pressure switch.

NOTE: Refer to wiring diagram when rewiring mixing valve solenoids and pressure switch.

- j. Disconnect main wire harness at connectors, external ground wire from rear cross channel and main wires from terminal block.

IMPORTANT: Refer to wiring diagram when rewiring terminal block. Make sure nuts are tightened firmly.

- k. Remove cable clips from left side panel.
- l. Disconnect motor wire harness at disconnect block.
- m. **PUMP MODELS** — Disconnect pump motor wires at connectors.
- n. Carefully remove screws and lockwashers holding cross channel to each side panel, *Figure 33*.
- o. Support cross channel and remove four screws holding top edge of rear panel to cross channel, *Figure 33*.

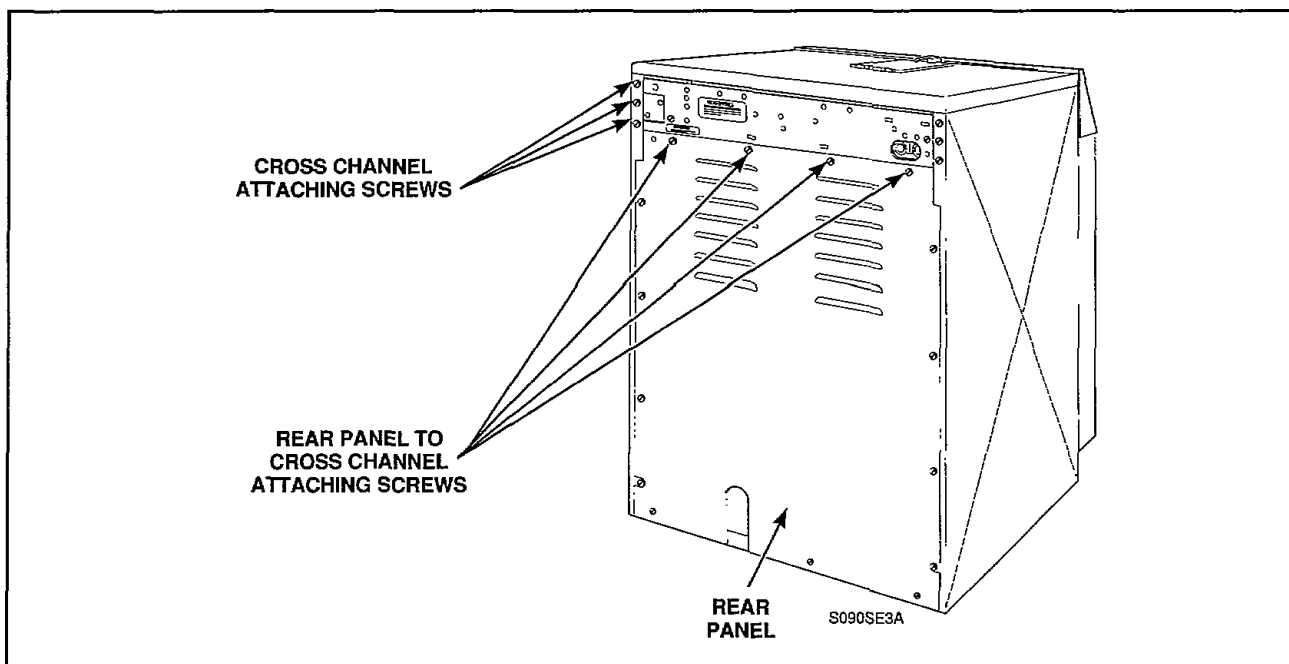

Figure 33

▲ WARNING

To reduce the risk of electric shock, fire, explosion, serious injury or death:

- Disconnect electric power to the washer before servicing.
- Never start the washer with any guards/panels removed.
- Whenever ground wires are removed during servicing, these ground wires must be reconnected to ensure that the washer is properly grounded.

W003

27. DRIVE MOTOR AND MOUNTING BRACKET

NOTE: if clutch shoes sound noisy, refer to paragraph 29.

- Remove screws holding rear panel to washer, *Figure 33*.
- Run belt off cylinder pulley, *Figure 34*.
- Disconnect motor wire harness at disconnect blocks.
- Remove two mounting bracket pivot bolts and lockwashers, *Figure 34*, and allow assembly to pivot down and rest on washer base. Belt adjusting bolts may have to be loosened slightly.
- Remove two belt adjusting bolts, washers and lockwashers, *Figure 34*, and lift assembly out of washer.

NOTE: When reinstalling assembly, adjust belt, paragraph 36.

ATTENTION

Superload washers installed with an inadequate service area behind the washer, follow these steps for removing drive motor and mounting bracket assembly.

- Remove four screws holding lower front panel to washer base, *Figure 8*.
- Pull bottom of panel away from washer, lower panel, then remove panel from washer.

NOTE: PUMP MODELS — When lower front panel is reinstalled, end of overflow hose must protrude through hole in bottom of panel, *Figure 8*.

- GRAVITY DRAIN MODELS —** Disconnect wires from drain valve.
- Disconnect motor wire harness at disconnect blocks.
- Remove two mounting bracket pivot bolts and lockwashers, *Figure 35*, and allow assembly to pivot down and rest on washer base. Belt adjusting bolts may have to be loosened slightly.
- Remove two belt adjusting bolts, washers and lockwashers, *Figure 35*, and carefully lift assembly out through front of washer.

IMPORTANT: When reinstalling motor and bracket assembly, tighten pivot and adjusting bolts up snug. Tap bottom of mounting bracket with hammer to tighten belt. Tighten adjusting bolts securely, then tighten pivot bolts. Proper belt tension is obtained when belt can be deflected approximately 1/2 inch (12.7 mm) from normal position when moderate pressure (5 pounds - 2.25 kg) is applied to a point midway between pulleys.

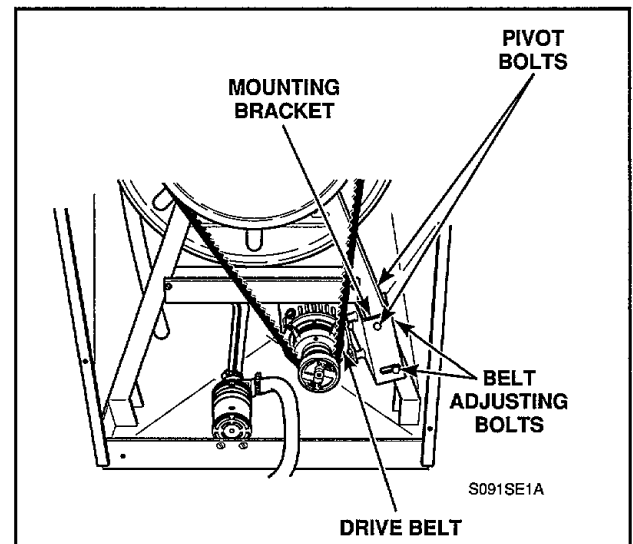

Figure 34

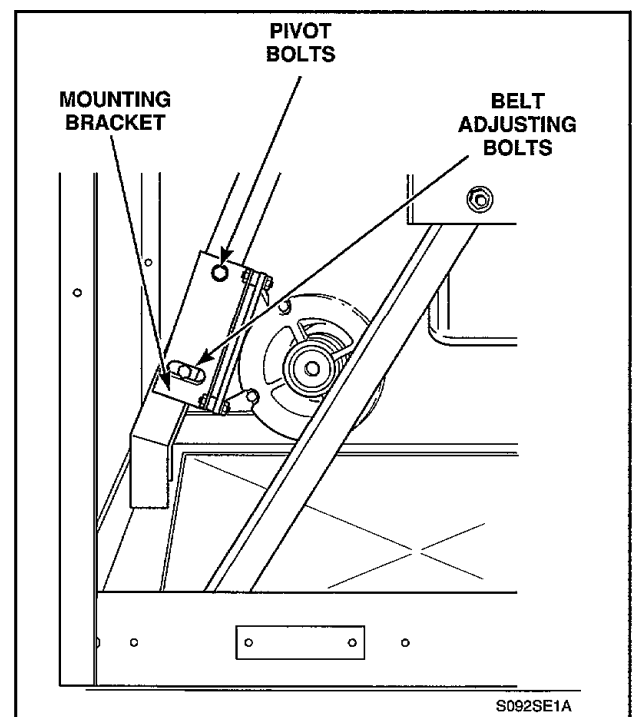

Figure 35

▲ WARNING

To reduce the risk of electric shock, fire, explosion, serious injury or death:

- Disconnect electric power to the washer before servicing.
- Never start the washer with any guards/panels removed.
- Whenever ground wires are removed during servicing, these ground wires must be reconnected to ensure that the washer is properly grounded.

W003

28. DRIVE MOTOR

NOTE: If clutch shoes sound noisy, refer to paragraph 29.

- Remove drive motor and mounting bracket, paragraph 27.
- Remove four nuts, washers and lockwashers holding drive motor to rubber motor mounts, *Figure 36*.

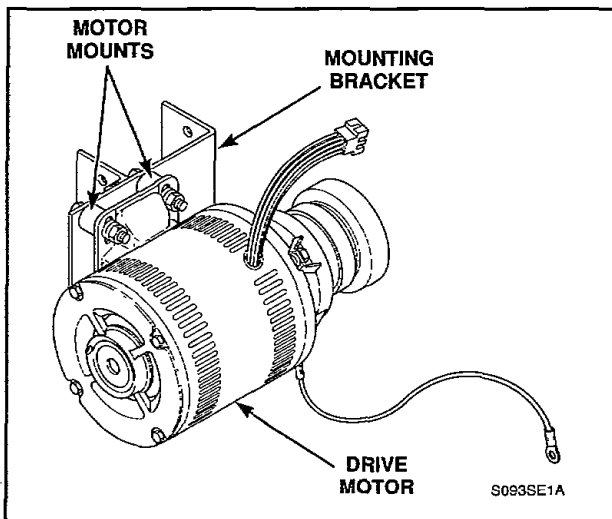

Figure 36

29. NO. 355P3 CLUTCH REPAIR KIT (Refer to *Figure 37*)

IMPORTANT: When checking clutch operation, a momentary slipping noise may be heard when the motor drive goes into the spin mode. This is normal operation caused by the drive clutch pads engaging against the clutch drum.

TO DISASSEMBLE CLUTCH ASSEMBLY

- Remove rear panel from washer, *Figure 33*.
- Block the clutch assembly using a screwdriver between the clutch driver and the back of the clutch drum.

IMPORTANT: Do not use the screwdriver in the area of the drum facing.

- Carefully unhook springs from clutch shoes using a needle nose pliers, or screwdriver.
- Pry push nuts off clutch driver studs using a screwdriver or by splitting push nuts with a side cutting pliers, then remove the spring washers, clutch shoes and bushings.

TO ASSEMBLE CLUTCH REPAIR KIT

IMPORTANT: All the parts included in the repair kit **MUST** be installed, **DO NOT** replace only the worn parts.

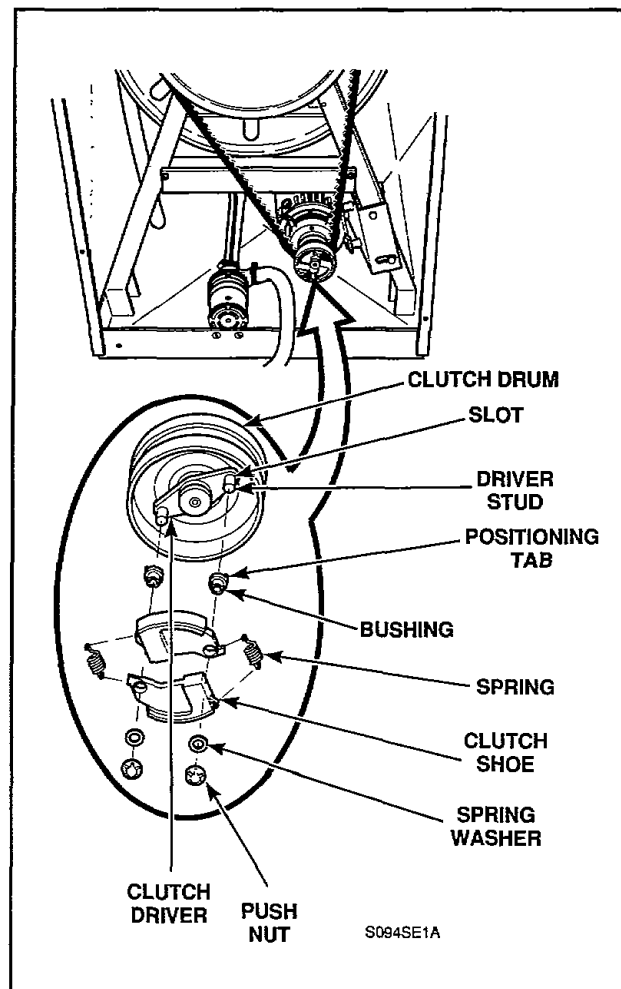

Figure 37

▲ WARNING

To reduce the risk of electric shock, fire, explosion, serious injury or death:

- Disconnect electric power to the washer before servicing.
- Never start the washer with any guards/panels removed.
- Whenever ground wires are removed during servicing, these ground wires must be reconnected to ensure that the washer is properly grounded.

W003

- Place new bushings on clutch driver studs with positioning tabs fitting into slots in driver.
- Place new clutch shoes over bushings on driver studs.

NOTE: See *Figure 37* for clutch shoe assembly sequence. Arrows must be facing out on shoes, and pointing in direction of spin.

- Place new spring washers on driver studs.
- Press new push nuts on driver studs.

IMPORTANT: When installing push nuts, do not press nuts on studs to the point of binding the clutch shoes. Correct force is 56 to 67 pounds (25.40 to 30.39 kg).

- Carefully hook new springs on clutch shoes.

IMPORTANT: Do not overstretch springs as it will affect the washer operation.

30. PUMP ASSEMBLY

- Remove screws holding rear panel to washer, *Figure 33*.
- Disconnect pump wires at connectors.
- Remove nut holding ground wire to rear support.
- Loosen hose clamps and remove hoses from pump, *Figure 34*.
- Remove two screws, nuts and lockwashers holding pump mounting bracket to washer base, *Figure 34*.
- Remove four screws holding pump body to mounting bracket, *Figure 38*.

NOTE: See *Figure 38* for pump assembly sequence.

IMPORTANT: Mark pump body before disassembling so body can be reinstalled in same position.

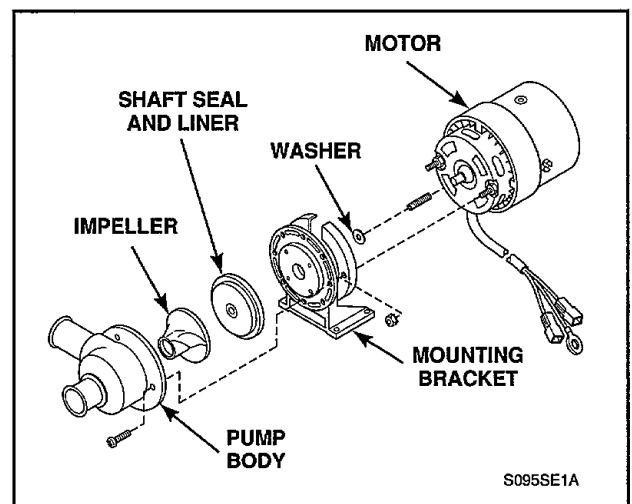

Figure 38

▲ WARNING

To reduce the risk of electric shock, fire, explosion, serious injury or death:

- **Disconnect electric power to the washer before servicing.**
- **Never start the washer with any guards/panels removed.**
- **Whenever ground wires are removed during servicing, these ground wires must be reconnected to ensure that the washer is properly grounded.**

W003

31. PULLEY AND HUB ASSEMBLY

- Remove screws holding rear panel to washer, *Figure 33*.
- Run belt off pulley, *Figure 34*.
- Remove cap screw, lockwasher and flat washer from end of cylinder shaft, *Figure 39*.
- Loosen two setscrews, *Figure 39*, holding pulley and hub assembly to cylinder shaft and pull pulley off shaft.

NOTE: When reinstalling pulley, cap screw should be tightened before tightening the setscrews. Torque the cap screw between 12 to 15 foot pounds and the two setscrews between 15 to 18 foot pounds. Apply a retaining compound such as Loctite 242 to the threads of the capscrew and setscrews. Make sure the threads in the end of shaft and the tapped holes in the pulley hub are free of any oil or grease.

- Remove key from shaft.

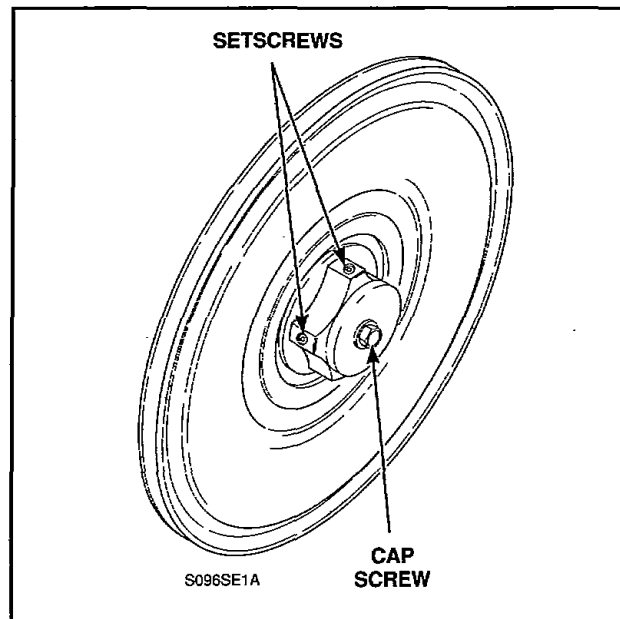

Figure 39

▲ WARNING

To reduce the risk of electric shock, fire, explosion, serious injury or death:

- Disconnect electric power to the washer before servicing.
- Never start the washer with any guards/panels removed.
- Whenever ground wires are removed during servicing, these ground wires must be reconnected to ensure that the washer is properly grounded.

W003

32. CYLINDER ASSEMBLY

- Remove front panel, paragraph 10.
- Remove screws holding rear panel to washer, *Figure 33*.
- Run belt off pulley, *Figure 34*.
- Remove cap screw, lockwasher and flat washer from end of cylinder shaft, *Figure 39*.
- Loosen two setscrews, *Figure 39*, holding pulley and hub assembly to cylinder shaft and pull pulley off shaft.

NOTE: When reinstalling pulley, cap screw should be tightened before tightening the setscrews. Torque the cap screw between 12 to 15 foot pounds and the two setscrews between 15 to 18 foot pounds. Apply a retaining compound such as Loctite 242 to the threads of the capscrew and setscrews. Make sure the threads in the end of shaft and the tapped holes in the pulley hub are free of any oil or grease.

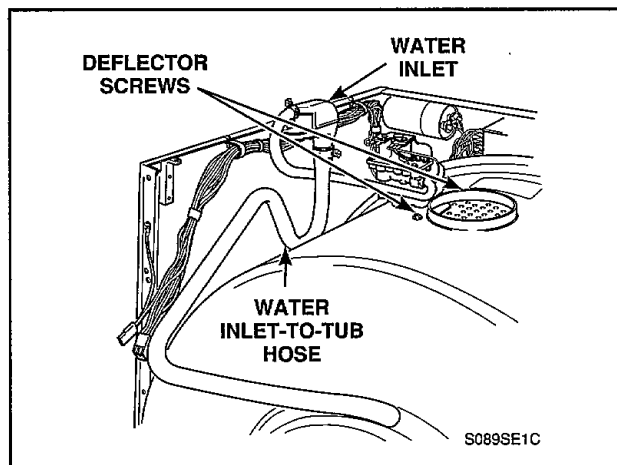

Figure 40

- Remove key from shaft.
- Loosen hose clamp and disconnect water inlet-to-tub hose from water inlet, *Figure 40*, and pressure hose from pressure switch, *Figure 28*.
- Loosen dispenser boot clamp and remove boot from outer tub.
- Remove two screws holding water deflector to outer tub, *Figure 40*, and remove deflector out through dispenser opening.
- Loosen clamps, then remove button trap, *Figure 25*, and drain hose from bottom of outer tub.

NOTE: PUMP MODELS — When installing filter, (if present), the divider in the tub outlet must fit into the slot in the top of the filter assembly, *Figure 26*.

- GRAVITY DRAIN MODELS** — Loosen clamp and disconnect overflow hose from backside of drain valve.
- Remove two screws, nuts, washers and lockwashers holding outer tub to rear support, *Figure 41*.
- Remove two screws, nuts, washers and lockwashers holding outer tub to front support, *Figure 42*.

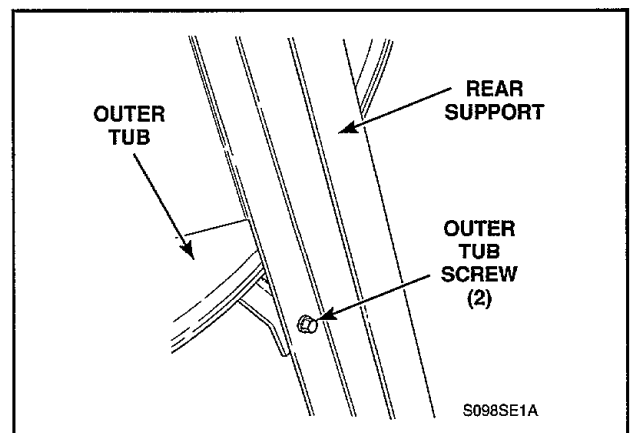

Figure 41

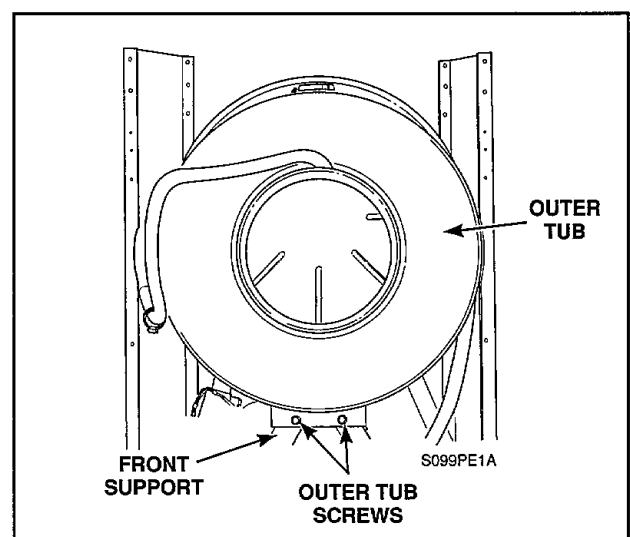

Figure 42

▲ WARNING

To reduce the risk of electric shock, fire, explosion, serious injury or death:

- Disconnect electric power to the washer before servicing.
- Never start the washer with any guards/panels removed.
- Whenever ground wires are removed during servicing, these ground wires must be reconnected to ensure that the washer is properly grounded.

W003

- n. Remove clamp screw, nut and washers holding clamp ring to rear tub head assembly, *Figure 43*.

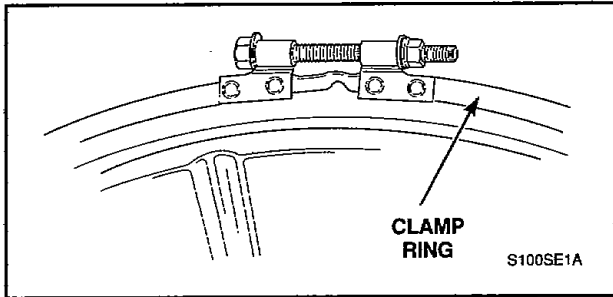

Figure 43

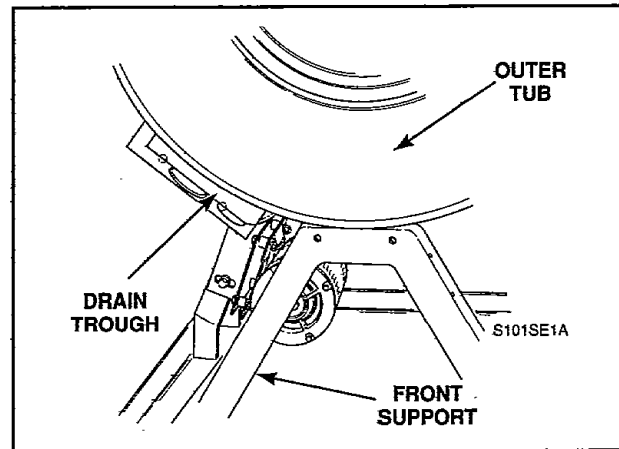

Figure 44

- o. Grasp outer tub at dispenser opening and loading door opening, rotate clockwise far enough for drain trough to clear front support, *Figure 44*, and pull outer tub off cylinder.
- p. Carefully pull cylinder and shaft out of bearing housing.
- q. Remove "O" ring gland, "V" ring seal and two "O" rings from cylinder shaft, *Figure 45*.

IMPORTANT: We recommend installing new "O" rings and "V" ring seal whenever clothes cylinder is removed. Lubricate inside of "O" rings before installing. Care must be taken that "O" rings are not cut or damaged and are in their normal (not inside-out) position when in place. Apply a bead of sealant, such as Dow Corning Silastic 732-RTV or equivalent (these are clear silicone sealants), around the entire area where the "O" ring gland and the rear tub head meet. Then slide the "V" ring seal over the "O" ring gland and up against the rear tub head.

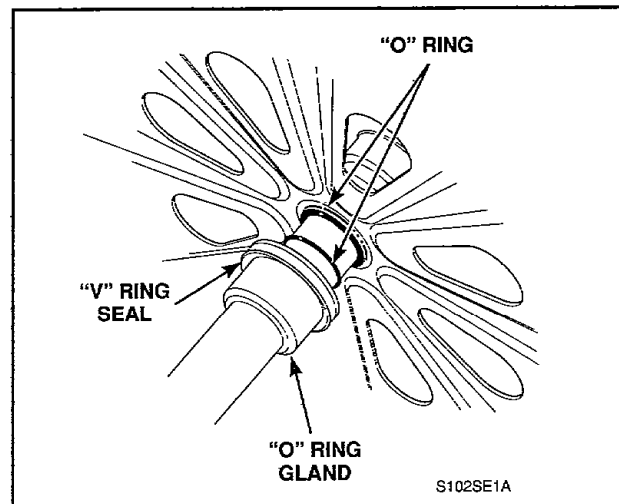

Figure 45

▲ WARNING

To reduce the risk of electric shock, fire, explosion, serious injury or death:

- **Disconnect electric power to the washer before servicing.**
- **Never start the washer with any guards/panels removed.**
- **Whenever ground wires are removed during servicing, these ground wires must be reconnected to ensure that the washer is properly grounded.**

W003

33. REAR TUB HEAD

- a. Remove front panel, paragraph 10.
- b. Remove screws holding rear panel to washer, *Figure 33*.
- c. Run belt off pulley *Figure 34*.
- d. Remove cap screw, lockwasher and flat washer from end of cylinder shaft, *Figure 39*.
- e. Loosen two setscrews, *Figure 39*, holding pulley and hub assembly to cylinder shaft and remove pulley off shaft.

NOTE: When reinstalling pulley, cap screw should be tightened before tightening the setscrews. Torque the cap screw between 12 to 15 foot pounds and the two setscrews between 15 to 18 foot pounds. Apply a retaining compound such as Loctite 242 to the threads of the capscrew and setscrews. Make sure the threads in the end of shaft and the tapped holes in the pulley hub are free of any oil or grease.

- f. Remove key from shaft.
- g. Loosen hose clamp and disconnect water inlet-to-tub hose from water inlet, *Figure 40*, and pressure hose from pressure switch, *Figure 28*.
- h. Loosen dispenser boot clamp and remove boot from outer tub.
- i. Remove two screws holding water deflector to outer tub, *Figure 40*, and remove deflector out through dispenser opening.
- j. Loosen clamps, then remove button trap, *Figure 25*, and drain hose from bottom of outer tub.

NOTE: PUMP MODELS — When installing filter, (if present), the divider in the tub outlet must fit into the slot in the top of the filter assembly, *Figure 26*.

- k. **GRAVITY DRAIN MODELS —** Loosen clamp and disconnect overflow hose from backside of drain valve.
- l. Remove two screws, nuts, washers and lockwashers holding outer tub to rear support, *Figure 41*.

- m. Remove two screws, nuts, washers and lockwashers holding outer tub to front support, *Figure 42*.
- n. Remove clamp screw, nut and washers holding clamp ring to rear tub head assembly, *Figure 43*.
- o. Grasp outer tub at dispenser opening and loading door opening, rotate clockwise far enough for drain trough to clear front support, *Figure 44*, and pull outer tub off cylinder.
- p. Carefully pull cylinder and shaft out of bearing housing.
- q. Remove "O" ring gland, "V" ring seal and two "O" rings from cylinder shaft, *Figure 45*.

IMPORTANT: We recommend installing new "O" rings and "V" ring seal whenever clothes cylinder is removed. Lubricate inside of "O" rings before installing. Care must be taken that "O" rings are not cut or damaged and are in their normal (not inside-out) position when in place. Apply a bead of sealant, such as Dow Corning Silastic 732-RTV or equivalent (these are clear silicone sealants), around the entire area where the "O" ring gland and the rear tub head meet. Then slide the "V" ring seal over the "O" ring gland and up against the rear tub head.

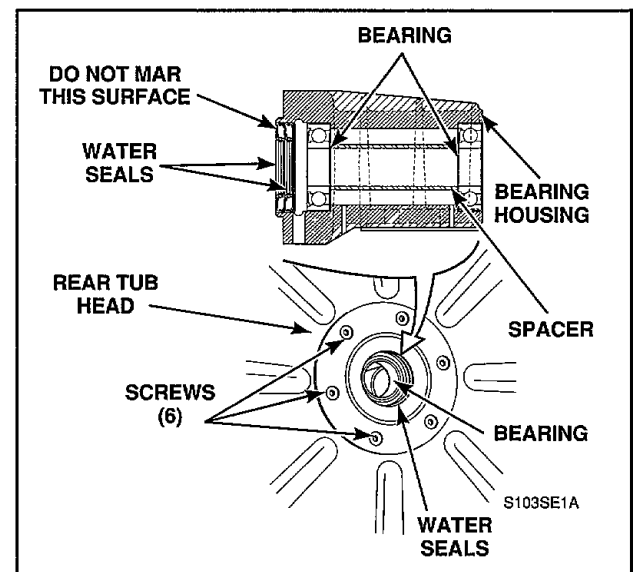

Figure 46

- r. Remove six screws, lockwashers, gasket retainer and gaskets holding rear tub head to bearing housing, *Figure 46*.

▲ WARNING

To reduce the risk of electric shock, fire, explosion, serious injury or death:

- **Disconnect electric power to the washer before servicing.**
- **Never start the washer with any guards/panels removed.**
- **Whenever ground wires are removed during servicing, these ground wires must be reconnected to ensure that the washer is properly grounded.**

W003

34. WATER SEALS

- Remove front panel, paragraph 10.
- Remove screws holding rear panel to washer, *Figure 33*.
- Run belt off pulley, *Figure 34*.
- Remove cap screw, lockwasher and flat washer from end of cylinder shaft, *Figure 39*.
- Loosen two setscrews, *Figure 39*, holding pulley and hub assembly to cylinder shaft and remove pulley off shaft.

NOTE: When reinstalling pulley, cap screw should be tightened before tightening the setscrews. Torque the cap screw between 12 to 15 foot pounds and the two setscrews between 15 to 18 foot pounds. Apply a retaining compound such as Loctite 242 to the threads of the capscrew and setscrews. Make sure the threads in the end of shaft and the tapped holes in the pulley hub are free of any oil or grease.

- Remove key from shaft.
- Loosen hose clamp and disconnect water inlet-to-tub hose from water inlet, *Figure 40*, and pressure hose from pressure switch, *Figure 28*.
- Loosen dispenser boot clamp and remove boot from outer tub.
- Remove two screws holding water deflector to outer tub, *Figure 40*, and remove deflector out through dispenser opening.
- Loosen clamps, then remove button trap, *Figure 25*, and drain hose from bottom of outer tub.

NOTE: PUMP MODELS (Through serial number 9304013231) — When installing filter (if present), the divider in the tub outlet must fit into the slot in the top of the filter assembly, *Figure 26*.

- GRAVITY DRAIN MODELS** — Loosen clamp and disconnect overflow hose from backside of drain valve.
- Remove two screws, nuts, washers and lockwashers holding outer tub to rear support, *Figure 41*.
- Remove two screws, nuts, washers and lockwashers holding outer tub to front support, *Figure 42*.
- Remove clamp screw, nut and washers holding clamp ring to rear tub head assembly, *Figure 43*.
- Grasp outer tub at dispenser opening and loading door opening, rotate clockwise far enough for drain trough to clear front support, *Figure 44*, and pull outer tub off cylinder.
- Carefully pull cylinder and shaft out of bearing housing.
- Remove "O" ring gland, "V" ring seal and two "O" rings from cylinder shaft, *Figure 45*.

IMPORTANT: We recommend installing new "O" rings and "V" ring seal whenever clothes cylinder is removed. Lubricate inside of "O" rings before installing. Care must be taken that "O" rings are not cut or damaged and are in their normal (not inside-out) position when in place. Apply a bead of sealant, such as Dow Corning Silastic 732-RTV or equivalent (these are clear silicone sealants), around the entire area where the "O" ring gland and the rear tub head meet. Then slide the "V" ring over the "O" ring gland and up against the rear tub head.

- Remove six screws, lockwashers, gasket retainer and gaskets holding rear tub head to bearing housing, *Figure 46*.
- Carefully pry water seals out of bearing housing using a pry bar.

NOTE: New seals should be installed with spring loaded lip facing in as shown in *Figure 46*.

IMPORTANT: Be careful when installing second water seal as not to mar the surface where the "V" ring seal contacts the water seal, *Figure 46*.

▲ WARNING

To reduce the risk of electric shock, fire, explosion, serious injury or death:

- Disconnect electric power to the washer before servicing.
- Never start the washer with any guards/panels removed.
- Whenever ground wires are removed during servicing, these ground wires must be reconnected to ensure that the washer is properly grounded.

W003

35. CYLINDER SHAFT BEARING

- Remove front panel, paragraph 10.
- Remove screws holding rear panel to washer, *Figure 33*.
- Run belt off pulley, *Figure 34*.
- Remove cap screw, lockwasher and flat washer from end of cylinder shaft, *Figure 39*.
- Loosen two setscrews, *Figure 39*, holding pulley and hub assembly to cylinder shaft and pull pulley off shaft.

NOTE: When reinstalling pulley, cap screw should be tightened before tightening the setscrews. Torque the cap screw between 12 to 15 foot pounds and the two setscrews between 15 to 18 foot pounds. Apply a retaining compound such as Loctite 242 to the threads of the capscrew and setscrews. Make sure the threads in the end of shaft and the tapped holes in the pulley hub are free of any oil or grease.

- Remove key from shaft.
- Loosen hose clamp and disconnect water inlet-to-tub hose from water inlet, *Figure 31*, and pressure hose from pressure switch, *Figure 28*.
- Loosen dispenser boot clamp and remove boot from outer tub.
- Remove two screws holding water deflector to outer tub, *Figure 40*, and remove deflector out through dispenser opening.
- Loosen clamps, then remove button trap, *Figure 25*, and drain hose from bottom of outer tub.

NOTE: PUMP MODELS (Through serial number 9304013231) — When installing filter (if present), the divider in the tub outlet must fit into the slot in the top of the filter assembly, *Figure 26*.

- GRAVITY DRAIN MODELS** — Loosen clamp and disconnect overflow hose from backside of drain valve.
- Remove two screws, nuts, washers and lockwashers holding outer tub to rear support, *Figure 41*.
- Remove two screws, nuts, washers and lockwashers holding outer tub to front support, *Figure 42*.
- Remove clamp screw, nut and washers holding clamp ring to rear tub head assembly, *Figure 43*.
- Grasp outer tub at dispenser opening and loading door opening, rotate clockwise far enough for drain trough to clear front support, *Figure 44*, and pull outer tub off cylinder.
- Carefully pull cylinder and shaft out of bearing housing.
- Remove "O" ring gland, "V" ring seal and two "O" rings from cylinder shaft, *Figure 45*.

IMPORTANT: We recommend installing new "O" rings and "V" ring seal whenever clothes cylinder is removed. Lubricate inside of "O" rings before installing. Care must be taken that "O" rings are not cut or damaged and are in their normal (not inside-out) position when in place. Apply a bead of sealant, such as Dow Corning Silastic 732-RTV or equivalent (these are clear silicone sealants), around the entire area where the "O" ring gland and the rear tub head meet. Then slide the "V" ring seal over the "O" ring gland and up against the rear tub head.

▲ WARNING

To reduce the risk of electric shock, fire, explosion, serious injury or death:

- **Disconnect electric power to the washer before servicing.**
- **Never start the washer with any guards/panels removed.**
- **Whenever ground wires are removed during servicing, these ground wires must be reconnected to ensure that the washer is properly grounded.**

W003

- r. Remove six screws, lockwashers, gasket retainers and gaskets holding rear tub head to bearing housing, *Figure 46*.
- s. Carefully pry water seals out of bearing housing using a pry bar.

NOTE: Refer to paragraph 34, for proper seal installation.

- t. Drive rear bearing out of rear bearing housing using hammer and hardwood dowel.
- u. Drive front bearing out front of bearing housing using hammer and hardwood dowel.

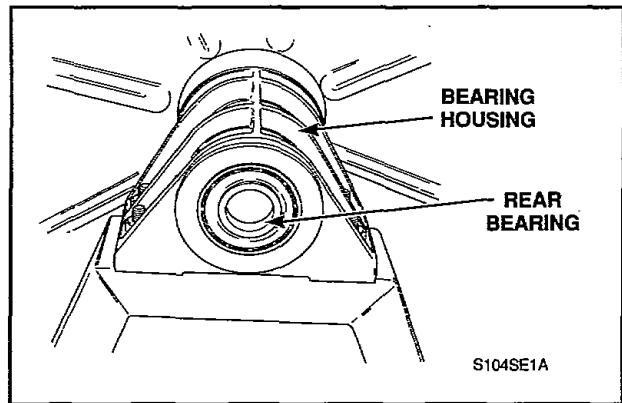

Figure 47

NOTE: When replacing bearings, we recommend installing new water seals as per paragraph 34. Apply a retaining compound (such as Loctite) to outside diameter of bearings. Install bearings with sealed side facing rear tub head, *Figure 46 or 47*.

IMPORTANT: If bearing housing was removed, leave mounting bolts slightly loose while positioning outer tub. This allows proper alignment of cylinder to opening of outer tub. Then tighten bolts firmly (approximately 100 foot pounds - 135.58 N-m).

SECTION II

Adjustments

36. DRIVE BELT

The drive belt requires a number of cycles to achieve its permanent operating position within the pulleys. After 25 to 30 cycles, remove rear panel and recheck belt tension.

▲ WARNING

To reduce the risk of an electrical shock, serious injury or death, disconnect electrical power to washer before performing the following adjustment.

- Remove screws holding rear panel to washer, *Figure 33*.
- Loosen four bolts holding motor mounting bracket to rear tub support, *Figure 48*.
- Move bracket to secure proper belt tension. Proper belt tension is obtained when belt can be deflected approximately 1/2 inch (12.7 mm) from normal position when moderate pressure (5 pounds - 2.25 kg) is applied to a point midway between pulleys.
- After proper belt tension has been obtained, tighten belt adjusting bolts firmly, then tighten pivot bolts, *Figure 48*.

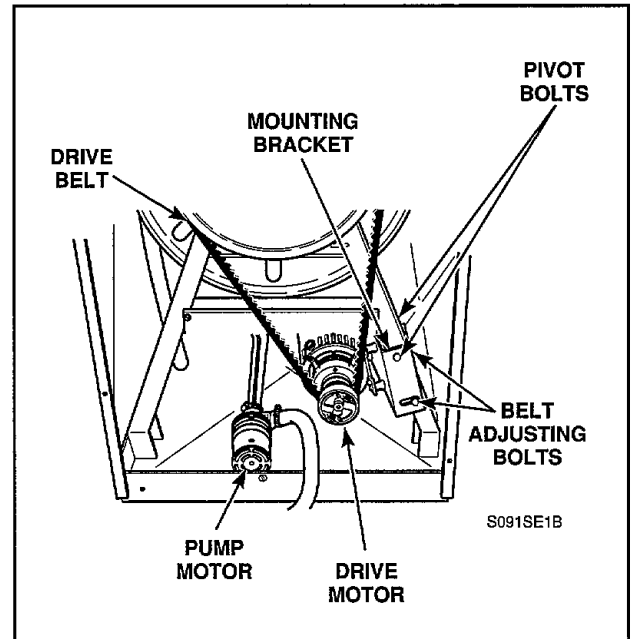

Figure 48

37. PRESSURE SWITCH

NOTE: Do not adjust pressure switch if the washer-extractor is within the warranty period.

The pressure switch is set at the factory for proper water fill levels. If there is a problem of overfilling or underfilling, check the water depth in the cylinder. At the end of the fill portion, water depth should be approximately 4-1/2 inches (1.43 cm), *Figure 49*. (Measure water depth with no clothes in cylinder.)

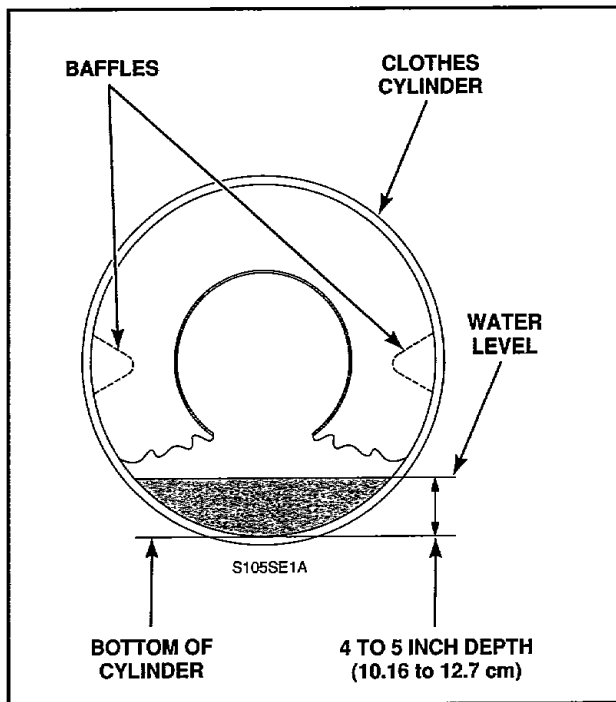

Figure 49

The pressure switch can be adjusted as follows:

▲ WARNING

To reduce the risk of an electrical shock, or serious injury or death, disconnect electrical power to washer before performing the following adjustment.

- a. **METERED MODELS** — Unlock accumulator coin drop and pull out of washer as far as wires will permit, *Figure 2*.

NOTE: Lock is threaded and will require several counterclockwise turns to unlock.

NONMETERED MODELS — Remove the hex head screw and pull start switch out of washer as far as wires will permit, *Figure 1*.

- b. Disconnect the coin drop or start switch wire harness at the quick disconnect blocks.
- c. Remove the three screws holding control panel assembly to cabinet top, *Figure 4*.
- d. Tilt control panel assembly away from washer and disconnect wire harness at disconnect blocks, then remove control panel assembly.
- e. Open dispenser door, compress dispenser boot and push boot down through cabinet top, *Figure 12*.
- f. Remove two cabinet top hold-down screws, *Figure 13*.
- g. Tilt cabinet top back and hold in raised position with a small chain, *Figure 14*.
- h. Remove sealer from around pressure switch adjusting screw, *Figure 50*.

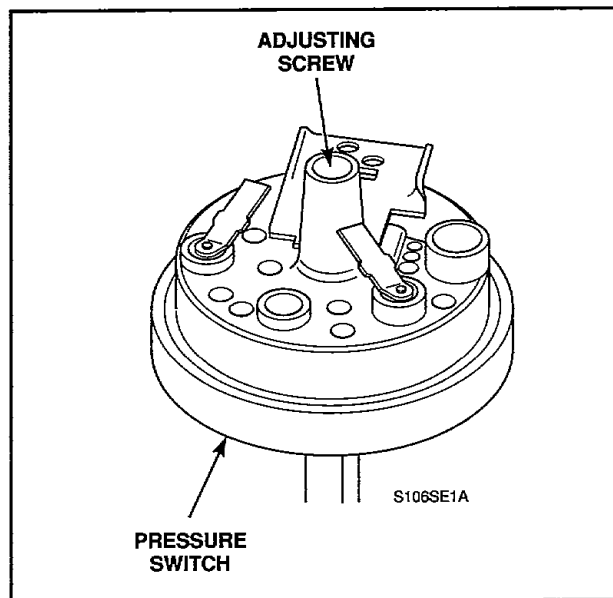

Figure 50

- i. Turn adjusting screw, *Figure 50*, **clockwise** to increase water level in clothes cylinder, or **counterclockwise** to decrease water level.

NOTE: 1/4 turn of adjusting screw represents approximately one inch (2.54 cm) increase or decrease of water level in clothes cylinder.

IMPORTANT: DO NOT turn adjusting screw more than 3/4 of a turn in either direction.

38. DOOR LOCK ASSEMBLY

IMPORTANT: Before making switch adjustment, make sure door handle and latch are aligned, and setscrew (in door handle) is tight.

- a. **METERED MODELS** — Unlock accumulator coin drop and pull out of washer as far as wires will permit, *Figure 2*.

NOTE: Lock is threaded and will require several counterclockwise turns to unlock.

NONMETERED MODELS — Remove the hex head screw and pull start switch out of washer as far as wires will permit, *Figure 1*.

- b. Disconnect the coin drop or start switch wire harness at the quick disconnect blocks.
- c. Remove the three screws holding control panel assembly to cabinet top, *Figure 4*.
- d. Tilt control panel assembly away from washer and disconnect wire harness at disconnect blocks, then remove control panel assembly.
- e. Remove four screws holding lower front panel to washer base, *Figure 8*.
- f. Pull bottom of panel away from washer, lower panel, then remove panel from washer.

NOTE: PUMP MODELS — When lower front panel is reinstalled, end of overflow hose must protrude through hole in bottom of panel, *Figure 8*.

- g. Open dispenser door, compress dispenser boot and push boot down through cabinet top, *Figure 12*.
- h. Remove two cabinet top hold-down screws, *Figure 13*.
- i. Tilt cabinet top back and hold in raised position with a small chain, *Figure 14*.
- j. **METERED MODELS** — Unlock and remove coin drawer; then remove flathead screw and locknut holding coin vault to front panel, *Figure 16*, then remove two cap screws and lockwashers holding coin vault to right leg, *Figure 16*.
- k. Remove two nuts and lockwashers, *Figure 17*, holding front panel assembly to left leg (leave bolts in place).
- l. Remove nut and lockwasher (bottom), and capscrew (top), *Figure 18*, holding front panel assembly to right leg.

NOTE: PUMP MODELS — Overflow hose, *Figure 16*, may have to be pushed down to gain access to cap screw holding top of front panel assembly to right leg.

- m. Disconnect door lock wire harness at disconnect blocks.
- n. Disengage door seal from front panel flange, *Figure 19*.
- o. Carefully remove front panel assembly from washer.

IMPORTANT: When reinstalling front panel assembly, leave bolts loose until the door seal is properly positioned and the door opening is centered with the outer tub when loading door is in the closed position.

DOOR SAFETY SWITCH

▲ WARNING

To reduce the risk of an electrical shock, disconnect electrical power unless power supply is required to perform this adjustment procedure.

IMPORTANT: Before making switch adjustment, make sure door handle and pivot arm are aligned, and setscrew (in door handle) is tight.

- a. Loosen door safety switch attaching screws, *Figure 51*.

NOTE: Switch screws must be tight enough to hold switch in position on door lock bracket.

- b. Apply electrical power to the thermoactuator until plunger is fully extended.
- c. Disconnect electrical power to thermoactuator, plunger will retract in approximately 1 to 3 minutes. During this time, pivot the door safety switch so the switch contacts reset (click) with a 1/16 inch clearance between the door lock latch and door lock block, *Figure 51*.
- d. Without moving the switch, tighten the nut on adjusting screw, then tighten pivot screw, *Figure 51*.

NOTE: Torque adjusting screw to a maximum of 12 inch pounds and the pivot screw to a maximum of 15 inch pounds.

- e. Repeat steps "b" and "c" to make sure the reset point has not changed.

IMPORTANT: If tightening the switch screws (as mentioned in step "d" affects the switch actuation or reset points of the switch, DO NOT reuse the switch, it should be replaced with another switch.

DOOR LOCK SWITCH

▲ WARNING

To reduce the risk of an electrical shock, disconnect electrical power unless power supply is required to perform this adjustment procedure.

IMPORTANT: Before making switch adjustment, make sure door handle and pivot arm are aligned, and setscrew (in door handle) is tight.

- a. Loosen door switch attaching screws, *Figure 51*.

NOTE: Switch screws must be tight enough to hold switch in position on door lock bracket.

- b. Close loading door and latch the door handle.
- c. Apply electrical power to the thermoactuator until plunger is fully extended.
- d. Disconnect electrical power to thermoactuator, plunger will retract in approximately 1 to 3 minutes. During this time, with the door closed and the handle latched, pivot the door lock switch so the switch contacts close (click) with a 1/16 inch clearance between the pivot arm and the door lock latch, *Figure 51*.
- e. Without moving the switch, tighten the nut on the adjusting screw, then tighten pivot screw, *Figure 51*.

NOTE: Torque adjusting screw to a maximum of 12 inch pounds and the pivot screw to a maximum of 15 inch pounds.

- f. Repeat steps "c" and "d" to make sure the closing point has not changed.

IMPORTANT: If tightening the switch screws (as mentioned in step "e") affects the switch actuation or closing points of the switch, DO NOT reuse the switch, it should be replaced with another switch.

THERMOACTUATOR

▲ WARNING

To reduce the risk of an electrical shock, disconnect electrical power unless power supply is required to perform this adjustment procedure.

- a. Loosen thermoactuator attaching screws, *Figure 51*.

NOTE: Screws must be tight enough to hold thermoactuator in position on door lock bracket.

- b. Apply electrical power to thermoactuator until plunger is fully extended.
- c. Disconnect electrical power to thermoactuator, plunger will retract in approximately 1-1/2 to 3 minutes. During this time, position the thermoactuator so there is a clearance of 1/64 inch between the outer end of the linkage and the door lock block.

IMPORTANT: Thermoactuator linkage must not touch the door lock block when the plunger is fully extended because damage could result to the thermoactuator.

- d. After proper adjustment is made and without moving the thermoactuator, tighten the two screws firmly.

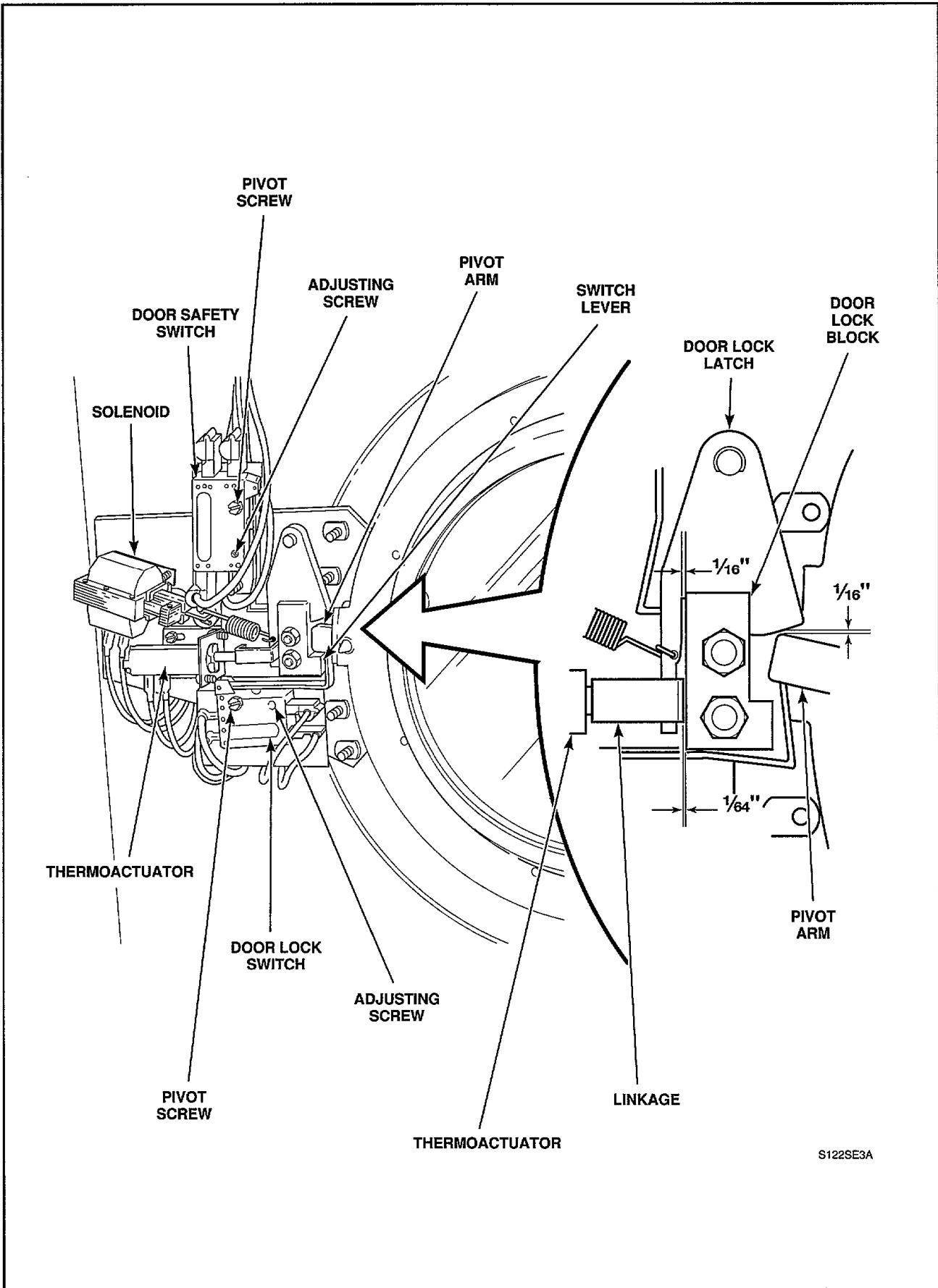

Figure 51

SECTION III

Test Procedures

▲ WARNING

To reduce the risk of electric shock, fire, explosion, serious injury or death:

- Disconnect electric power to the washer before servicing.
- Never start the washer with any guards/panels removed.
- Whenever ground wires are removed during servicing, these ground wires must be reconnected to ensure that the washer is properly grounded.

W003

NOTE: The following test procedures will concern both voltage and continuity checks.

▲ WARNING

To reduce the risk of an electrical shock, serious injury or death, have the voltage checks performed by a qualified electrician or by yourself only if you understand and have the skills to perform safely.

Voltage checks are taken by setting the meter on a Voltage AC scale that is higher than the expected reading. These voltage checks MUST be done while the washer-extractor is operating. Components must be checked while they are normally energized during the cycle.

▲ WARNING

To reduce the risk of an electrical shock, serious injury or death, disconnect electric power to the washer before performing the continuity checks.

Continuity checks are taken by setting the meter on an Ohms scale. The washer MUST be shut off and the electrical power to the washer MUST be disconnected. When making a continuity check, always disconnect at least one wire to any two points being checked.

IMPORTANT: Electrical test procedures in this manual are performed using a Volt-Ohm meter. Test can also be performed using a multimeter or any other electrical testing equipment with which the service person is familiar.

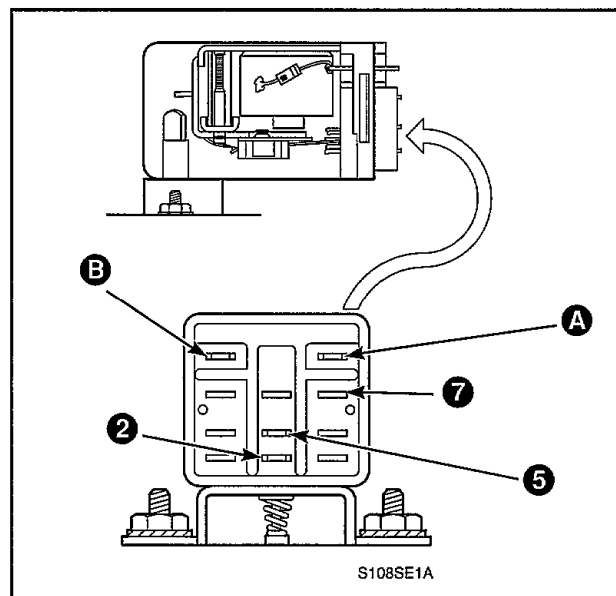

Figure 52

39. START SWITCH — NONMETERED MODELS

- Remove start switch, paragraph 1.
- Disconnect wires from switch terminals.

NOTE: Refer to wiring diagram when rewiring switch.

IMPORTANT: Before making the following test, momentarily push switch button in to reset switch.

- For continuity check, place meter probes to terminal No. 7 (common) and to terminal No. 2 (normally closed), *Figure 52*.
- Reset switch contacts by momentarily engaging solenoid. For continuity check, place meter probes to terminal No. 7 (common) and to terminal No. 5 (normally open), *Figure 52*.
- SOLENOID** — For voltage check, place meter probes to solenoid terminals "A" and "B", meter should read 120 Volts when softener light comes on, *Figure 52*. For continuity check, meter should read approximately 1800 Ohms plus or minus ten percent.

▲ WARNING

To reduce the risk of electric shock, fire, explosion, serious injury or death:

- **Disconnect electric power to the washer before servicing.**
- **Never start the washer with any guards/panels removed.**
- **Whenever ground wires are removed during servicing, these ground wires must be reconnected to ensure that the washer is properly grounded.**

W003

40. INDICATOR LIGHTS

- a. **METERED MODELS** — Unlock accumulator coin drop and pull out of washer as far as wires will permit, *Figure 2*.

NOTE: Lock is threaded and will require several **counterclockwise** turns to unlock.

NONMETERED MODELS — Remove the hex head screw and pull start switch out of washer as far as wires will permit, *Figure 1*.

- b. Disconnect the coin drop or start switch wire harness at the quick disconnect blocks.
- c. Remove the three screws holding control panel assembly to cabinet top, *Figure 4*.
- d. Tilt control panel assembly away from washer and disconnect wire harness at disconnect blocks, then remove control panel assembly.

- e. For voltage check, place one meter probe on the colored wire, leading to the light and the other probe to a known ground. If meter reads 120 Volts but light does not glow, replace the light.

NOTE: This check must be done when the light is normally lit during the check. Refer to wiring diagram.

▲ WARNING

To reduce the risk of electric shock, fire, explosion, serious injury or death:

- **Disconnect electric power to the washer before servicing.**
- **Never start the washer with any guards/panels removed.**
- **Whenever ground wires are removed during servicing, these ground wires must be reconnected to ensure that the washer is properly grounded.**

W003

41. WASH TEMPERATURE SWITCH

- a. **METERED MODELS** — Unlock accumulator coin drop and pull out of washer as far as wires will permit, *Figure 2*.

NOTE: Lock is threaded and will require several counterclockwise turns to unlock.

NONMETERED MODELS — Remove the hex head screw and pull start switch out of washer as far as wires will permit, *Figure 1*.

- b. Disconnect the coin drop or start switch wire harness at the quick disconnect blocks.
 c. Remove the three screws holding control panel assembly to cabinet top, *Figure 4*.
 d. Tilt control panel assembly away from washer and disconnect wire harness at disconnect blocks, then remove control panel assembly.
 e. Disconnect wires from switch.

NOTE: Refer to wiring diagram when rewiring switch.

- f. Apply meter probes to terminals indicated in *Figure 53*.

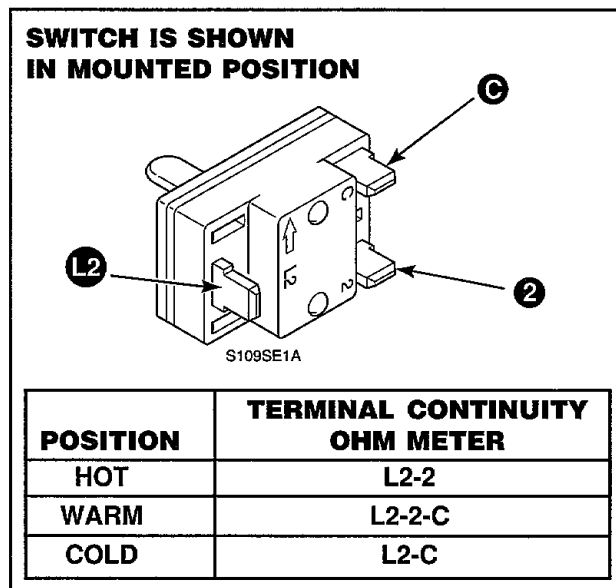

Figure 53

42. ACTION SWITCH

- a. **METERED MODELS** — Unlock accumulator coin drop and pull out of washer as far as wires will permit, *Figure 2*.

NOTE: Lock is threaded and will require several counterclockwise turns to unlock.

NONMETERED MODELS — Remove the hex head screw and pull start switch out of washer as far as wires will permit, *Figure 1*.

- b. Disconnect the coin drop or start switch wire harness at the quick disconnect blocks.
 c. Remove the three screws holding control panel assembly to cabinet top, *Figure 4*.
 d. Tilt control panel assembly away from washer and disconnect wire harness at disconnect blocks, then remove control panel assembly.
 e. Disconnect wires from switch.

NOTE: Refer to wiring diagram when rewiring switch.

- f. Apply meter probes to terminals indicated in *Figure 54* for continuity checks.

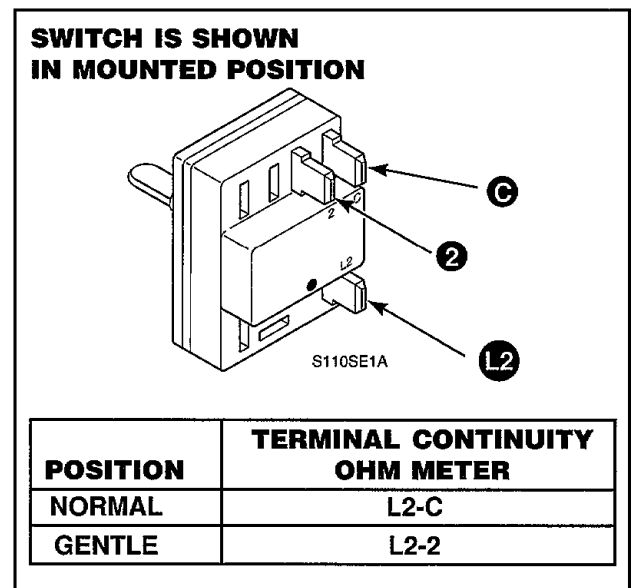

Figure 54

▲ WARNING

To reduce the risk of electric shock, fire, explosion, serious injury or death:

- Disconnect electric power to the washer before servicing.
- Never start the washer with any guards/panels removed.
- Whenever ground wires are removed during servicing, these ground wires must be reconnected to ensure that the washer is properly grounded.

W003

43. DOOR LOCK ASSEMBLY (Refer to Figure 55)

NOTE: The following checks are made by removing the control panel and disconnecting the harness at the Molex plug. However, the assembly can be removed and each component checked separately.

- a. **DOOR LOCK SOLENOID** — For continuity check, apply meter probes to WHITE and PINK wires at Molex plug, meter should read approximately 120 Ohms.
- b. **DOOR LOCK AND SAFETY SWITCH** — For continuity check, apply meter probes to YELLOW and ORANGE wires at Molex plug, meter should read a closed circuit with the door closed.
- c. **DOOR LOCK AND SAFETY SWITCH** — For continuity check, apply meter probes to RED and BLUE wires at Molex plug, meter should read a closed circuit with the door closed.

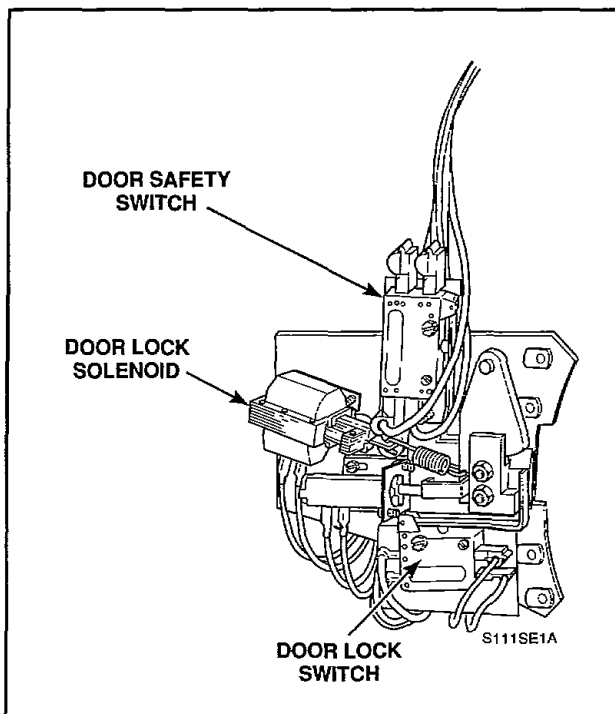

Figure 55

44. PRESSURE SWITCH (Refer to Figure 56)

- a. **METERED MODELS** — Unlock accumulator coin drop and pull out of washer as far as wires will permit, Figure 2.

NOTE: Lock is threaded and will require several counterclockwise turns to unlock.

NONMETERED MODELS — Remove the hex head screw and pull start switch out of washer as far as wires will permit, Figure 1.

- b. Disconnect the coin drop or start switch wire harness at the quick disconnect blocks.
- c. Remove the three screws holding control panel assembly to cabinet top, Figure 4.
- d. Tilt control panel assembly away from washer and disconnect wire harness at disconnect blocks, then remove control panel assembly.
- e. Open dispenser door, compress dispenser boot and push boot down through cabinet top, Figure 12.
- f. Remove two cabinet top hold-down screws, Figure 13.
- g. Tilt cabinet top back and hold in raised position with a small chain, Figure 14.
- h. Attach a short length of hose to pressure switch.
- i. For continuity check, apply meter probes to terminals on pressure switch, meter reading should be a closed circuit.
- j. Blow gently into hose until a distinct "click" is heard, meter should not read an open circuit.

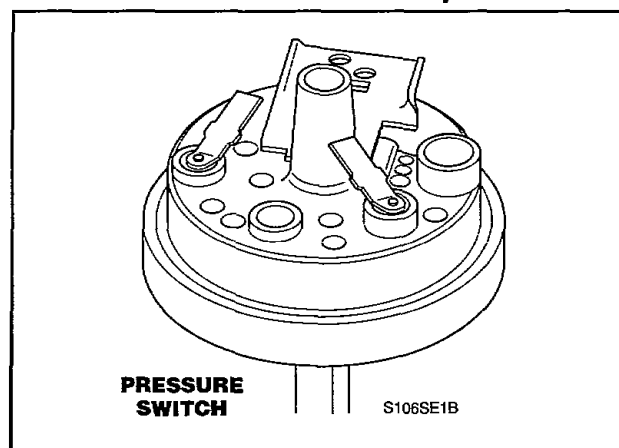

Figure 56

▲ WARNING

To reduce the risk of electric shock, fire, explosion, serious injury or death:

- **Disconnect electric power to the washer before servicing.**
- **Never start the washer with any guards/panels removed.**
- **Whenever ground wires are removed during servicing, these ground wires must be reconnected to ensure that the washer is properly grounded.**

W003

45. MOTOR RELAY (Refer to Figure 57)

- a. **METERED MODELS** — Unlock accumulator coin drop and pull out of washer as far as wires will permit, *Figure 2*.

NOTE: Lock is threaded and will require several counterclockwise turns to unlock.

NONMETERED MODELS — Remove the hex head screw and pull start switch out of washer as far as wires will permit, *Figure 1*.

- b. Disconnect the coin drop or start switch wire harness at the quick disconnect blocks.
- c. Remove the three screws holding control panel assembly to cabinet top, *Figure 4*.
- d. Tilt control panel assembly away from washer and disconnect wire harness at disconnect blocks, then remove control panel assembly.
- e. Open dispenser door, compress dispenser boot and push boot down through cabinet top, *Figure 12*.
- f. Remove two cabinet top hold-down screws, *Figure 13*.
- g. Tilt cabinet top back and hold in raised position with a small chain, *Figure 14*.
- h. Disconnect wires from relay.

NOTE: Refer to wiring diagram when rewiring relay.

- i. **COIL** — For continuity check, place meter probes to terminals "A" and "B".

NOTE: The relay is a double pole, double throw relay.

- j. For continuity check and with coil de-energized, place meter probes to terminal No. 7 (common) and to terminal No. 1 (normally closed). Then place meter probes to terminal No. 9 (common) and to terminal No. 3 (normally closed).
- k. For continuity check and with coil energized, place meter probes to terminal No. 7 (common) and to terminal No. 4 (normally open). Then place meter probes to terminal No. 9 (common) and to terminal No. 6 (normally open).

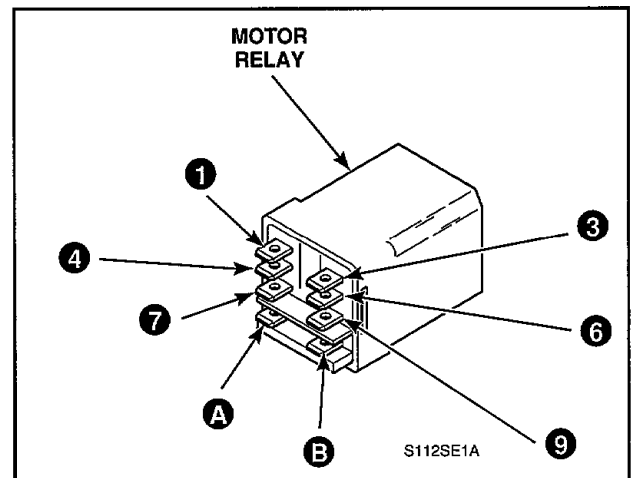

Figure 57

▲ WARNING

To reduce the risk of electric shock, fire, explosion, serious injury or death:

- **Disconnect electric power to the washer before servicing.**
- **Never start the washer with any guards/panels removed.**
- **Whenever ground wires are removed during servicing, these ground wires must be reconnected to ensure that the washer is properly grounded.**

W003

46. CAPACITOR

- a. **METERED MODELS** — Unlock accumulator coin drop and pull out of washer as far as wires will permit, *Figure 2*.

NOTE: Lock is threaded and will require several counterclockwise turns to unlock.

NONMETERED MODELS — Remove the hex head screw and pull start switch out of washer as far as wires will permit, *Figure 1*.

- b. Disconnect the coin drop or start switch wire harness at the quick disconnect blocks.
- c. Remove the three screws holding control panel assembly to cabinet top, *Figure 4*.
- d. Tilt control panel assembly away from washer and disconnect wire harness at disconnect blocks, then remove control panel assembly.
- e. Open dispenser door, compress dispenser boot and push boot down through cabinet top, *Figure 12*.
- f. Remove two cabinet top hold-down screws, *Figure 13*.
- g. Tilt cabinet top back and hold in raised position with a small chain, *Figure 14*.
- h. Check capacitor visually for ruptures or corrosion.
- i. Discharge capacitor by shorting across terminals with an insulated screwdriver.
- j. Remove wires and resistor from capacitor.
- k. For continuity test, set meter in highest scale and apply probes to capacitor terminals. Needle on meter should read closed circuit initially and slowly return back to an open circuit reading.
- l. For continuity check, apply one meter probe to capacitor casing and the other to each terminal, all readings should be open.
- m. **RESISTOR** — For continuity check, apply meter probes to resistor terminals, meter should read approximately 220,000 Ohms.

▲ WARNING

To reduce the risk of electric shock, fire, explosion, serious injury or death:

- **Disconnect electric power to the washer before servicing.**
- **Never start the washer with any guards/panels removed.**
- **Whenever ground wires are removed during servicing, these ground wires must be reconnected to ensure that the washer is properly grounded.**

W003

47. CYCLE TIMER

- a. **METERED MODELS** — Unlock accumulator coin drop and pull out of washer as far as wires will permit, *Figure 2*.

NOTE: Lock is threaded and will require several counterclockwise turns to unlock.

NONMETERED MODELS — Remove the hex head screw and pull start switch out of washer as far as wires will permit, *Figure 1*.

- b. Disconnect the coin drop or start switch wire harness at the quick disconnect blocks.
 c. Remove the three screws holding control panel assembly to cabinet top, *Figure 4*.

- d. Tilt control panel assembly away from washer and disconnect wire harness at disconnect blocks, then remove control panel assembly.
 e. Open dispenser door, compress dispenser boot and push boot down through cabinet top, *Figure 12*.
 f. Remove two cabinet top hold-down screws, *Figure 13*.
 g. Tilt cabinet top back and hold in raised position with a small chain, *Figure 14*.
 h. Disconnect wires from timer terminals.

NOTE: Refer to wiring diagram when rewiring timer.

- i. Apply meter probes to timer terminals indicated in *Figure 58* for continuity check.

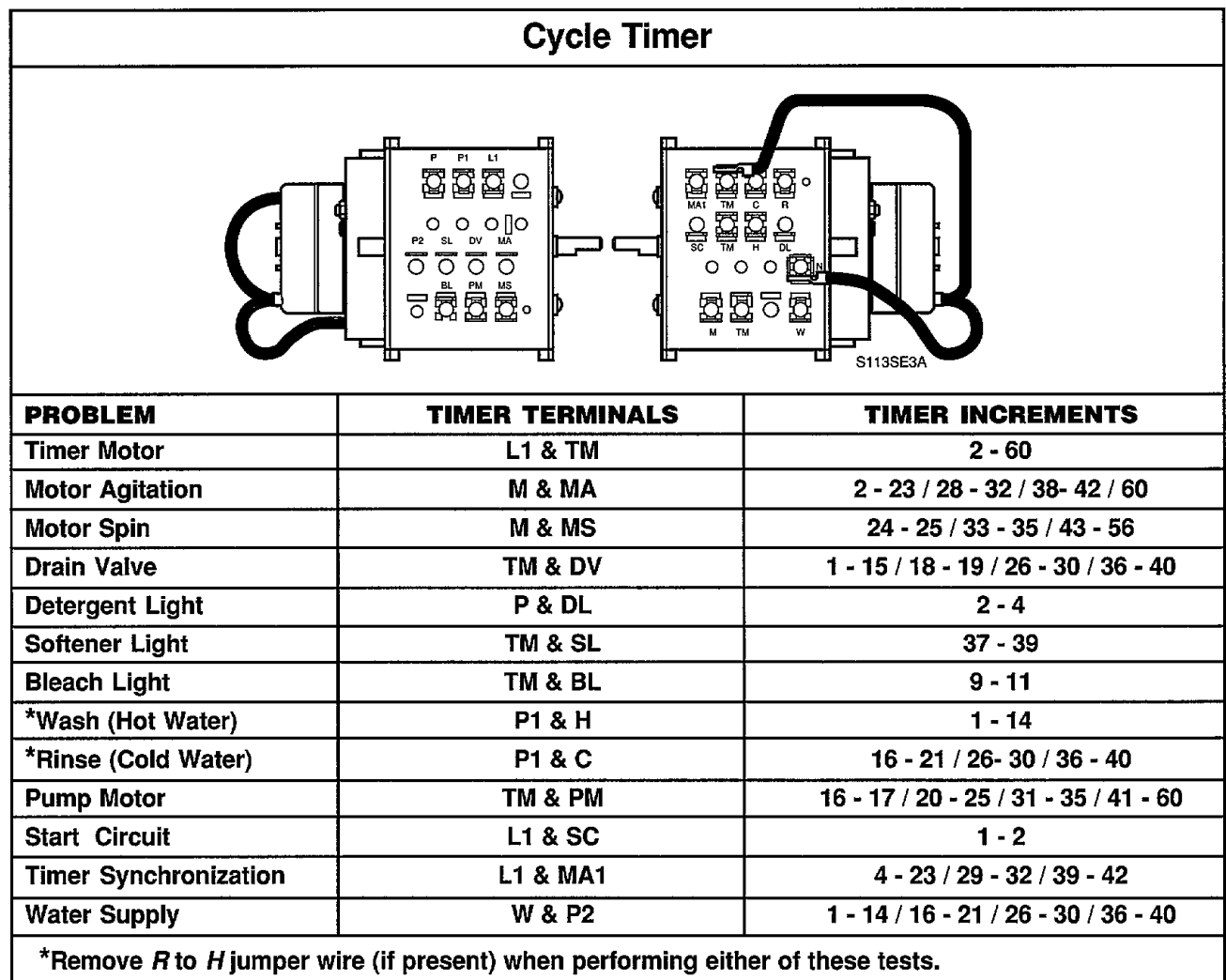

Figure 58

▲ WARNING

To reduce the risk of electric shock, fire, explosion, serious injury or death:

- **Disconnect electric power to the washer before servicing.**
- **Never start the washer with any guards/panels removed.**
- **Whenever ground wires are removed during servicing, these ground wires must be reconnected to ensure that the washer is properly grounded.**

W003

48. REVERSING TIMER

- a. **METERED MODELS** — Unlock accumulator coin drop and pull out of washer as far as wires will permit, *Figure 2*.

NOTE: Lock is threaded and will require several counterclockwise turns to unlock.

NONMETERED MODELS — Remove the hex head screw and pull start switch out of washer as far as wires will permit, *Figure 1*.

- b. Disconnect the coin drop or start switch wire harness at the quick disconnect blocks.
 c. Remove the three screws holding control panel assembly to cabinet top, *Figure 4*.
 d. Tilt control panel assembly away from washer and disconnect wire harness at disconnect blocks, then remove control panel assembly.

- e. Open dispenser door, compress dispenser boot and push boot down through cabinet top, *Figure 12*.
 f. Remove two cabinet top hold-down screws, *Figure 13*.
 g. Tilt cabinet top back and hold in raised position with a small chain, *Figure 14*.
 h. Disconnect wires from timer terminals.

NOTE: Refer to wiring diagram when rewiring timer.

- i. Apply meter probes to timer terminals indicated in *Figure 59* for continuity check.

NOTE: During the agitation portion of the cycle, the center screw should revolve once every two minutes.

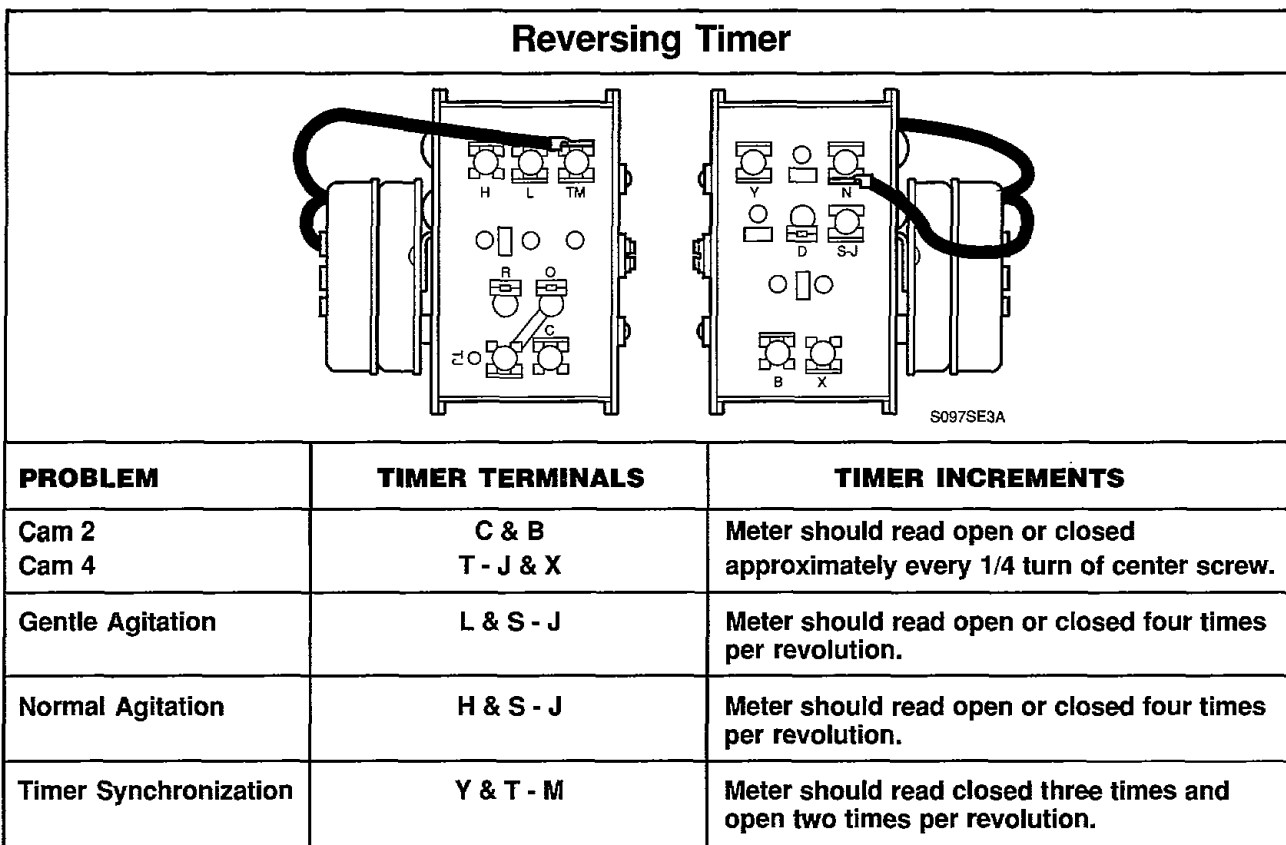

Figure 59

▲ WARNING

To reduce the risk of electric shock, fire, explosion, serious injury or death:

- **Disconnect electric power to the washer before servicing.**
- **Never start the washer with any guards/panels removed.**
- **Whenever ground wires are removed during servicing, these ground wires must be reconnected to ensure that the washer is properly grounded.**

W003

49. TIMER MOTOR (Cycle or Reversing Timer)

- a. **METERED MODELS** — Unlock accumulator coin drop and pull out of washer as far as wires will permit, *Figure 2*.

NOTE: Lock is threaded and will require several counterclockwise turns to unlock.

NONMETERED MODELS — Remove the hex head screw and pull start switch out of washer as far as wires will permit, *Figure 1*.

- b. Disconnect the coin drop or start switch wire harness at the quick disconnect blocks.
- c. Remove the three screws holding control panel assembly to cabinet top, *Figure 4*.
- d. Tilt control panel assembly away from washer and disconnect wire harness at disconnect blocks, then remove control panel assembly.
- e. Open dispenser door, compress dispenser boot and push boot down through cabinet top, *Figure 12*.
- f. Remove two cabinet top hold-down screws, *Figure 13*.
- g. Tilt cabinet top back and hold in raised position with a small chain, *Figure 14*.
- h. Disconnect wires from timer terminals.

NOTE: Refer to wiring diagram when rewiring timer.

- i. For continuity check, apply meter probes to each timer motor wire terminals, meter should read approximately 3,000 Ohms.
- j. Apply live power to timer motor wire terminals, timer motor should run.

50. MIXING VALVE SOLENOID

- a. **METERED MODELS** — Unlock accumulator coin drop and pull out of washer as far as wires will permit, *Figure 2*.

NOTE: Lock is threaded and will require several counterclockwise turns to unlock.

NONMETERED MODELS — Remove the hex head screw and pull start switch out of washer as far as wires will permit, *Figure 1*.

- b. Disconnect the coin drop or start switch wire harness at the quick disconnect blocks.
- c. Remove the three screws holding control panel assembly to cabinet top, *Figure 4*.
- d. Tilt control panel assembly away from washer and disconnect wire harness at disconnect blocks, then remove control panel assembly.
- e. Open dispenser door, compress dispenser boot and push boot down through cabinet top, *Figure 12*.
- f. Remove two cabinet top hold-down screws, *Figure 13*.
- g. Tilt cabinet top back and hold in raised position with a small chain, *Figure 14*.
- h. Disconnect wires from timer terminals.

NOTE: Refer to appropriate wiring diagram when rewiring solenoids.

- i. For voltage check, apply meter probes to solenoid terminals, meter should read 120 Volts.
- j. For continuity check, apply meter probes to solenoid terminals, meter should read approximately 600 Ohms.

▲ WARNING

To reduce the risk of electric shock, fire, explosion, serious injury or death:

- **Disconnect electric power to the washer before servicing.**
- **Never start the washer with any guards/panels removed.**
- **Whenever ground wires are removed during servicing, these ground wires must be reconnected to ensure that the washer is properly grounded.**

W003

51. PUMP MOTOR (Refer to *Figure 60*)

- Remove rear panel *Figure 33*.
- Disconnect motor wire leads at connectors.
- For voltage check, apply meter probes to motor leads, meter should read 120 Volts.
- For continuity check, apply meter probes to motor leads, meter should read approximately 4 Ohms.

52. DRIVE MOTOR (Refer to *Figure 60*)

- Remove rear panel, *Figure 33*.
- Disconnect motor wire harness at disconnect blocks.

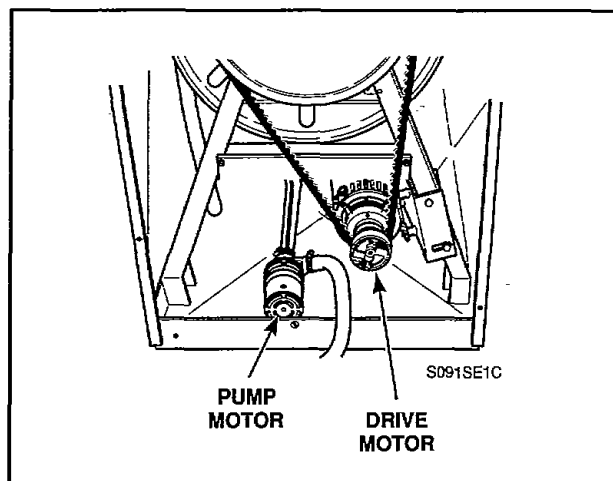

Figure 60

NOTE: Number 81691 Service Harness is available for checking out the motor. Use it **ONLY** with an adjacent Superload II Washer-Extractor known to be in working order.

SECTION IV

Service Helps

▲ WARNING

To reduce the risk of electric shock, fire, explosion, serious injury or death:

- **Disconnect electric power to the washer before servicing.**
- **Never start the washer with any guards/panels removed.**
- **Whenever ground wires are removed during servicing, these ground wires must be reconnected to ensure that the washer is properly grounded.**

W003

53. WASHER DOES NOT START

POSSIBLE CAUSE	TO CORRECT
Electric power disconnected or fuse blown.	Connect electrical power or replace fuse.
Inoperative start switch (Nonmetered Models).	Test start switch, paragraph 39, and replace if inoperative, paragraph 1.
Accumulator Coin Drop (Metered Models) Coin drop does not accept coins. 1. Inoperative coin switch. 2. Bent coin switch trip wire.	Check out accumulator coin drop.
Improperly adjusted door lock switch.	Adjust switch, paragraph 38.
Inoperative door lock switch.	Test switch, paragraph 43, and replace if inoperative, paragraph 13.
Improperly adjusted door safety switch.	Adjust switch, paragraph 38.
Inoperative door safety switch.	Test switch, paragraph 43, and replace if inoperative, paragraph 13.
Inoperative cycle timer.	Test timer start circuit, paragraph 47, and replace if inoperative.
Broken, loose or incorrect wiring.	Refer to appropriate wiring diagram.

54. CYLINDER DOES NOT FILL

POSSIBLE CAUSE	TO CORRECT
No hot water.	Refer to paragraph 55.
No cold water.	Refer to paragraph 56.
Inoperative pressure switch.	Test switch, paragraph 44, and replace if inoperative, paragraph 18.
Improperly adjusted pressure switch.	Adjust switch, paragraph 37.
Inoperative cycle timer.	Test timer, paragraph 47, and replace if inoperative, paragraph 20.
Obstruction in drain valve.	Clean valve, <i>Figure 27</i> .
Broken, loose or incorrect wiring.	Refer to appropriate wiring diagram.

▲ WARNING

To reduce the risk of electric shock, fire, explosion, serious injury or death:

- **Disconnect electric power to the washer before servicing.**
- **Never start the washer with any guards/panels removed.**
- **Whenever ground wires are removed during servicing, these ground wires must be reconnected to ensure that the washer is properly grounded.**

W003

55. NO HOT WATER

POSSIBLE CAUSE	TO CORRECT
Water in hot water tank is cold.	Check hot water source.
Hot water supply line closed.	Check for closed valve, kinked hose or obstruction in line.
Clogged water mixing valve inlet screen.	Remove and clean or replace screen, <i>Figure 30</i> .
WASH TEMPERATURE switch improperly set or inoperative.	Set switch or test switch, paragraph 41, and replace if inoperative.
Inoperative hot water solenoid.	Test solenoid, paragraph 50, and replace if inoperative, paragraph 22, <i>Figure 30</i> .
Broken, loose or incorrect wiring.	Refer to appropriate wiring diagram.

56. NO COLD WATER

POSSIBLE CAUSE	TO CORRECT
Cold water supply line closed.	Check for closed valve, kinked hose or obstruction in line.
Clogged water mixing valve inlet screen.	Remove and clean, or replace screens, <i>Figure 30</i> .
WASH TEMPERATURE switch improperly set or inoperative.	Set switch or test switch, paragraph 41, and replace if inoperative.
Inoperative cold water solenoid.	Test solenoid, paragraph 50, and replace if inoperative, paragraph 22, <i>Figure 30</i> .
Inoperative cycle timer.	Test timer, paragraph 47, and replace if inoperative, paragraph 20.
Broken, loose or incorrect wiring.	Refer to appropriate wiring diagram.

57. NO WARM WATER

POSSIBLE CAUSE	TO CORRECT
No hot water.	Refer to paragraph 55.
No cold water.	Refer to paragraph 56.

▲ WARNING

To reduce the risk of electric shock, fire, explosion, serious injury or death:

- **Disconnect electric power to the washer before servicing.**
- **Never start the washer with any guards/panels removed.**
- **Whenever ground wires are removed during servicing, these ground wires must be reconnected to ensure that the washer is properly grounded.**

W003

58. WATER DOES NOT SHUT OFF

POSSIBLE CAUSE	TO CORRECT
Sediment in water mixing valve.	Disassemble and clean, <i>Figure 30</i> .
Weak or broken armature spring in water mixing valve.	Replace spring, <i>Figure 30</i> .
Inoperative pressure switch.	Test switch, paragraph 44, and replace if inoperative, paragraph 18.
Pressure switch improperly adjusted.	Adjust switch, paragraph 37.
Cut or worn pressure hose.	Replace pressure hose.
Clogged pressure hose.	Remove hose from outer tub and clean.
Incorrect wiring.	Refer to appropriate wiring diagram.

59. WATER DOES NOT DRAIN FROM CYLINDER

POSSIBLE CAUSE	TO CORRECT
Obstruction in drain valve.	Clean valve, <i>Figure 27</i> .
Kinked drain hose.	Straighten drain hose.
Pump Models: Obstruction in pump.	Clean pump, <i>Figure 38</i> .
Pump Models: Inoperative pump motor.	Test pump motor, paragraph 51, and replace if inoperative, paragraph 30.
Inoperative cycle timer.	Test timer, paragraph 47, and replace if inoperative, paragraph 20.
Incorrect wiring.	Refer to appropriate wiring diagram.

▲ WARNING

To reduce the risk of electric shock, fire, explosion, serious injury or death:

- **Disconnect electric power to the washer before servicing.**
- **Never start the washer with any guards/panels removed.**
- **Whenever ground wires are removed during servicing, these ground wires must be reconnected to ensure that the washer is properly grounded.**

W003

60. DRIVE MOTOR DOES NOT RUN

POSSIBLE CAUSE	TO CORRECT
No electrical power.	Check fuses, switch box and power cord.
Inoperative cycle timer.	Test timer, paragraph 47, and replace if inoperative, paragraph 20.
Inoperative reversing timer.	Test timer, paragraph 48, and replace if inoperative, paragraph 20.
Inoperative action switch.	Test switch, paragraph 42, and replace if inoperative.
Improperly adjusted door lock switch.	Adjust switch, paragraph 38.
Inoperative door lock switch.	Test switch, paragraph 43, and replace if inoperative, paragraph 13.
Motor overload protector has cycled.	Wait two or three minutes for overload protector to reset. If protector cycles repeatedly, refer to paragraph 61.
Inoperative capacitor.	Test capacitor, paragraph 46, and replace if inoperative, paragraph 21.
Inoperative drive motor.	Test motor, paragraph 52, and replace if inoperative, paragraph 28.
Inoperative motor relay.	Test motor relay, paragraph 45, and replace if inoperative, paragraph 19.
Broken, loose or incorrect wiring.	Refer to appropriate wiring diagram.

61. MOTOR OVERLOAD PROTECTOR CYCLES REPEATEDLY

POSSIBLE CAUSE	TO CORRECT
Low voltage.	See Installation Instructions (supplied with washer) for electrical requirements.
Belt is too tight.	Adjust belt, paragraph 36.
Inoperative motor overload protector.	Replace drive motor, paragraph 28.
Water does not drain from clothes cylinder.	Refer to paragraph 59.
Inoperative motor relay.	Test motor relay, paragraph 45, and replace if inoperative, paragraph 19.

▲ WARNING

To reduce the risk of electric shock, fire, explosion, serious injury or death:

- **Disconnect electric power to the washer before servicing.**
- **Never start the washer with any guards/panels removed.**
- **Whenever ground wires are removed during servicing, these ground wires must be reconnected to ensure that the washer is properly grounded.**

W003

62. CYLINDER DOES NOT TURN

POSSIBLE CAUSE	TO CORRECT
Drive motor does not run.	Refer to paragraph 60.
Loose or broken drive belt.	Adjust belt, paragraph 36, or replace belt.

63. CYCLE TIMER DOES NOT ADVANCE

POSSIBLE CAUSE	TO CORRECT
Inoperative timer motor.	Test timer motor, paragraph 49, and replace if inoperative, paragraph 20.

TIMER CYCLE SEQUENCE					
OPERATIONS	MINUTES	GALLONS WATER	WATER TEMPERATURE WITH WASH TEMPERATURE SWITCH SET AT:		
			Hot	Warm	Cold
Wash Fill	1/2	1.9 (7.22 L)	Hot	Warm	Cold
Wash Fill and Tumble	6 - 1/2	* Variable	Hot	Warm	Cold
Tumble	1/2				
Tumble and Rinse Fill	3	* Variable	Cold	Cold	Cold
Tumble	1				
Spin	1				
Rinse Fill	1	3.8 (14.44 L)	† Cold	Cold	Cold
Tumble and Rinse Fill	1-1/2	* Variable	† Cold	Cold	Cold
Tumble	1				
Spin	1-1/2				
Rinse Fill	1	3.8 (14.44 L)	† Cold	Cold	Cold
Tumble and Rinse Fill	1-1/2	* Variable	† Cold	Cold	Cold
Tumble	1				
Spin	7				
Pause	1-1/2				
Tumble	1/2				
TOTALS	30	**VARIABLE			

* If proper water level is reached before end of fill period, pressure switch will stop water fill.

** Amount of water used depends on size of load and fabrics being washed. Approximately 43 gallons (163.4 L) for 25 lb. (11.34 kg) AHAM cotton load.

† To obtain different rinse water temperatures in the WASH TEMPERATURE setting, refer to Section VI in this manual.

INDICATOR LIGHTS:

ON light is lit throughout the entire wash cycle.

DETERGENT light comes on approximately 30 seconds after start of cycle and remains lit for 1-1/2 minutes.

BLEACH light comes on approximately 4 minutes after start of cycle and remains lit for 1-1/2 minutes.

SOFTENER light comes on approximately 18 minutes after start of cycle and remains lit for 1-1/2 minutes.

SECTION V

Rinse Water Options

▲ WARNING

To reduce the risk of electric shock, fire, explosion, serious injury or death:

- Disconnect electric power to the washer before servicing.
- Never start the washer with any guards/panels removed.
- Whenever ground wires are removed during servicing, these ground wires must be reconnected to ensure that the washer is properly grounded.

W003

The cycle timer on the Superload II Washer-Extractor is wired for all cold water rinses, *Figure 61*. For other rinse water options, see Page 66 or 67.

Wash Temperature (Switch Setting)	Rinse Water Temperature
Hot	Cold
Warm	Cold
Cold	Cold

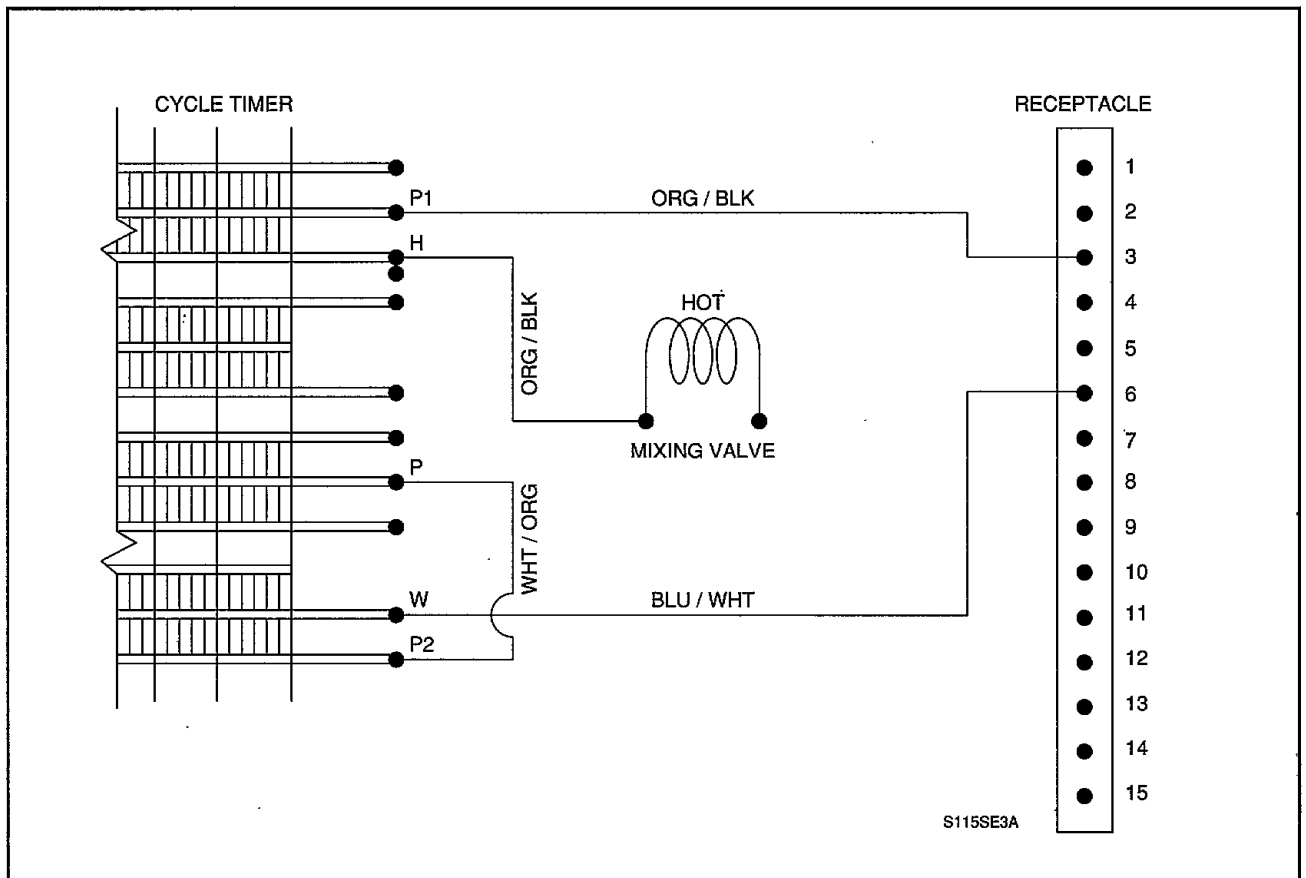

Figure 61

▲ WARNING

To reduce the risk of electric shock, fire, explosion, serious injury or death:

- Disconnect electric power to the washer before servicing.
- Never start the washer with any guards/panels removed.
- Whenever ground wires are removed during servicing, these ground wires must be reconnected to ensure that the washer is properly grounded.

W003

To obtain warm water rinse on the "WARM" WASH TEMPERATURE (switch setting), rewire the cycle timer as shown in Figure 62.

1. Remove each of the orange/black wires from the cycle timer terminals "P1" and "H", then connect the ends of these wires together using a connector, Part No. 21091.
2. Remove the white/orange wire from the cycle timer terminal "P2" and reconnect the wire to timer terminal "P1".

Wash Temperature (Switch Setting)	Rinse Water Temperature
Hot	Cold
Warm	Warm
Cold	Cold

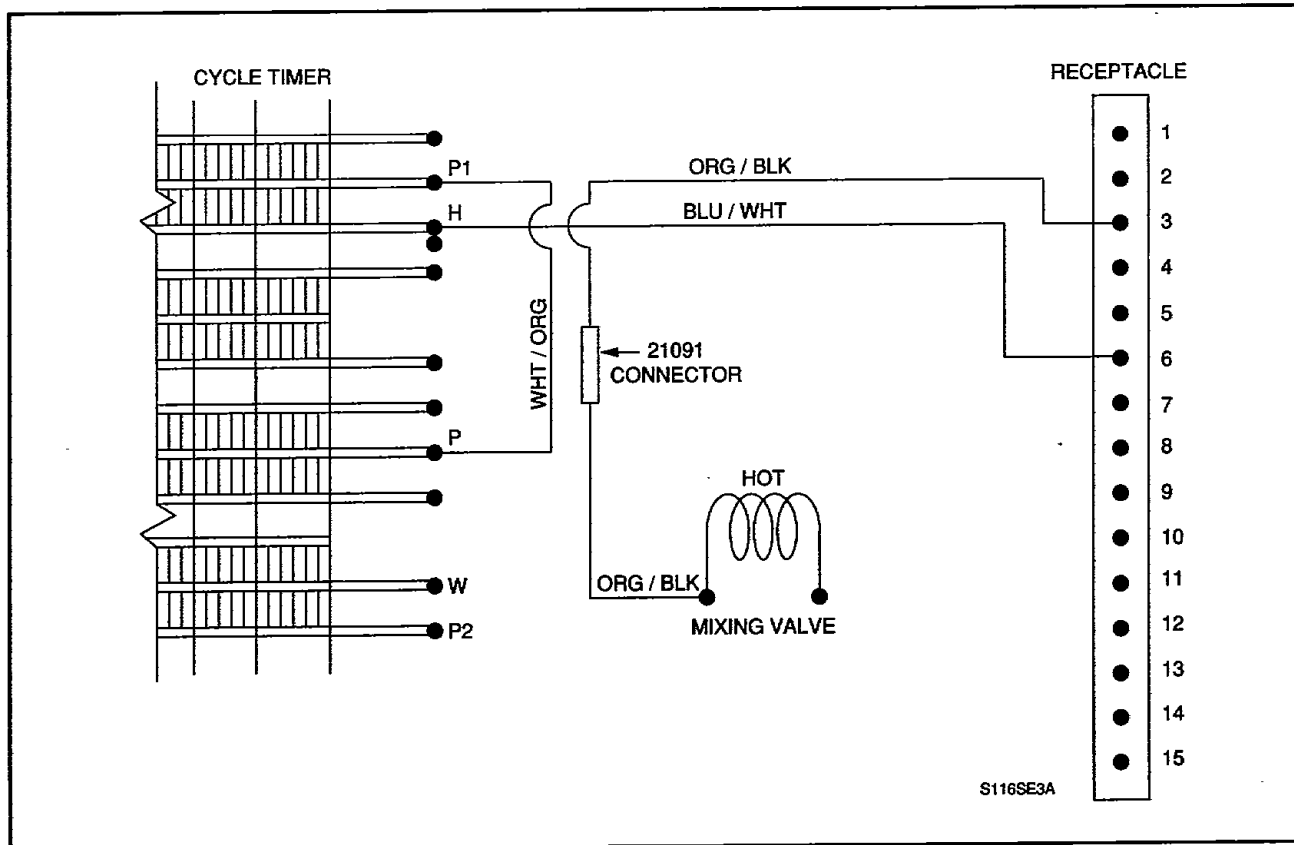

Figure 62

▲ WARNING

To reduce the risk of electric shock, fire, explosion, serious injury or death:

- Disconnect electric power to the washer before servicing.
- Never start the washer with any guards/panels removed.
- Whenever ground wires are removed during servicing, these ground wires must be reconnected to ensure that the washer is properly grounded.

W003

To obtain warm water rinses on the "HOT" or "WARM" WASH TEMPERATURE (switch setting), rewire the cycle timer as shown in *Figure 63*.

1. Remove each of the orange/black wires from the cycle timer terminals "P1" and "H", then connect the ends of these wires together using a connector, Part No. 21091.
2. Remove the white/orange wire from the cycle timer terminal "P2" and reconnect the wire to timer terminal "P1".
3. Remove the blue/white wire from the cycle timer terminal "W" and reconnect the wire to timer terminal "H".
4. Add a jumper wire between cycle timer terminals "H" and "R".

Wash Temperature (Switch Setting)	Rinse Water Temperature
Hot	Warm
Warm	Warm
Cold	Cold

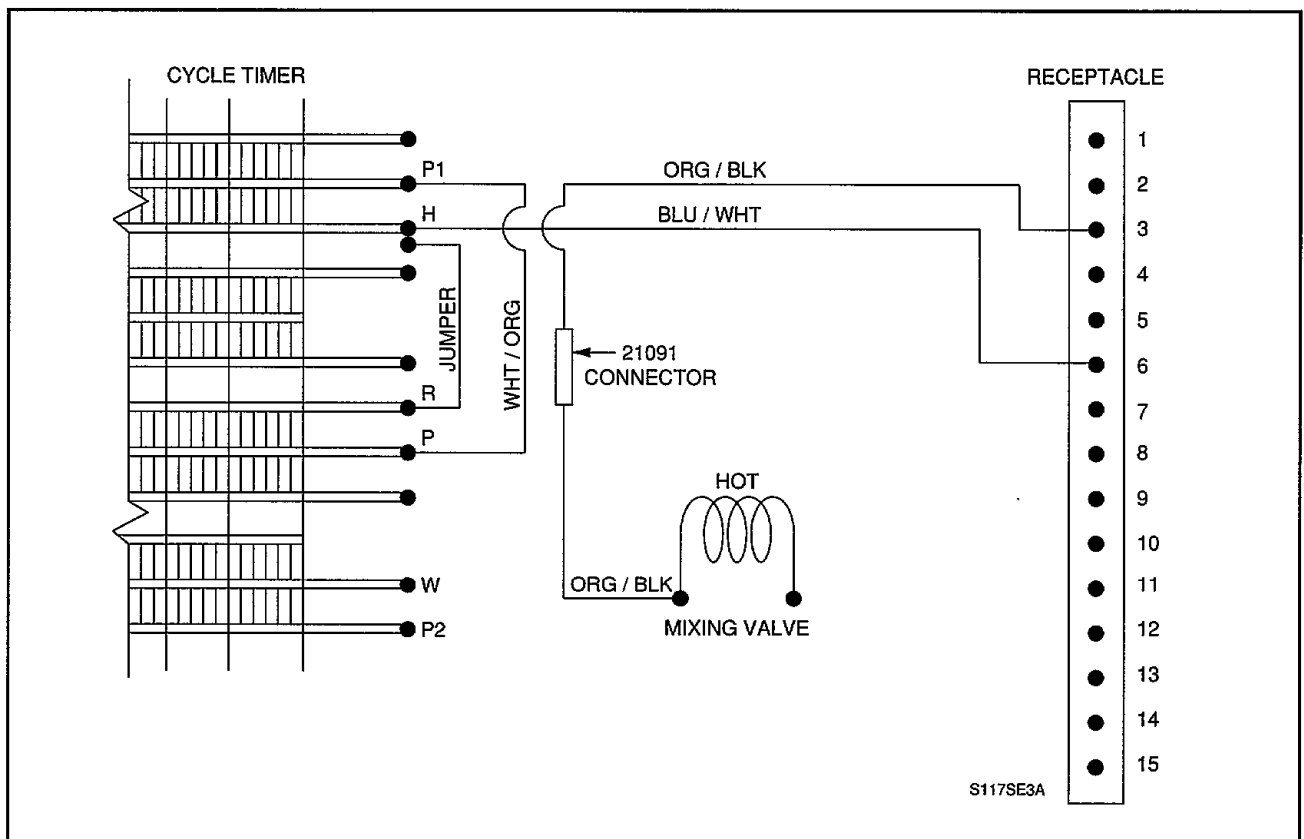
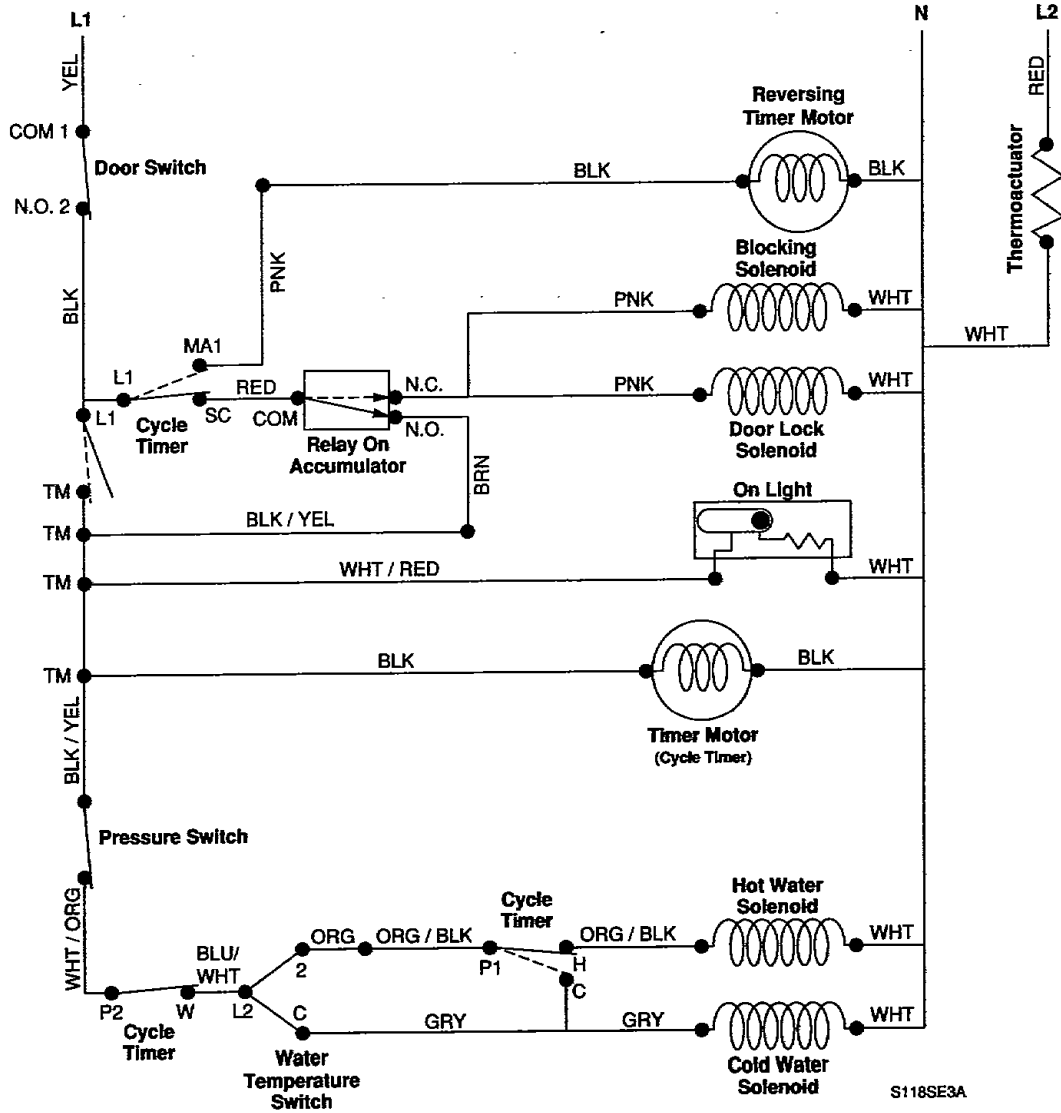

Figure 63

SECTION VI

Wiring Schematics



START AND FILL CIRCUIT

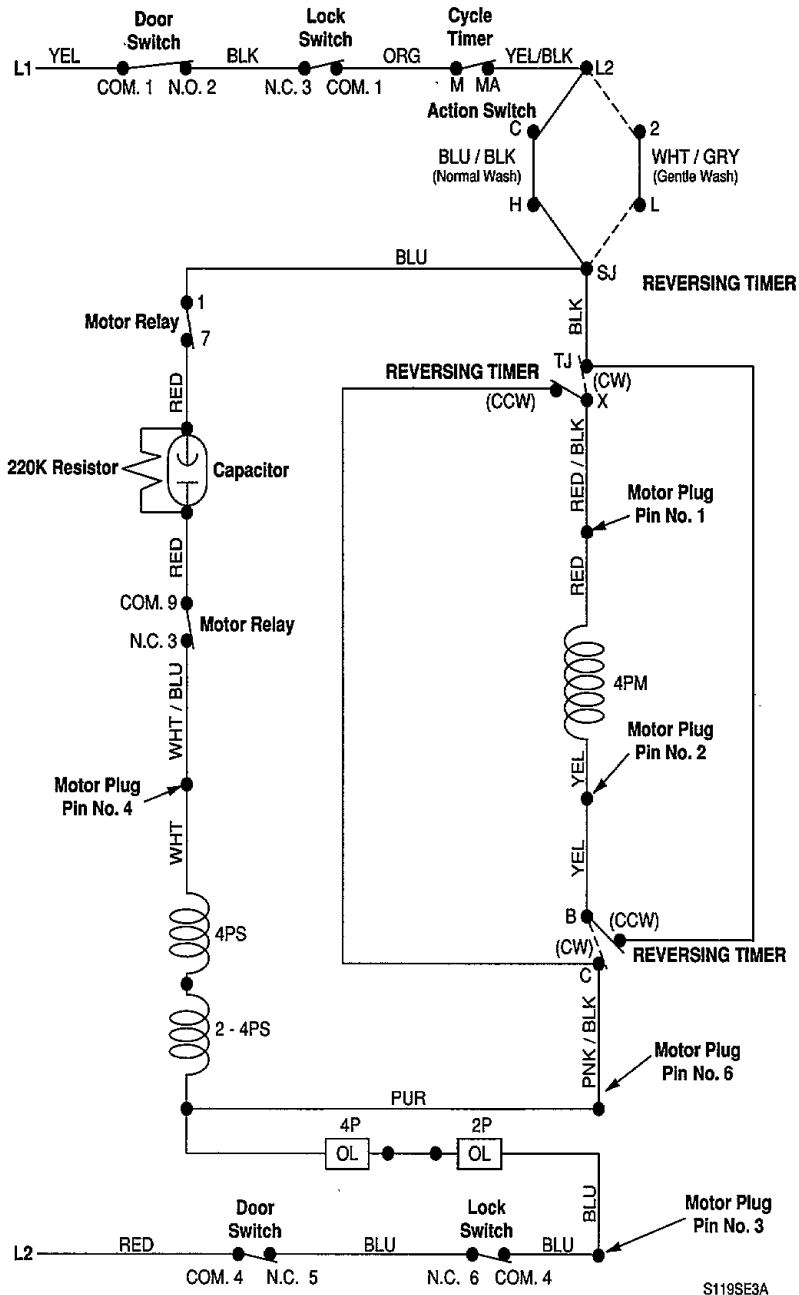

**WASH CIRCUIT
(Normal or Gentle)**

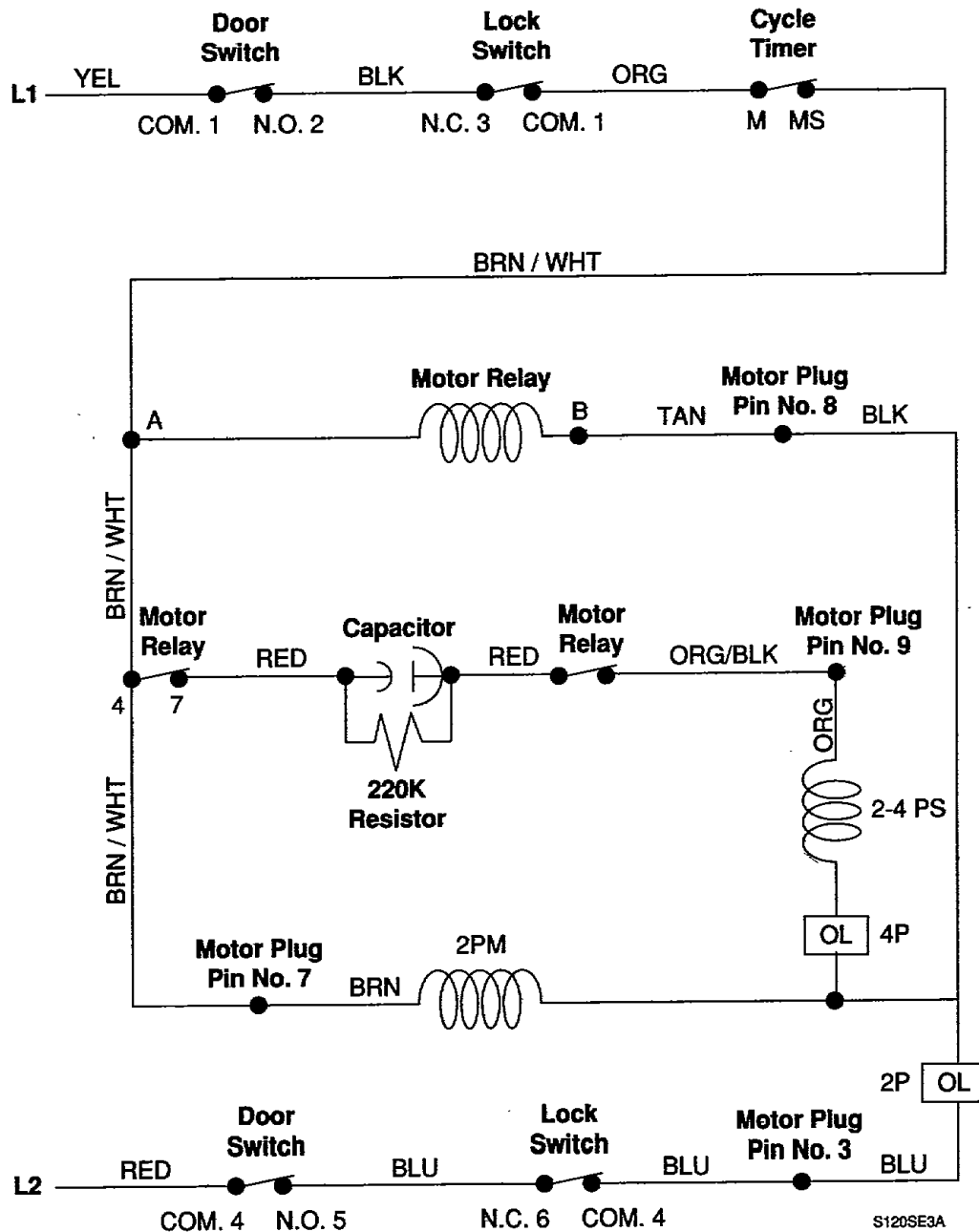

SPIN CIRCUIT

SECTION VII

Wiring Diagram

TIMER CHARTS

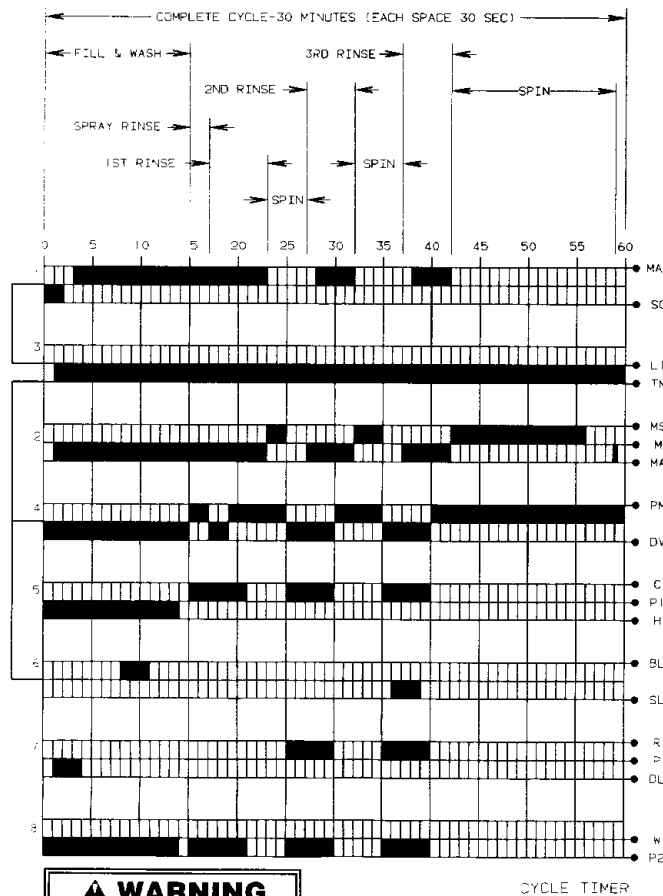
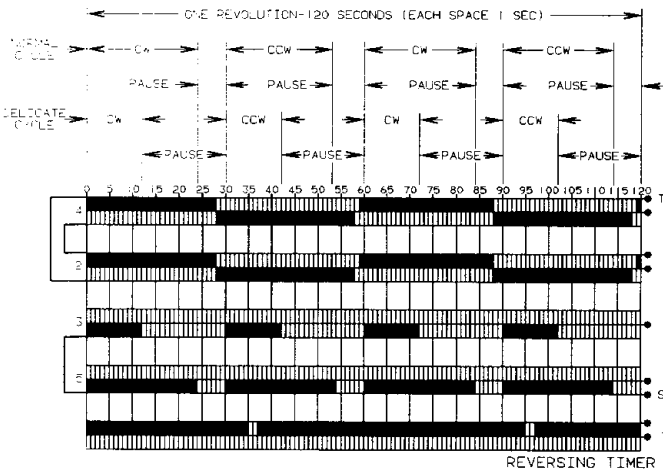

WARNING
 To avoid serious damage to motor-drive and timers DO NOT advance either timer with power to machine or with the wash cylinder moving.

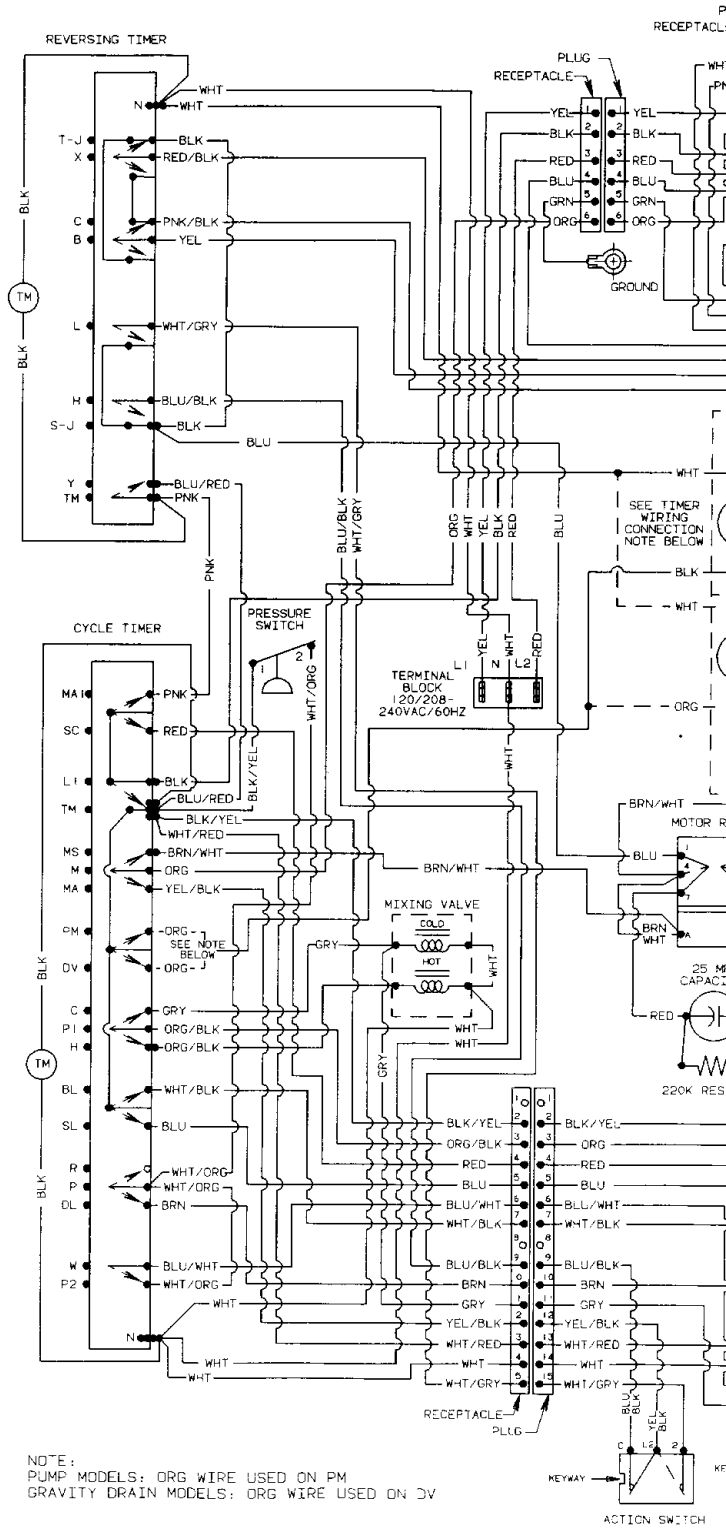

NOTE:
 PUMP MODELS: ORG WIRE USED ON PM
 GRAVITY DRAIN MODELS: ORG WIRE USED ON DV

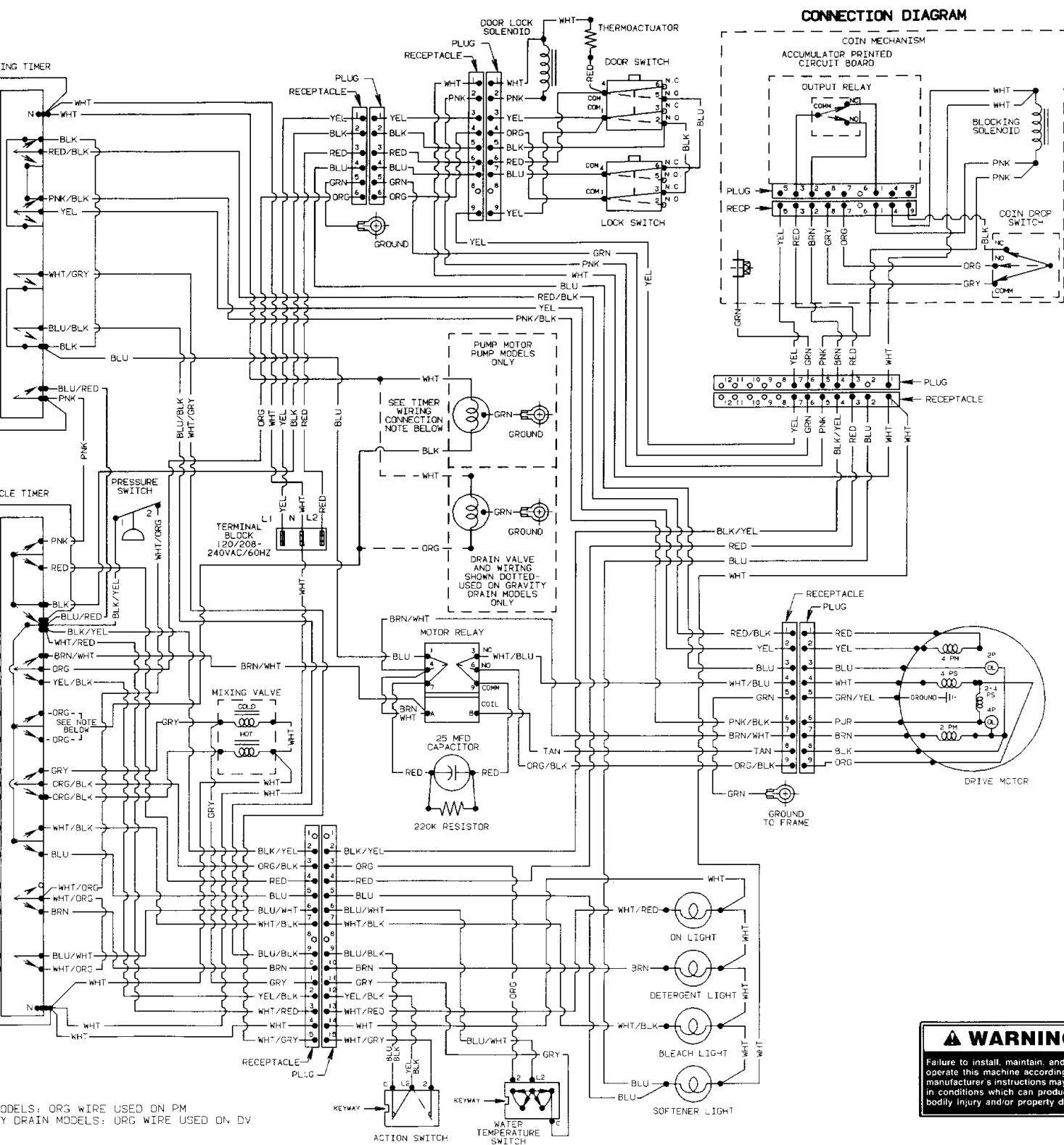

CONNECTION DIAGRAM

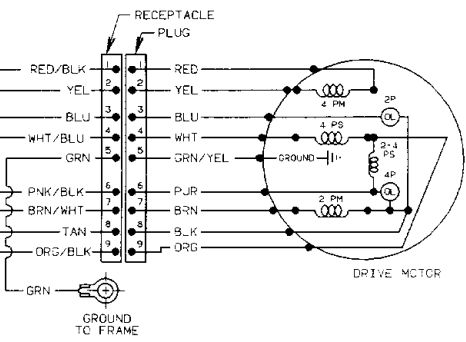
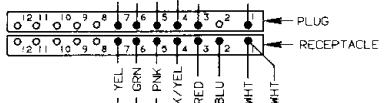
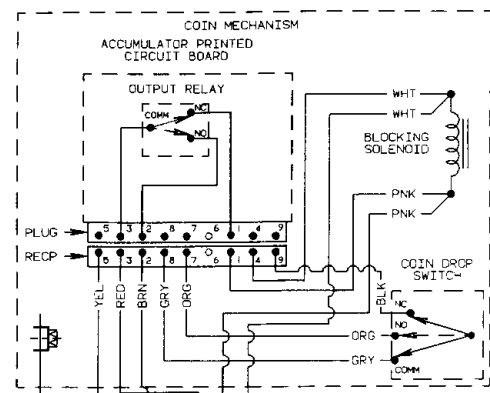

WARNING
 Failure to install, maintain and/or operate this machine according to manufacturer's instructions may result in conditions which can produce bodily injury and/or property damage.

MODELS: ORG WIRE USED ON PM
 Y DRAIN MODELS: ORG WIRE USED ON DV

TIMER CHARTS

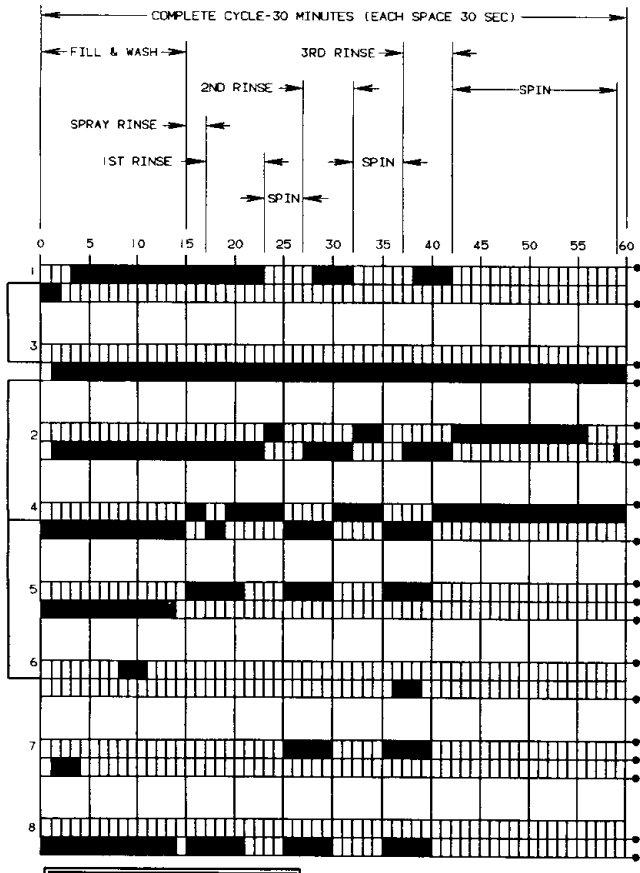
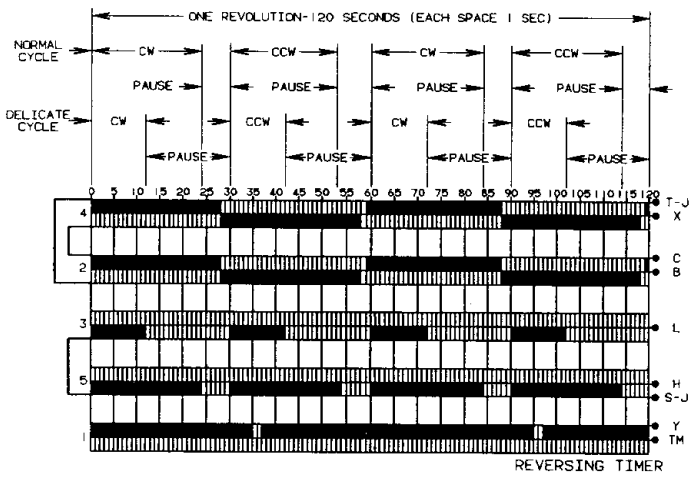

WARNING

To avoid serious damage to motor-drive and timers DO NOT advance either timer with power to machine or with the wash cylinder moving.

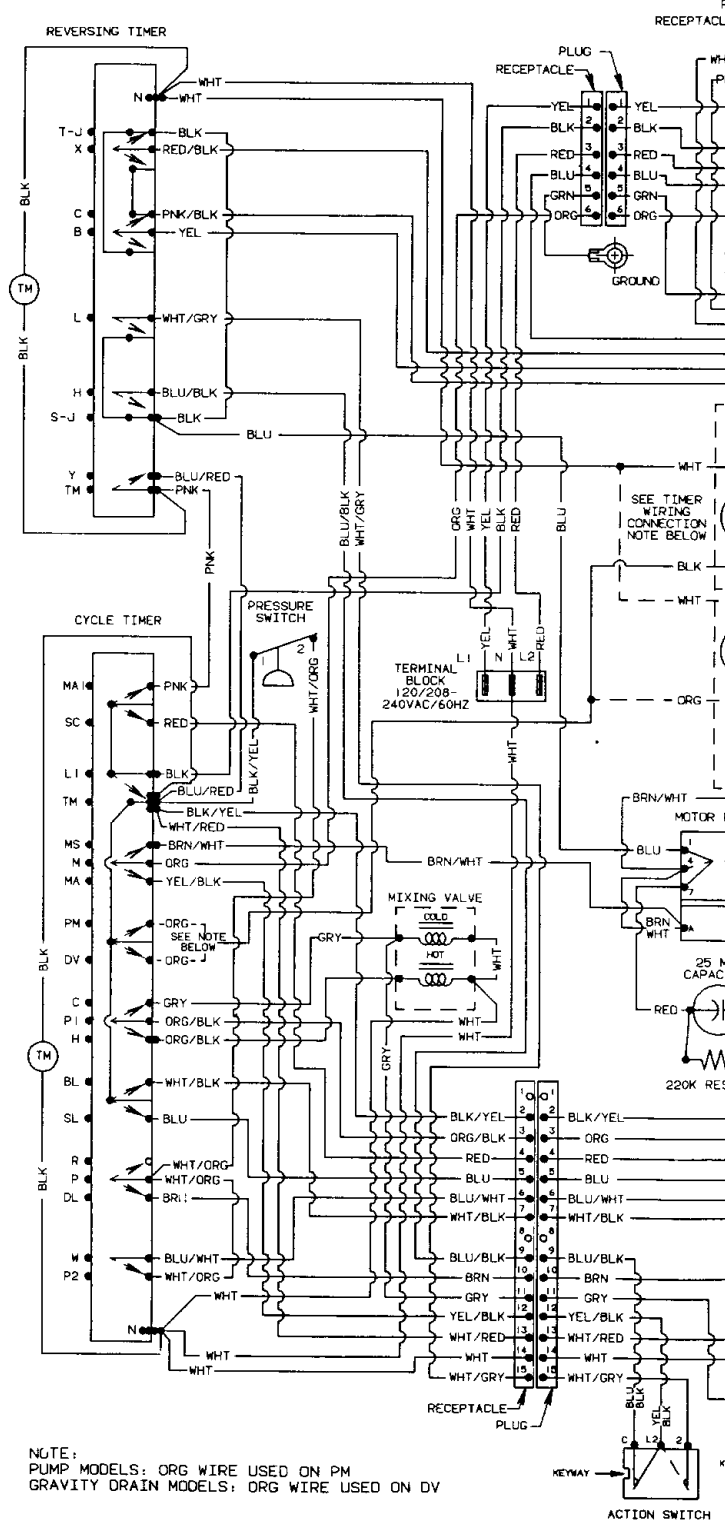

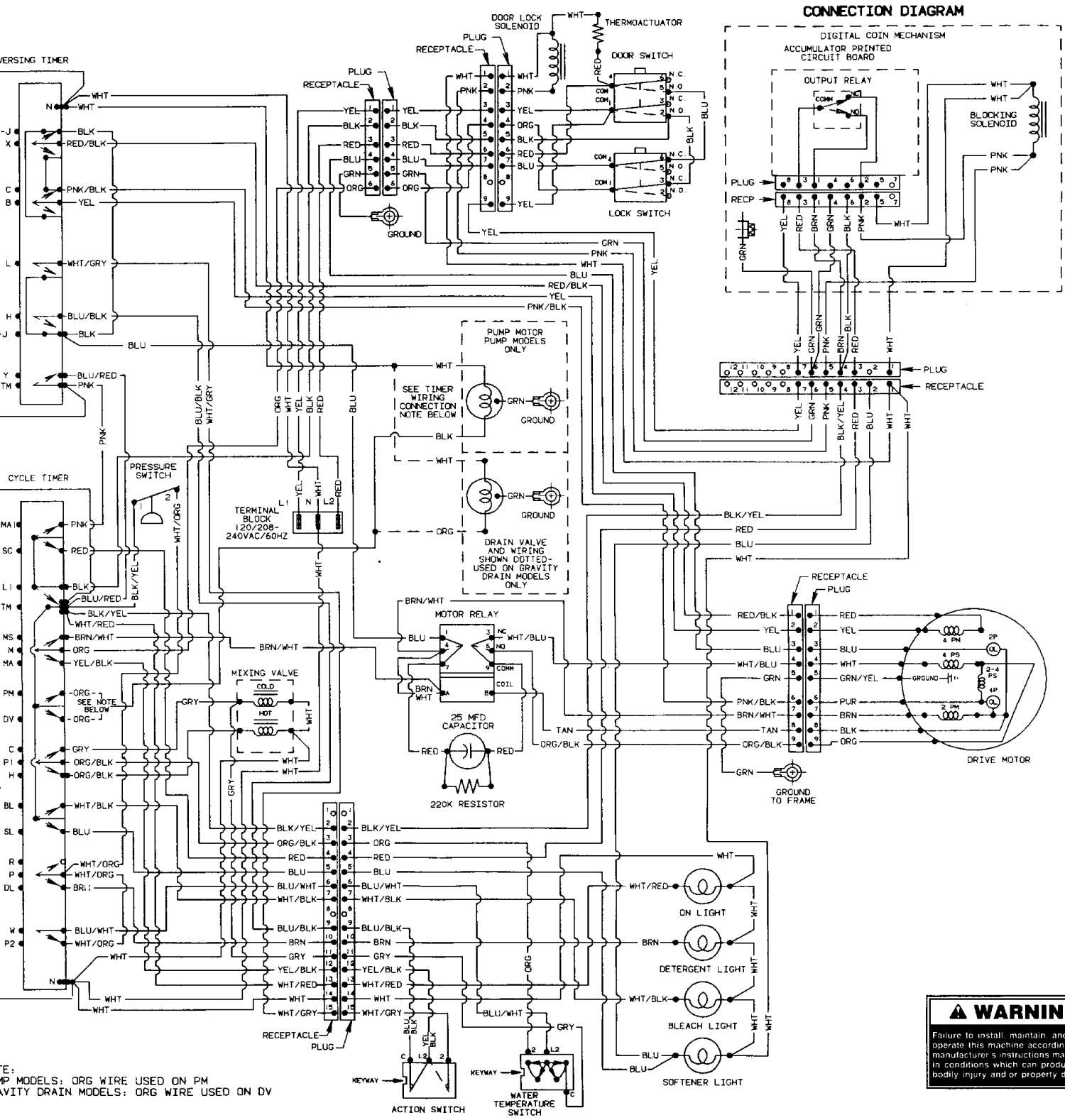

CONNECTION DIAGRAM

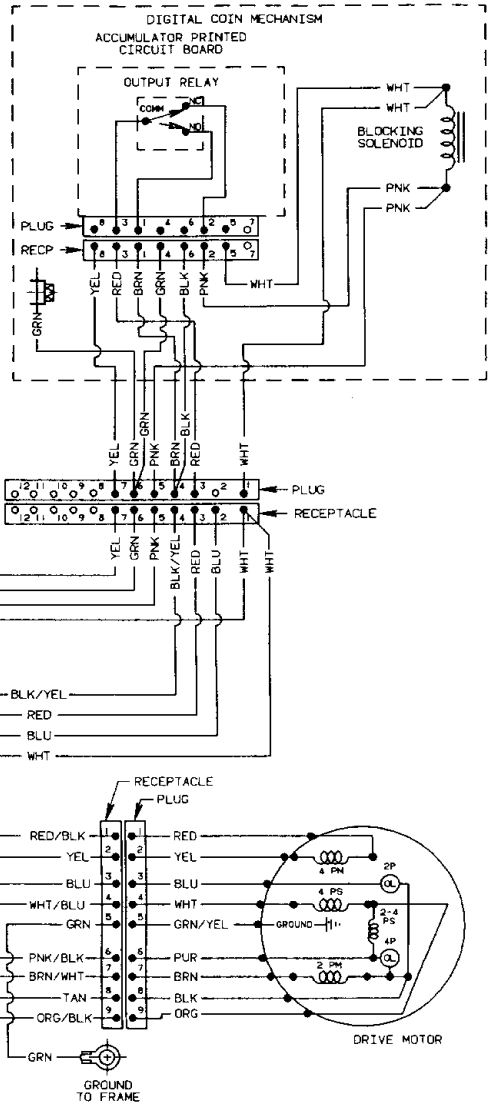

NOTE: GRAVITY DRAIN MODELS: ORG WIRE USED ON PM AND DV MODELS; ORG WIRE USED ON PM AND GRAVITY DRAIN MODELS.

WARNING
 Failure to install, maintain, and/or operate this machine according to manufacturer's instructions may result in conditions which can produce bodily injury and/or property damage.

TIMER CHARTS

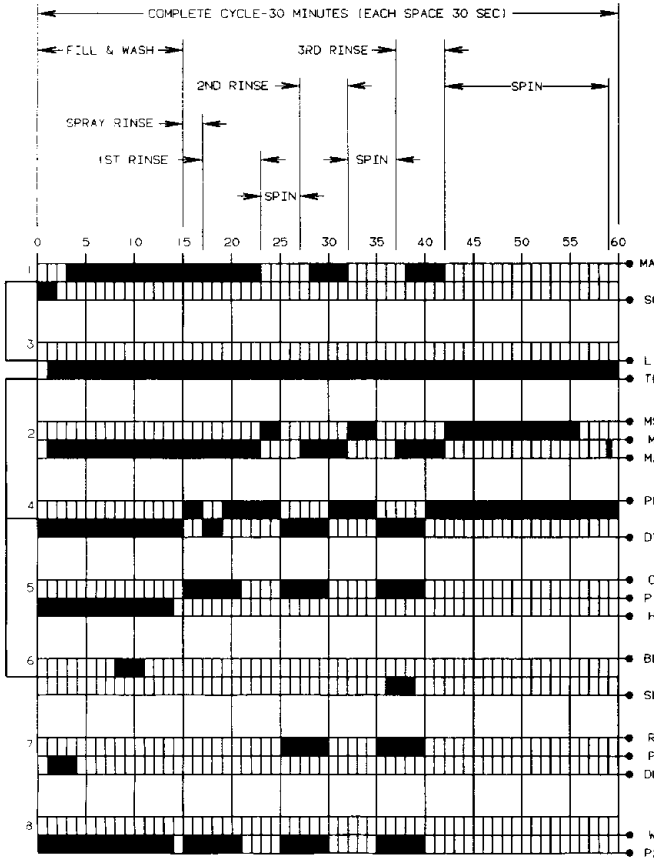
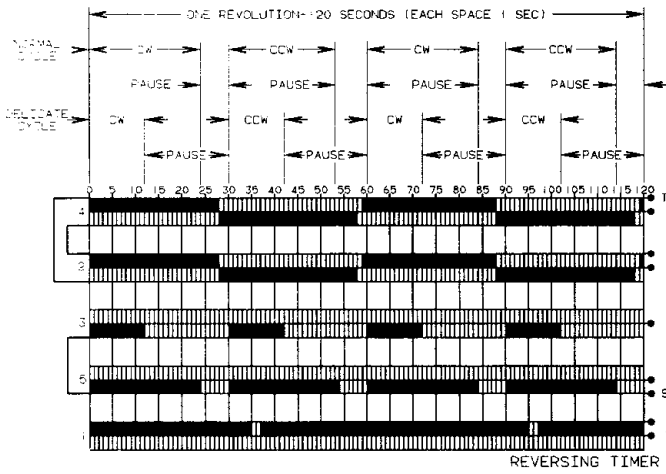

WARNING

To avoid serious damage to motor-drive and timers DO NOT advance either timer with power to machine or with the wash cylinder moving.

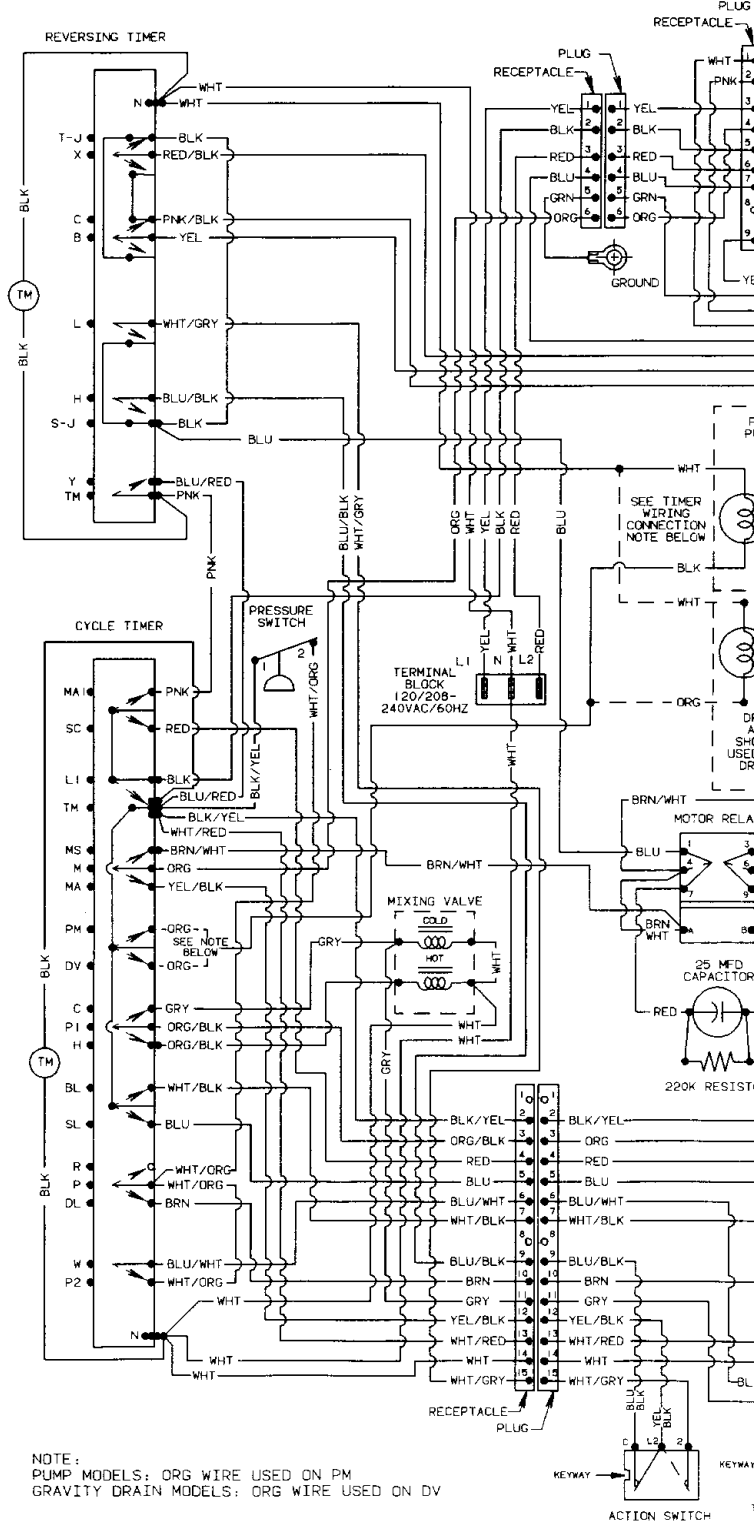

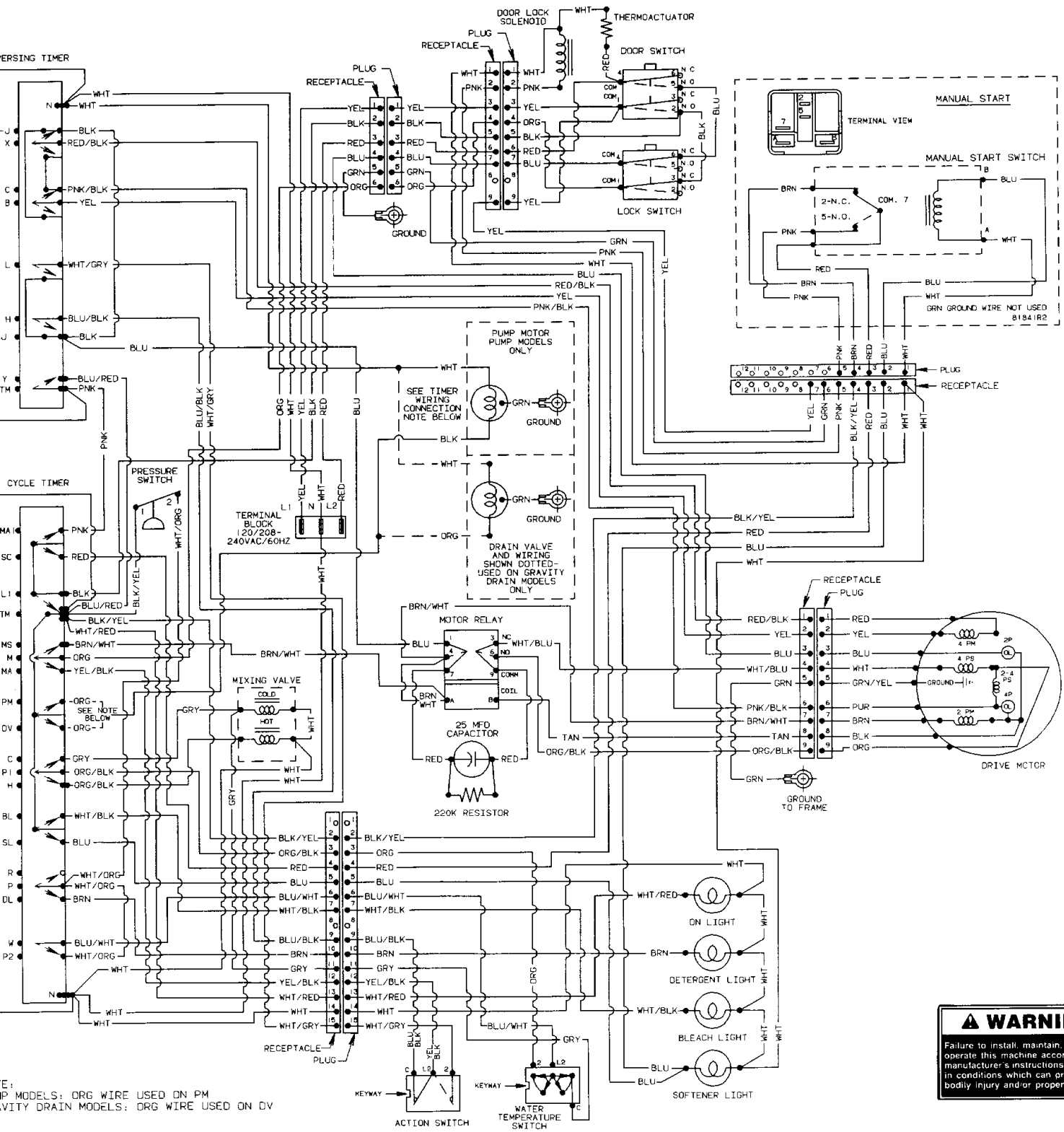

E:
 P MODELS: ORG WIRE USED ON PM
 VITY DRAIN MODELS: ORG WIRE USED ON DV

⚠ WARNING
 Failure to install, maintain, and/or operate this machine according to manufacturer's instructions may result in conditions which can produce bodily injury and/or property damage.

TIMER CHARTS

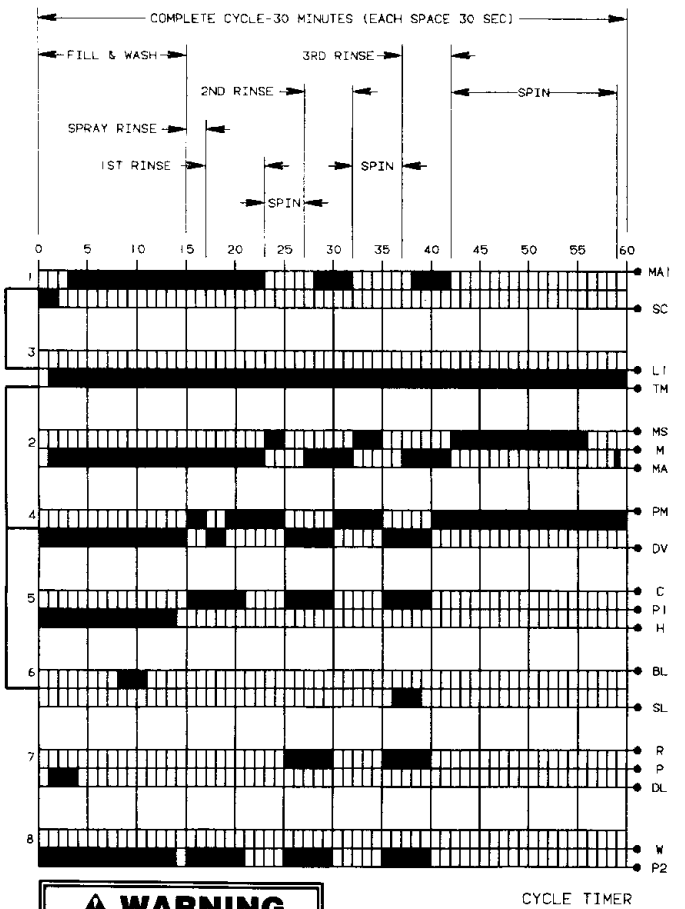
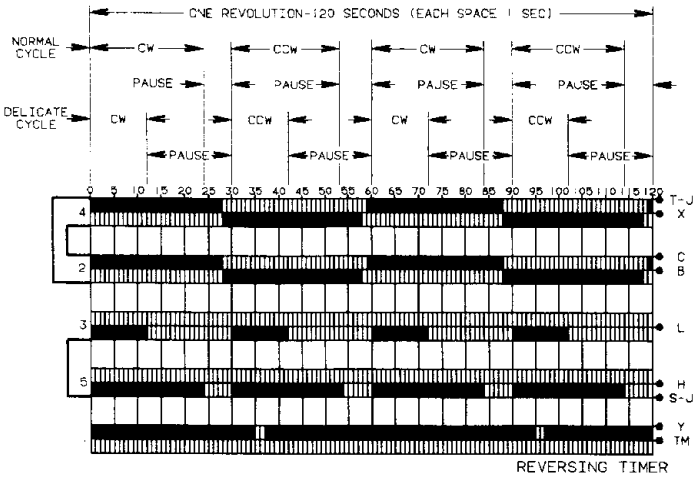

WARNING
 To avoid serious damage to motor-drive and timers DO NOT advance either timer with power to machine or with the wash cylinder moving.

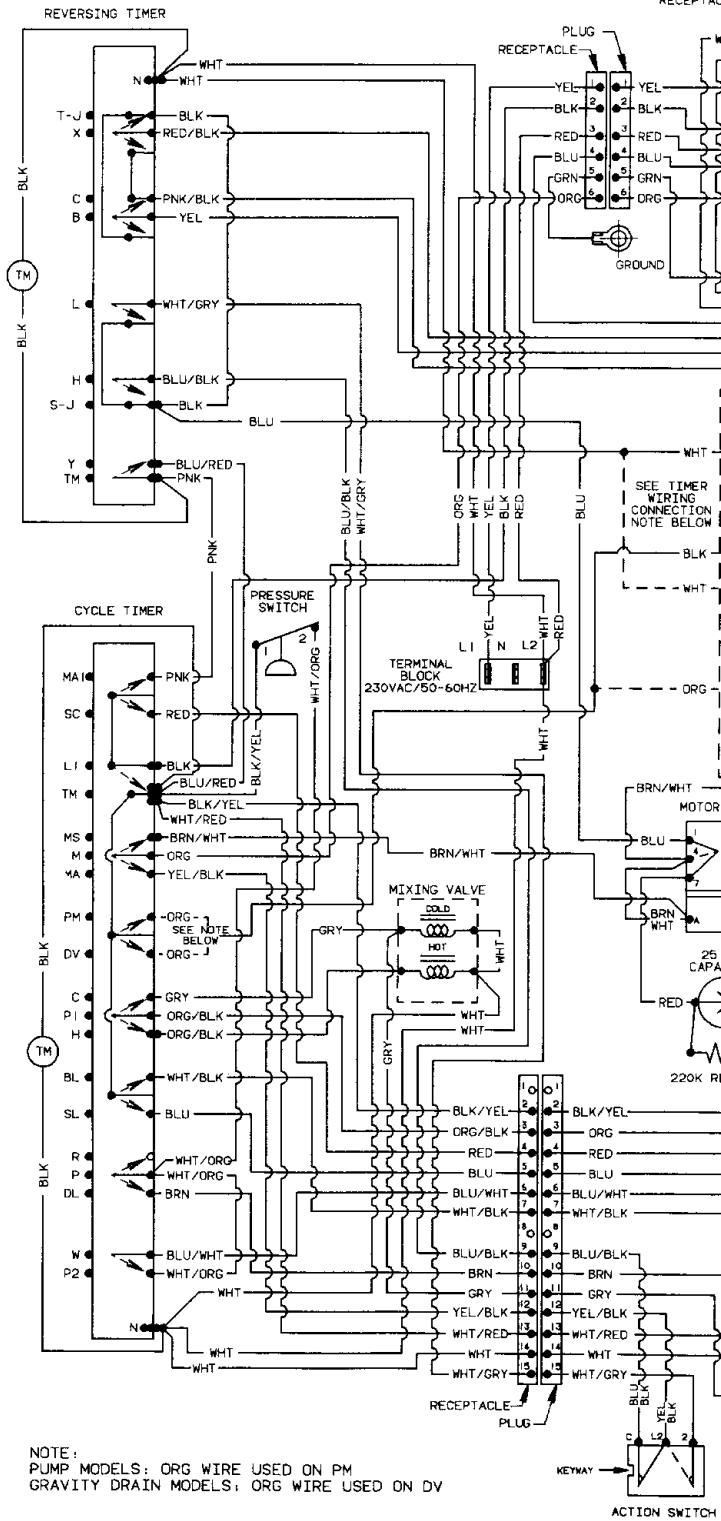

**METERED MODELS — 50 HERTZ
 (Non-Digital Coin Drop)**

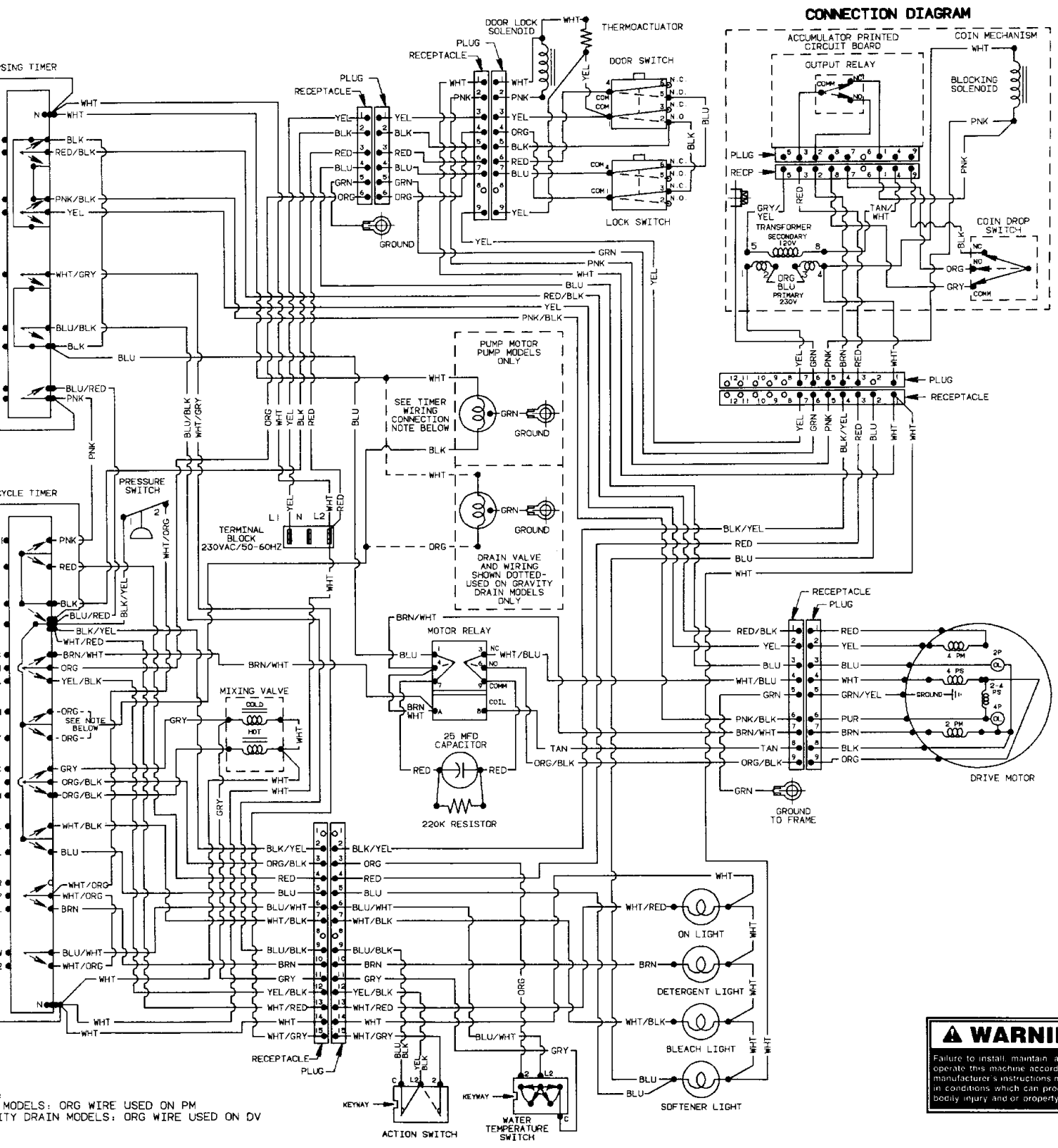

CONNECTION DIAGRAM

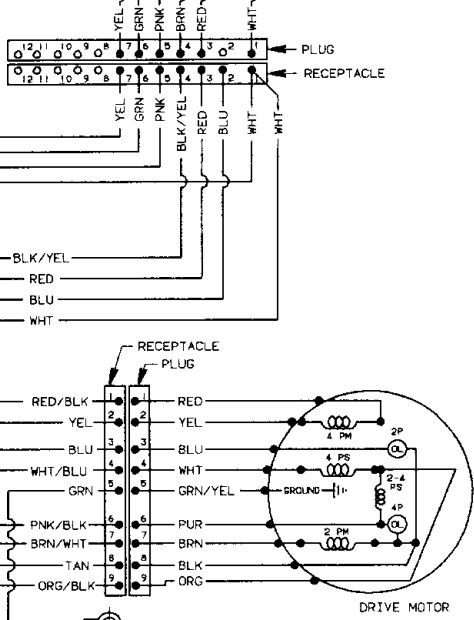
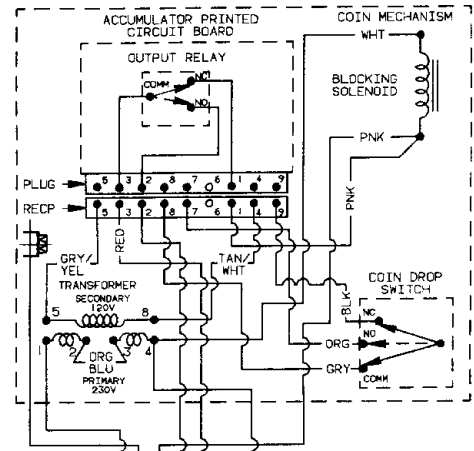

MODELS: ORG WIRE USED ON PM
 GRAVITY DRAIN MODELS: ORG WIRE USED ON DV

WARNING
 Failure to install, maintain and/or operate this machine according to manufacturer's instructions may result in conditions which can produce bodily injury and/or property damage.

TIMER CHARTS

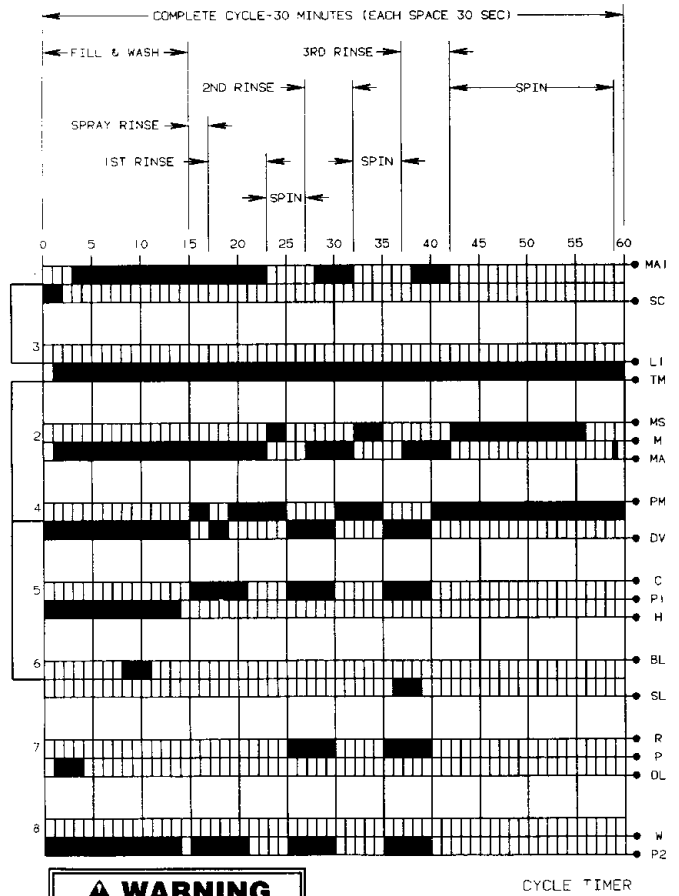
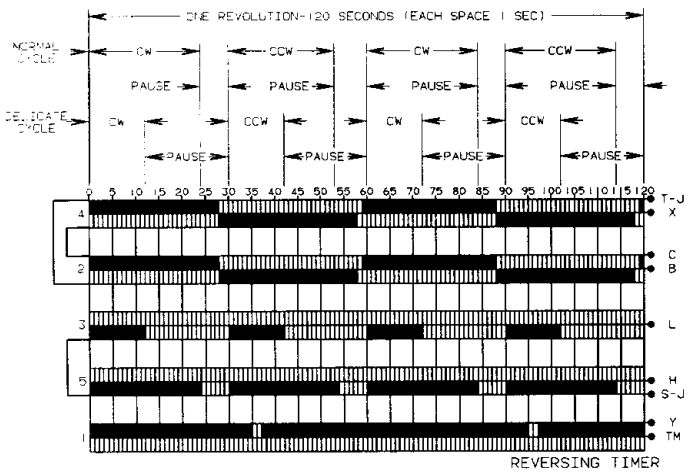

⚠ WARNING
 To avoid serious damage to motor-drive and timers DO NOT advance either timer with power to machine or with the wash cylinder moving.

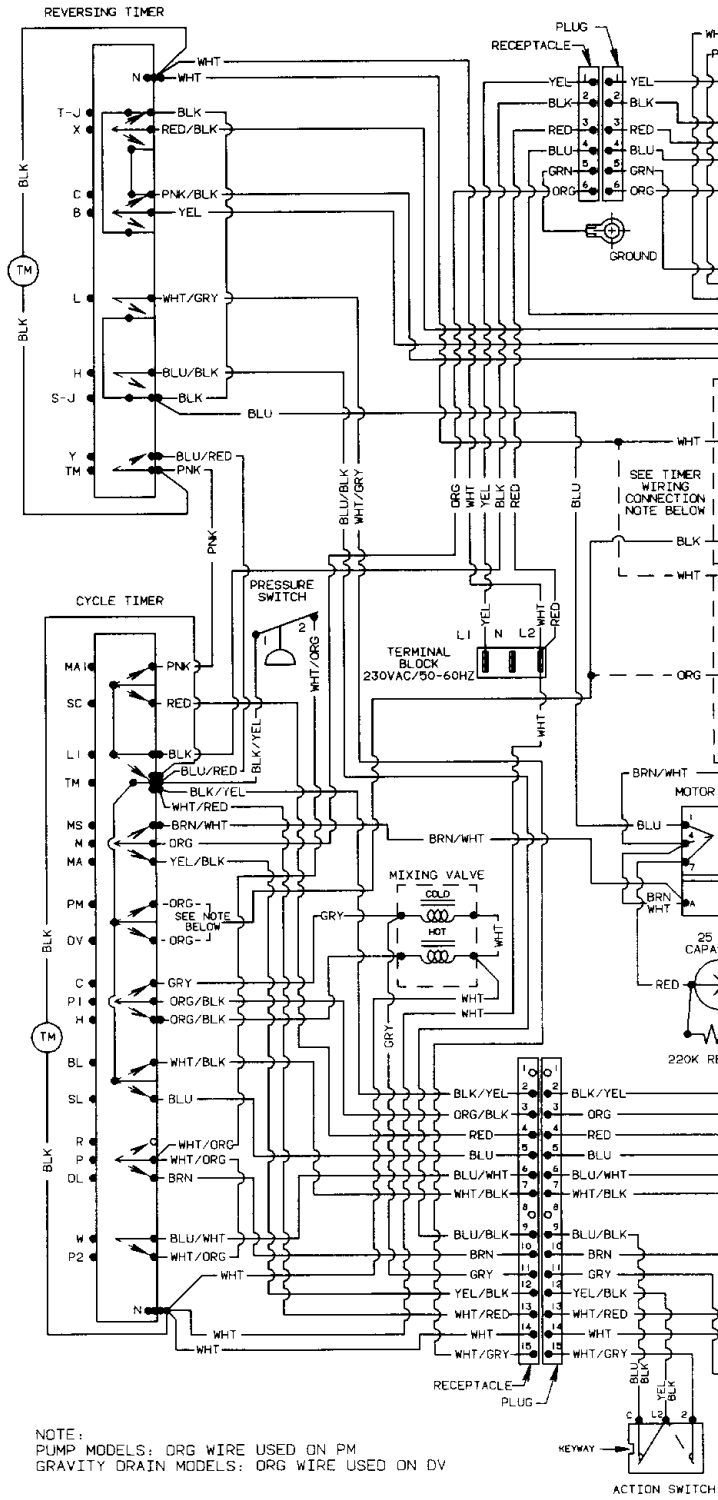

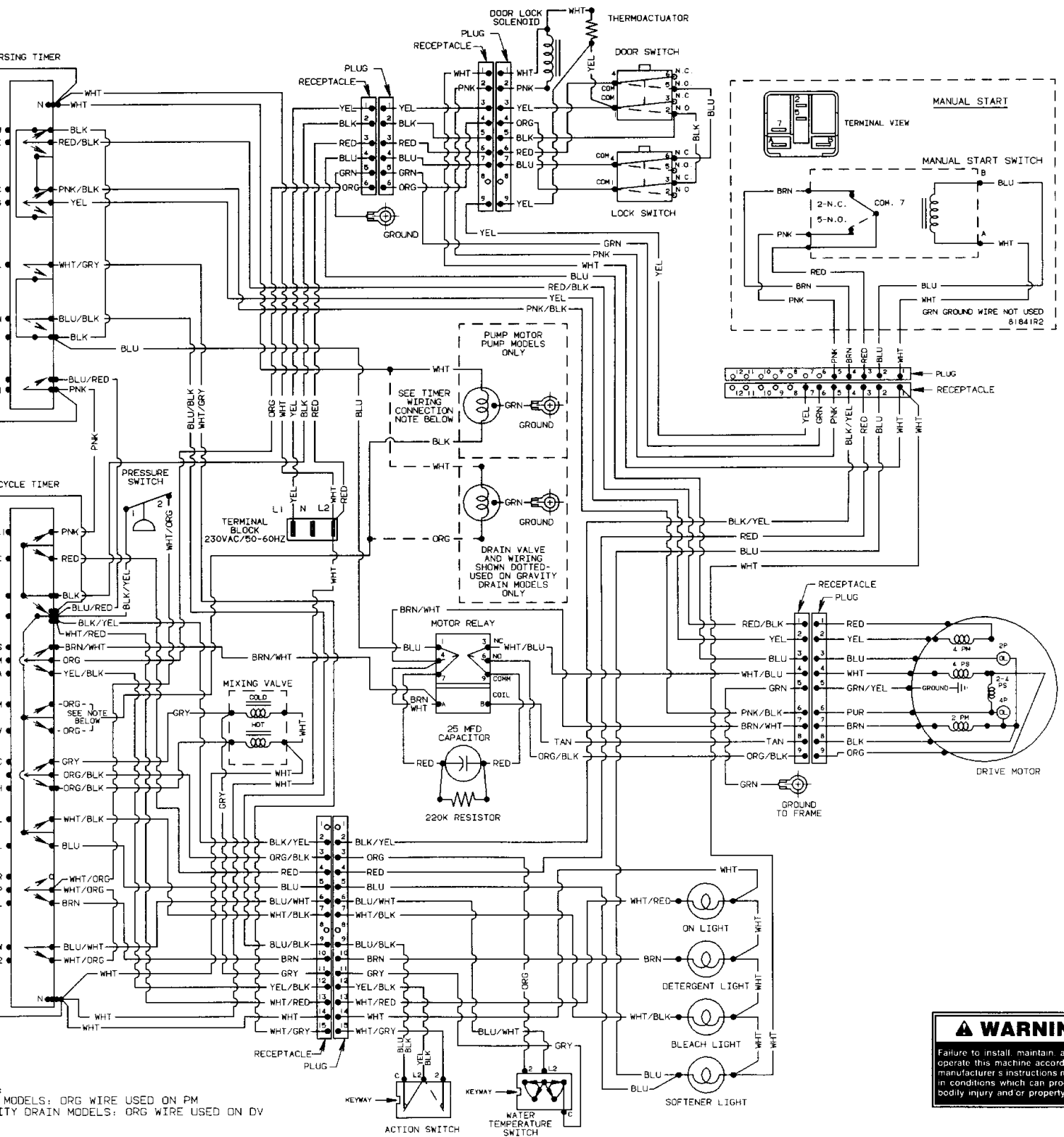

MODELS: ORG WIRE USED ON PM
 GRAVITY DRAIN MODELS: ORG WIRE USED ON DV

⚠ WARNING
 Failure to install, maintain and/or
 operate this machine according to
 manufacturer's instructions may result
 in conditions which can produce
 bodily injury and/or property damage.