



AD-120 Service Manual Phase 4

American Dryer Corporation
88 Currant Road
Fall River MA 02720-4781
Telephone: (508) 678-9010 / Fax: (508) 678-9447
e-mail address: service@amdry.com

Retain This Manual In A Safe Place For Future Reference

American Dryer Corporation products embody advanced concepts in engineering, design, and safety. If this product is properly maintained, it will provide many years of safe, efficient, and trouble-free operation.

ONLY properly licensed technicians should service this equipment.

OBSERVE ALL SAFETY PRECAUTIONS displayed on the equipment or specified in the installation/operator's manual included with the dryer.

WARNING: UNDER NO CIRCUMSTANCES should the door switch or the heat circuit devices ever be disabled.

WARNING: The dryer must never be operated with any of the back guards, outer tops, or service panels removed. PERSONAL INJURY or FIRE COULD RESULT.

We have tried to make this manual as complete as possible and hope you will find it useful. ADC reserves the right to make changes from time to time, without notice or obligation, in prices, specifications, colors, and material, and to change or discontinue models.

Important

For your convenience, log the following information:

DATE OF PURCHASE _____ MODEL NO. AD-120
DISTRIBUTORS NAME _____
Serial Number(s) _____

Replacement parts can be obtained from your distributor or the ADC factory. When ordering replacement parts from the factory, you can FAX your order to ADC at (508) 678-9447 or telephone your orders directly to the ADC Parts Department at (508) 678-9010. Please specify the dryer **model number** and **serial number** in addition to the **description** and **part number**, so that your order is processed accurately and promptly.

The illustrations on the following pages may not depict your particular dryer exactly. The illustrations are a composite of the various dryer models. Be sure to check the descriptions of the parts thoroughly before ordering.

INSTRUCTIONS TO BE FOLLOWED IN THE EVENT THE USER SMELLS GAS MUST BE POSTED IN A PROMINENT LOCATION. THE INSTRUCTIONS TO BE POSTED SHALL BE OBTAINED FROM THE LOCAL GAS SUPPLIER.

IMPORTANT

YOU MUST DISCONNECT and LOCKOUT THE ELECTRIC SUPPLY and THE GAS SUPPLY or THE STEAM SUPPLY BEFORE ANY COVERS or GUARDS ARE REMOVED FROM THE MACHINE TO ALLOW ACCESS FOR CLEANING, ADJUSTING, INSTALLATION, or TESTING OF ANY EQUIPMENT per OSHA (Occupational Safety and Health Administration) STANDARDS.

FOR YOUR SAFETY

DO NOT STORE OR USE GASOLINE OR OTHER FLAMMABLE VAPOR AND LIQUIDS IN THE VICINITY OF THIS OR ANY OTHER APPLIANCE.

DO NOT DRY MOP HEADS IN THE DRYER.

DO NOT USE DRYER IN THE PRESENCE OF DRY CLEANING FUMES.

WARNING

CHILDREN SHOULD NOT BE ALLOWED TO PLAY ON OR IN THE DRYER(S).

CHILDREN SHOULD BE SUPERVISED IF NEAR DRYER(S) IN OPERATION.

CAUTION

DRYER(S) SHOULD NEVER BE LEFT UNATTENDED WHILE IN OPERATION.

IMPORTANT

PLEASE OBSERVE ALL SAFETY PRECAUTIONS displayed on the equipment and/or specified in the installation/operator's manual included with the dryer.

Dryer(s) must not be installed or stored in an area where it will be exposed to water and/or weather.

The wiring diagram for the dryer is located in the front electrical control box area.

Table of Contents

Section I	Important Information	1
	A. Safety Precautions	1
Section II	Maintenance	3
	A. Cleaning	3
	B. Adjustments	4
	C. Lubrication	4
Section III	Installation Requirements	5
	A. Enclosure, Air Supply, and Exhaust Requirements	5
	B. Electrical and Gas Requirements	6
	C. Operation Service Check Procedure	6
Section IV	Description of Parts	8
	A. Control Box	8
	B. DSI Module	8
	C. Gas Burner Assembly	9
	D. Drive Motor	9
	E. Blower Motor and Impeller	9
	F. Idler Assembly	10
	G. Tumbler (Basket) Bearing and Pulley Arrangement	10
	H. Tumbler (Basket)	10
	I. Main Door Switch	11
	J. Sail Switch	11
	K. Hi-Limit	11
	L. Automatic Reset Thermostat	12
	M. Lint Drawer	12
	N. Lint Drawer Switch	12
Section V	Servicing	13
	A. Computer Controls	14
	B. Ignition Controls	17
	C. Thermostats	21
	D. Sail Switch Assembly	23
	E. Front Panel and Main Door Assemblies	24
	F. Pulleys	26
	G. Tumbler (Basket) Assembly	28
	H. Bearings	31

I. V-Belts	33
J. Motors	34
K. Impellor	35
Section VI Trouble shooting	37
Section VII Trouble shooting (Electrical)	42
A. Dryer Will Not Start	42
B. Drive Motor Does Not Run, Forward Mode. Blower Motor Runs	46
C. Drive Motor Does Not Run, Reverse Mode. Blower Motor Runs	47
D. Blower Motor Does Not Run. Drive Motor Does Not Run	49
E. Temperature Sensor Circuit	51
F. Heat Circuit (No Heat)	51
G. Ignitor Sparks, But No Ignition	54
Section VIII Technical Information	55
A. Motor Plate (High and Low Voltage)	55
B. Data Label	56
C. Using A Manometer	57
D. L.E.D. Display/Codes	58
E. Computer Logic and Wiring Diagram	61
F. AD-120 Tool List	62

SECTION I

Important Information

A. Safety Precautions

1. Do not store or use gasoline or other flammable vapors and liquids in the vicinity of this or any other appliance.
2. Purchaser/user should consult the local gas supplier for proper instructions to be followed in the event the user smells gas. The instructions should be posted in a prominent location.
3. Dryer must be exhausted to the outdoors.
4. Although ADC's dryer is a very versatile machine, there are some articles, that due to fabric composition or cleaning method, should not be dried in it.

| WARNING: Dry only water-washed fabrics. Do not dry articles spotted or washed in dry cleaning solvents, a combustible detergent, or "All-Purpose" cleaners. Fire or explosion could result.

| WARNING: Do not dry rags or articles coated with gasoline, kerosene, paint, or wax.

| WARNING: Do not dry mopheads. Contamination by wax or flammable solvents will create a fire hazard.

| WARNING: Do not use heat for drying articles that contain plastic, foam, sponge rubber, or similarly textured rubber-like materials. Drying in a heated tumbler may damage plastic or rubber and also may be a fire hazard.

5. A program should be established for the inspection and cleaning of lint in the burner areas and exhaust duct work. The frequency of cleaning can best be determined from experience at each location.

| WARNING: The collection of lint in the burner area and exhaust duct work can create a potential fire hazard.

6. For personal safety, the dryer must be electrically grounded in accordance with local codes and/or the National Electric Code ANSI/NFPA No. 70 (latest edition).

| NOTE: Failure to do so will void the warranty.

7. Under no circumstances should the dryer door or lint drawer switch(es) or heat safety devices ever be disabled.

| WARNING: PERSONAL INJURY OR FIRE COULD RESULT.

8. Articles should never be left unattended for an extended period of time in the basket after completion of the drying and cooling cycles.

WARNING: ARTICLES LEFT IN THE DRYER AFTER THE DRYING AND COOLING CYCLES HAVE BEEN COMPLETED CAN CREATE A FIRE HAZARD.

9. This dryer is not to be used in the presence of dry cleaning solvents or fumes.

10. Read and follow all caution and direction labels attached to the dryer.

WARNING: CHILDREN SHOULD NOT BE ALLOWED TO PLAY ON OR IN THE DRYER(S). CHILDREN SHOULD BE SUPERVISED IF NEAR DRYER(S) IN OPERATION.

11. Do not operate dryers with more than 125 PSI steam pressure. Excessive steam pressure can damage steam coil and/or harm personnel.

12. Replace leaking flexible steam hoses or other steam fixtures immediately. Do not operate dryer with leaking flexible hoses. Personal injury may result.

SECTION II

Routine Maintenance

A. Cleaning

A program and/or schedule should be established for periodic inspection, cleaning, and removal of lint from various areas of the dryer, as well as throughout the duct work system. The frequency of cleaning can best be determined from experience at each location. Maximum operating efficiency is dependent upon proper air circulation. The accumulation of lint can restrict this airflow. If the guidelines in this section are met, an ADC dryer will provide many years of efficient, troublefree, and — most importantly — safe operation.

| WARNING: LINT FROM MOST FABRICS IS HIGHLY COMBUSTIBLE. THE ACCUMULATION OF LINT CAN CREATE A POTENTIAL FIRE HAZARD.

| WARNING: KEEP DRYER AREA CLEAR AND FREE FROM COMBUSTIBLE MATERIALS, GASOLINE, AND THEIR FLAMMABLE VAPORS AND LIQUIDS.

| NOTE: Suggested time intervals shown are for average usage which is considered six (6) to eight (8) operational (running) hours per day.

Daily (beginning of each work shift).

Clean lint from the lint drawer/screen. Inspect lint screen and replace if torn.

Weekly

Clean lint accumulation from lint chamber, thermostat, and microprocessor temperature sensor (sensor bracket) area.

| WARNING: To avoid the hazard of electrical shock, discontinue electrical supply to dryer.

STEAM DRYERS

Clean steam coil fins using compressed air and a vacuum cleaner with brush attachment.

| NOTE: When cleaning steam coil fins, be careful not to bend the fins. If fins are bent, straighten by using fin comb which is available from local air conditioning supply houses.

90 DAYS

Remove lint from basket, drive motors, and surrounding areas. Remove lint from gas valve burner area with a dusting brush or vacuum cleaner attachment.

| NOTE: To prevent damage, avoid cleaning and/or touching ignitor/flame-probe assembly.

Remove lint accumulation from inside control box and at rear area behind control box.

6 Months

Inspect and remove lint accumulation in customer-furnish exhaust duct work system and from dryer internal exhaust ducting.

| WARNING: THE ACCUMULATION OF LINT IN THE EXHAUST DUCT WORK CAN CREATE A POTENTIAL FIRE HAZARD.

| WARNING: Do not obstruct the flow of combustion and ventilation air. Check customer furnished back draft in exhaust duct work. Inspect and remove any lint accumulation which can cause damper to bind or stick.

| NOTE: A back draft damper is sticking partially closed can result in slow drying and shutdown of the heat circuit safety switches or thermostats.

| NOTE: When cleaning dryer cabinet(s), avoid using harsh abrasive. A product intended for the cleaning of appliances is recommended.

B. Adjustments

7 Days after installation and every 6 months

Inspect bolts, nuts, screws (bearing set screws), non-permanent gas connections (unions, shut-off valves, orifices, and ground connections). Motor and drive belts should be examined. Cracked or seriously frayed belts should be replaced. Tighten loose V-belts when necessary. Complete operational check of controls and valves. Complete operational check of all safety devices (door switch, lint drawer switch, sail switch, burner and hi-limit thermostats).

C. Lubrication

The motor bearings, idler bearings, and basket (tumbler) bearings are permanently lubricated. No lubrication is necessary.

SECTION III

Installation Requirements

Installation should be performed by competent technicians in accordance with local and state codes. In the absence of these codes, installation must conform to applicable AMERICAN NATIONAL STANDARDS:

ANSI Z223.1 (latest edition) National Fuel Gas Code and/or

ANSI/NFPA No. 70 (latest edition) National Electric Code

A. Enclosure, Air Supply, and Exhaust Requirements

NOTE: The following information is very brief and general. For a detailed description, refer to the "AD-120 Installation Manual" (ADC part no. 112138).

Bulkheads and partitions around the dryer should be made of non-combustible materials. Allowances should be made for the opening and closing of the control door and lint drawer. Also, allowances should be made in the rear for ease of maintenance. (Refer to AD-120 Installation Manual for recommended distances and minimum allowances required.)

When the dryer is operating, it draws in room air, heats it, passes this air through the basket, and exhausts it out of the building. Therefore, the room air must be continually replenished from the outdoors. If the make-up air is inadequate, drying time and drying efficiency will be adversely affected. Ignition problems and sail switch "fluttering" problems on gas dryers may result, and you also could have premature motor failure from overheating. The air supply must be given careful consideration to insure proper performance of each dryer.

IMPORTANT: Make-up air must be provided from a source free of dry cleaning fumes. Make-up air that is contaminated by dry cleaning fumes will result in irreparable damage to motors and other dryer components.

Exhaust duct work should be designed and installed by a competent technician. Improperly sized duct work will create excessive back pressure which will result in slow drying, increased use of energy, and shutdown of the burner by the airflow (sail) switch, burner hi-limit or lint chamber hi-heat protector thermostat. (Refer to AD-120 Installation Manual for more detail.)

CAUTION: IMPROPERLY SIZED OR INSTALLED EXHAUST DUCT WORK CAN CREATE A POTENTIAL FIRE HAZARD.

B. Electrical and Gas Requirements

It is your responsibility to have all electrical connections made by a properly licensed and competent electrician to assure that the electrical installation is adequate and conforms with local and state regulations or codes. In the absence of such codes, all electrical connections, material, and workmanship must conform to the applicable requirements of the NATIONAL ELECTRIC CODE ANSI/NFPA No. 70 (latest edition).

IMPORTANT: Failure to comply with these codes or ordinances and/or the requirements stipulated in this manual can result in personal injury or componet failure.

The gas dryer installation must meet the AMERICAN NATIONAL STANDARD, NATIONAL FUEL GAS CODE ANSI Z223.1 (latest edition), as well as, local codes and ordinances, and must be done by a qualified technician.

NOTE: Undersized gas piping will result in ignition problems and slow drying and can create a safety hazard.

The dryer must be connected to the type of gas (natural or L.P.) indicated on the dryer data label. If this information does not agree with the type of gas available, contact the distributor who sold the dryer or contact the factory.

The gas input ratings shown on the dryer data label are for elevations up to 2,000 feet, unless elevation requirements of over 2,000 feet were specified at the time the dryer order was placed with the factory. The adjustment for dryers in the field for elevations over 2,000 feet are made by changing the burner orifices. If this adjustment is necessary, contact the distributor who sold the dryer or contact the factory.

NOTE: Any burner changes must be made by a qualified technician.

C. Operational Service Check Procedure

1. Turn on electric power to dryer.
2. To start dryer:
 - a. Display will read "FILL."
 - b. Press "E" touch pad on keyboard of microprocessor controller (computer).

c. Display will quickly read "Ld30," "LC04," "F180." The dryer will start, and the display will show "dr30."

NOTE: Pressing touch pads "A," "B," "C," "D," and "F" will also start the dryer. Six (6) preprogrammed drying cycles ("A" through "F") have been stored in the computer's memory. (See Computer Operators Manual for details.)

3. Make a complete operational check of all the operating controls to assure that the timing is correct, temperature selection switches are functioning, etc.
4. Make a complete operational check of all safety-related circuits - door switch(es), hi-limit thermostat, sail switch, cycling thermostats, etc.
5. For gas dryers a gas pressure test should be taken at the gas valve pressure tap of each dryer to assure that the water column pressure is correct and consistent.

NOTE: Water column pressure requirements (measured at the pressure tap on the gas valve body):

Natural Gas - 3.5 - 4 Inches Water Column

L.P. Gas - 10.5 - 11 Inches Water Column

6. If computer program changes are required, refer to the Phase 4 OPL Operator's Manual (ADC part no. 112120) for details.
7. The dryer should be operated through one complete cycle to assure that no further adjustments are necessary and that all components are functioning properly.
8. Check the electric service phase sequence. While the dryer is operating, check to see if the blower wheel is rotating in the proper direction. Looking from the front, the blower wheel should spin in the counterclockwise direction. If so, the phasing is correct. If the phasing is incorrect, reverse two (2) leads at connections L1, L2, or L3 of power supply to the dryer.

SECTION IV

Description of Parts

A. Control Box

Lifting the control door and opening the computer panel will reveal the control box. Inside the control box are all the electronic control components. Located on the back of the control panel is the computer. Included in the control box are the 30-position block, fuse block, and transformer.

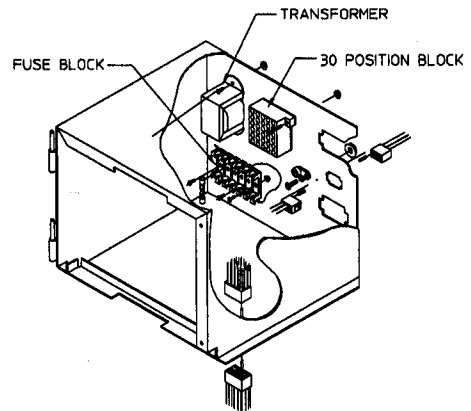

MAN0461

B. DSI Module (Gas Models Only)

The DSI system consists of a microprocessor-based control module, along with an ignitor/flame-probe assembly. This control utilizes a high voltage synchronous spark ignitor and a rectified flame sensor/probe signal to locally control all basic functions in the gas burner.

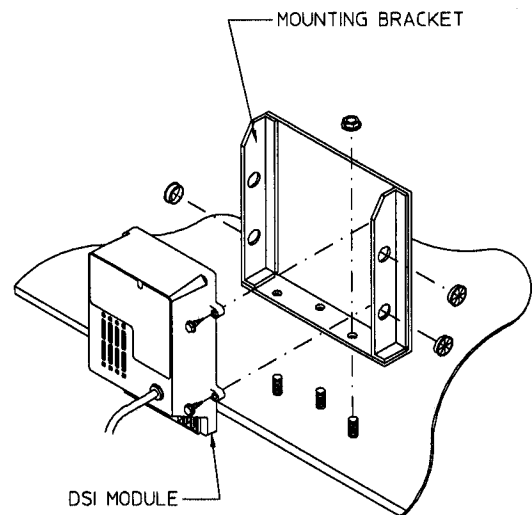

C. Gas Burner Assembly

Gas-heated dryers are equipped with a gas burner assembly consisting of three (3) burner tubes, gas valve, spark ignition probe assembly, sail switch, and hi-limit thermostat. The inlet piping enters through the rear of the dryer on the left-hand side (viewing from the front) and runs to the front of the dryer where the gas valve is located.

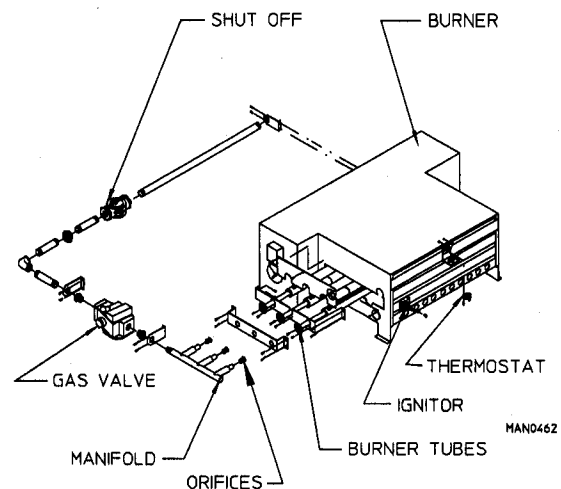

MAN0462

D. Drive Motor

The T.E.F.C. (totally enclosed, fan-cooled) drive motor is located on the back approximately lower center of the dryer. It sits on an adjustable base so that the motor can be easily adjusted to the left or right, up or down, forward or backward. The drive motor is a 3/4 HP motor and operates on 208 to 460 volts, 50/60 hertz, 3-phase.

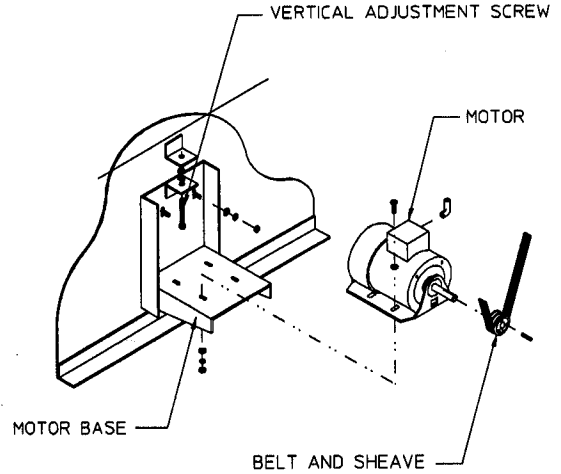

MAN0480

E. Blower Motor and Impellor

(Viewing from the front of the dryer) the blower motor is located on the back of the dryer at the lower right-hand corner. The impellor is a backward curved paddle wheel which is directly connected to the shaft of the blower motor. The blower motor is a 3 HP motor and operates on 208 to 460 volts, 50/60 hertz, 3-phase.

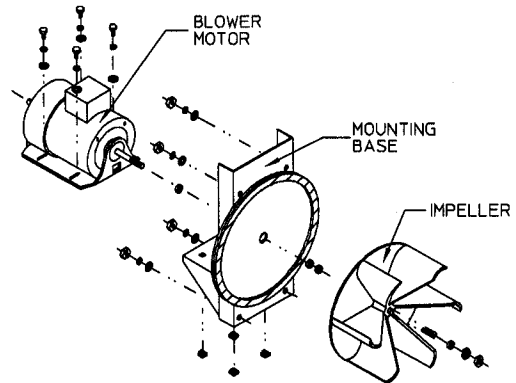

F. Idler Assembly

(Viewing from the rear of the dryer) the idler assembly is located approximately on the lower center of the dryer. The idler assembly consists of two (2) idler pulleys, the small and large pulleys. The idlers' main purpose is to reduce the speed and increase torque provided to the tumbler bearing. Also, at the idler assembly, belt tension can be adjusted.

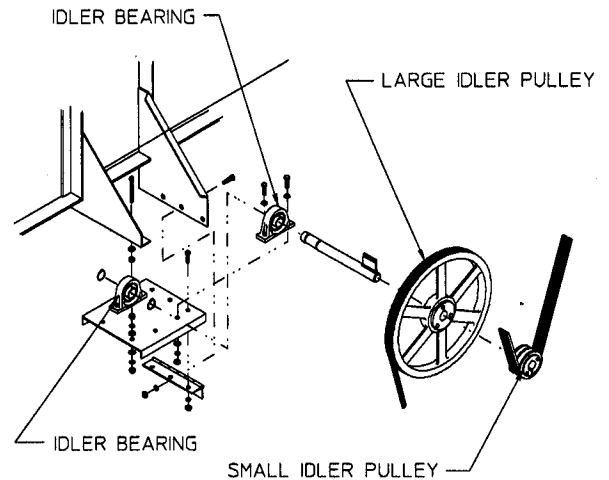

MAN048'

G. Tumbler Bearing and Pulley Arrangement

The tumbler bearing and pulley arrangement is located (viewing from the rear of the dryer) approximately at the upper center of the dryer. The arrangement consists of a pulley and two (2) bearings which serve to drive, adjust, and support the basket.

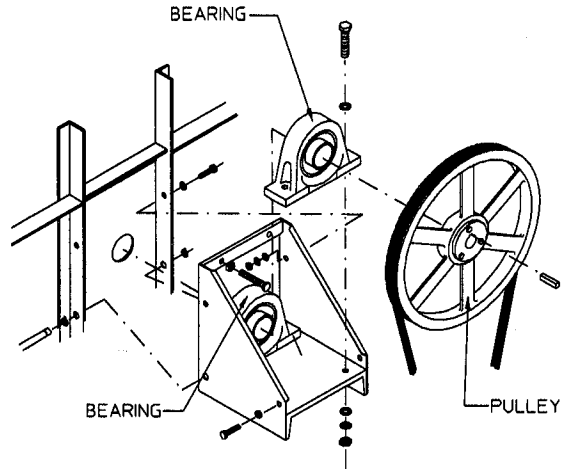

MAN0536

H. Basket (Tumbler)

The basket consists of four (4) ribs and four (4) perforated panels, along with a front and back, which are screwed together as an assembly. The basket also consists of tie rods, which support the basket from front to back. The basket support is used to mate the basket to the drive system in the rear.

I. Main Door Switch

The main door switch is located in the main door hinge block. When the main door opens, the switch will also open, preventing the dryer from operating. The main door switch is a safety device and should never be disabled.

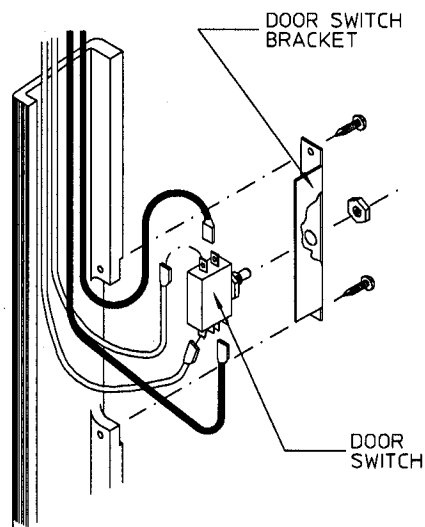

MAN0544

J. Sail Switch (Gas Models Only)

The sail switch is located on the front of the burner. A sail switch consists of a round damper plate on a lever arm which is in contact with an electric switch. When the air blower comes on, it draws air through the gas burner. This creates a negative pressure inside the burner box, and this negative pressure pulls in the round damper and activates the sail switch. If there is improper airflow, the damper will not pull in, preventing the burner from coming on.

Improper airflow can be caused by improperly designed exhaust ducting where the duct run is too long or has too many sharp bends in it. It can also be caused by lack of make-up air.

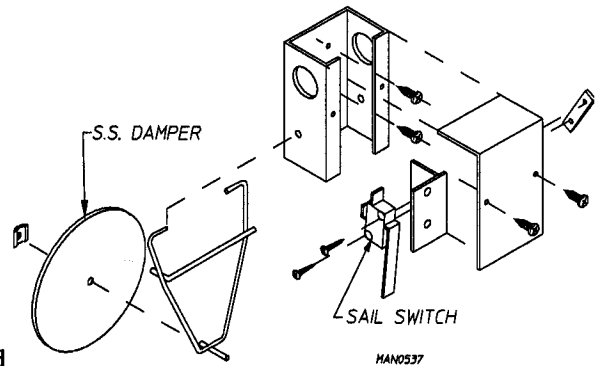

K. Hi-Limit (Gas Models Only)

A hi-limit thermostat is located at the gas burner. This is an automatically reset disc-type thermostat set at 330°F. If the flame in the burner should get too hot, this thermostat will shut off the burner. This is generally caused by low airflow through the dryer.

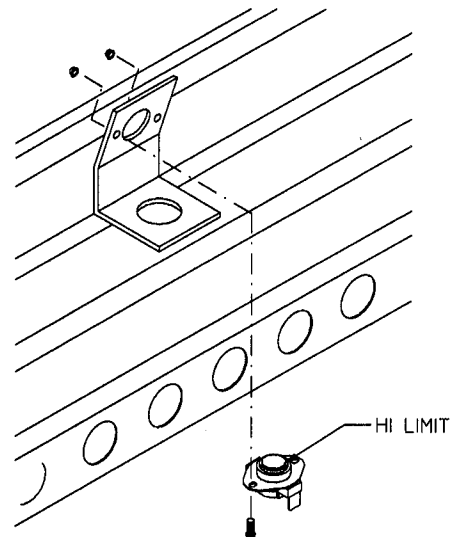

L. Automatic Reset Thermostat

This is located inside the dryer in the lint compartment above the lint drawer. This thermostat senses the heated air after it has passed through the basket. If the air temperature gets too hot, the thermostat will shut off the burner. The dryer will not run until the air temperature cools down. At this time, the thermostat will reset. Basket and blower will run, but dryer will not heat.

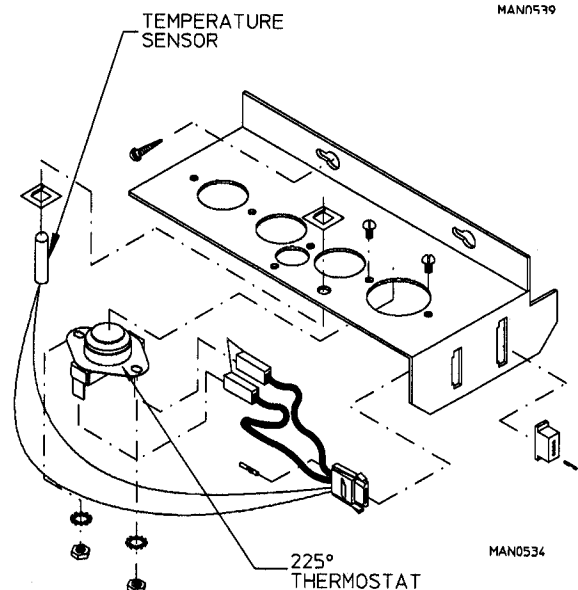

M. Lint Drawer

The lint drawer is a pull-out type and is located at the bottom of the dryer in the lint compartment. Simply grab the lint drawer handle, slide out the drawer, brush off the lint, and slide the drawer back in. The lint screen must be kept clean in order for the dryer to operate properly and efficiently.

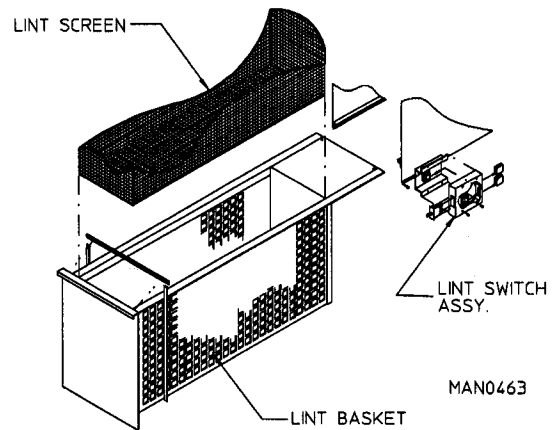

N. Lint Drawer Switch

The lint drawer switch is located in the lint compartment and attached to the side of the lint drawer track. The lint drawer switch insures that the dryer will operate only when the lint drawer is completely closed. This is a safety device and should never be disabled.

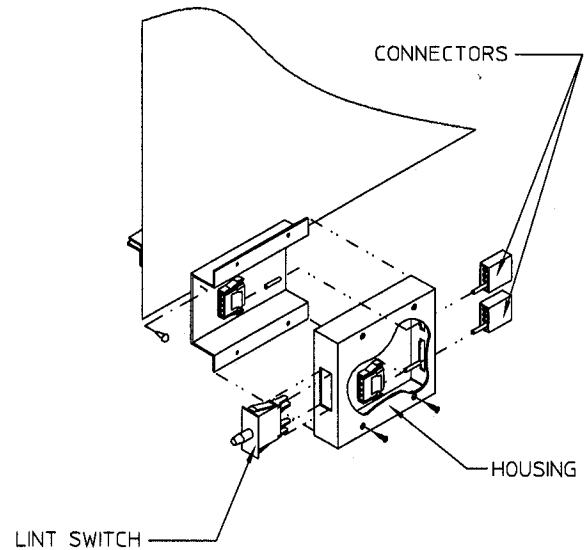

O. Steam Damper System

The newest type system is called the steam damper, it is shown to the right and it uses a piston with compressed air to open and close the steam damper which in turn allows the air to flow freely or to block off air flow. Air supply is 80 P.S.I. +/- 10 P.S.I.

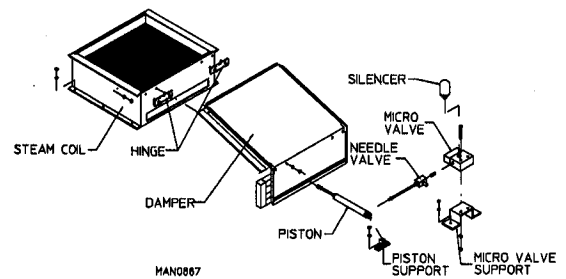

SECTION V

Servicing

Introduction

All electrical/mechanical service or repairs should be made with the electrical power to the dryer disconnected (power off).

| WARNING: PERSONAL INJURY COULD RESULT.

The information provided in this section should not be misconstrued as a device for use by an untrained person making repairs. Service work should be performed by competent technicians in accordance with local, state, and federal codes.

When contacting the factory for assistance, always have the dryer model and serial numbers available.

| CAUTION: Observe all safety precautions displayed on the dryer or specified in this manual before and while making repairs.

Before considering replacement, make sure that all connectors are in place and making proper contact. Check input voltages and temperature sensor.

A. Computer Controls

To Replace Computer Control Panel

1. Disconnect power to dryer.
2. Disconnect main power harness from rear of computer by squeezing locking tabs and pulling connector straight back.
3. Disconnect the green ground wire from the computer.
4. Disconnect the two (2) wires from the HI and HO terminals of the computer.
5. To remove control panel assembly from control box, gently tap the bottom of the control panel upward and lift off the hinges.
6. Install new control panel assembly by reversing this procedure.
7. When replacing the computer, the "A" and "B" factors must be reprogrammed. (see Computer Operator's Manual for details)

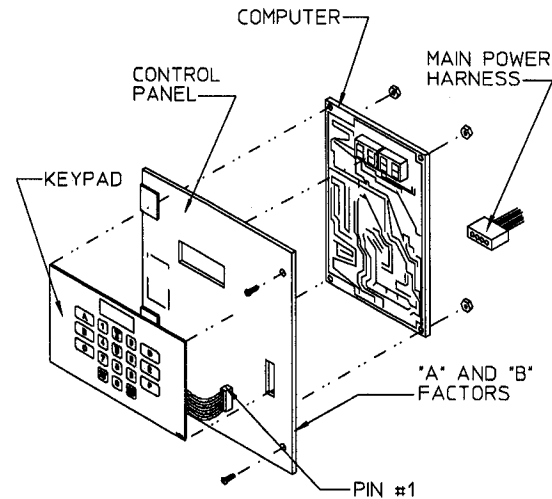

NOTE: The "A" and "B" factors are printed on a label located on the rear of the control panel. (refer to illustration above).

8. Reestablish power to dryer.

To Replace Computer

1. Disconnect power to dryer.
2. Disconnect main power harness from rear of computer by squeezing locking tabs and pulling connector straight back.
3. Disconnect the green ground wire from the computer.
4. Disconnect the two (2) wires from the HI and HO terminals of the computer.
5. Disconnect keyboard ribbon from computer.
6. Remove the four (4) hex nuts securing the computer to the sheet metal control panel and disassemble computer from panel.

7. Install new computer by reversing this procedure.
8. When replacing the computer, the "A" and "B" factors must be reprogrammed. (see "Computer Operator's Manual" for details)

NOTE: The "A" and "B" factors are printed on a label located on the rear of the control panel (see illustration).

9. Reestablish power to dryer.

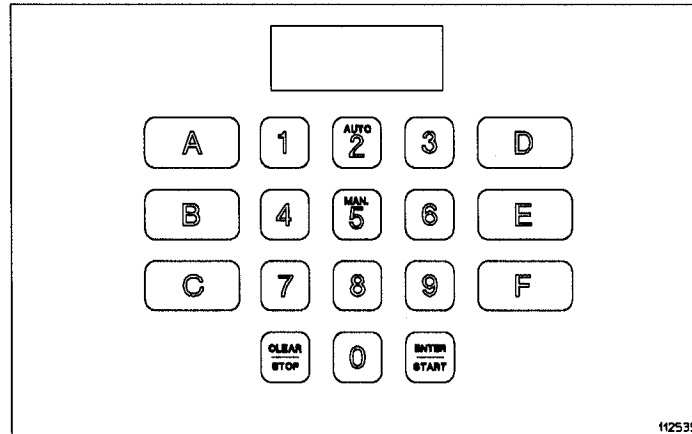

To Replace Keyboard Label Assembly

MAN0550

1. Discontinue power to dryer.
2. Unplug keyboard ribbon from rear of computer.
3. Slowly peel off and remove keyboard label assembly from control panel.
4. Peel paper backing off new keyboard label assembly.
5. Holding the new keyboard label assembly close to the control panel, insert the keyboard ribbon through the rectangular slot in the control panel. Align label assembly into position by matching the red viewing window on the label to the rectangular cutout in the panel and gently press into place.
6. Connect keyboard ribbon to computer.
7. Reestablish power to dryer.

To Replace Microprocessor Temperature Sensor Probe

1. Discontinue power to dryer.
2. Remove microprocessor sensor bracket assembly from dryer.
 - a. Disconnect sensor bracket harness connector.
 - b. Loosen the two (2) phillips head screws securing bracket assembly to dryer and remove bracket from dryer.

NOTE: Do not remove screws.

3. Disassemble sensor probe from bracket assembly by removing the top push-on fastener, securing the probe to the bracket. Use a small screwdriver to slowly pry the fastener off.

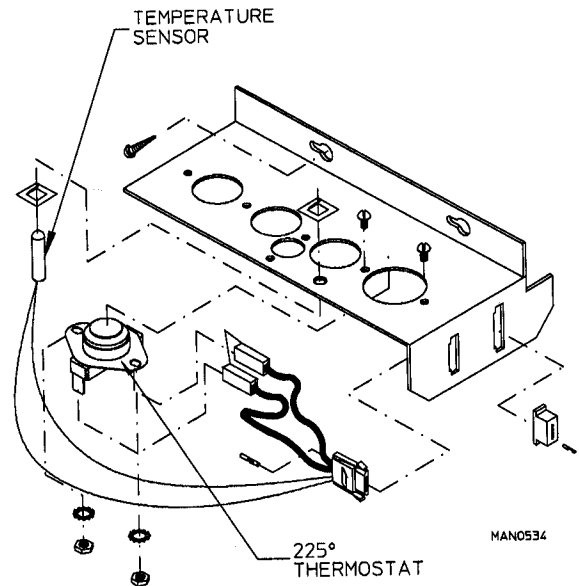

4. Disconnect the two (2) orange wires from the high heat (225 degree) temperature sensor, remove modular bracket connector, wires, and probe from bracket assembly.
5. Install new sensor probe assembly (ADC P/N 880251) by reversing procedure.
6. Reestablish power to dryer.

NOTE: If, when power is reestablished, the computer display reads "dSFL," check for a loose connection in the wiring.

B. Ignition Controls

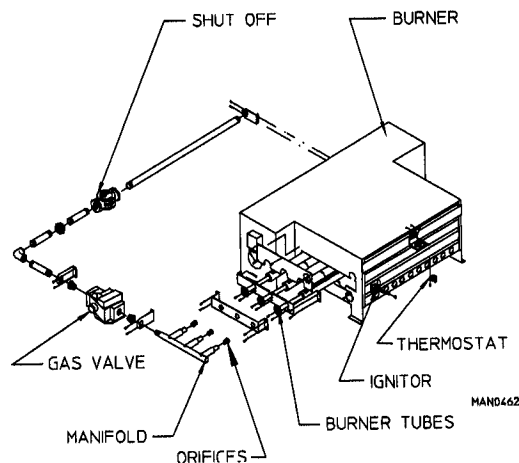

To Remove Spark Ignitor

1. Discontinue power to dryer.
2. Disconnect HV connector and flame probe connection from ignitor.
3. Disassemble ignitor from burner by removing the two (2) self-tapping screws.
4. Reverse procedure for installing new ignitor/flame-probe.

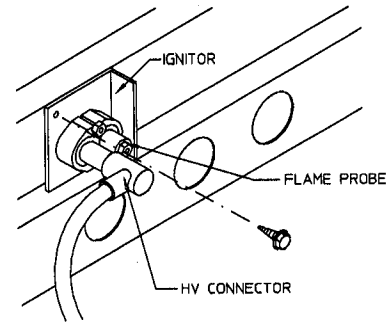

NOTE: Before reestablishing power to dryer, visually check the following (see illustration):

1. The flame electrode, ignitor electrode, and ground rod are all on the same line of axis.
2. There should be a $1/8$ gap ($\pm 1/32$) between the ignitor electrode and ground rod.
3. Do not wrap the red HV wire and the flame electrode wire together. Improper operation may result. They may run alongside each other.

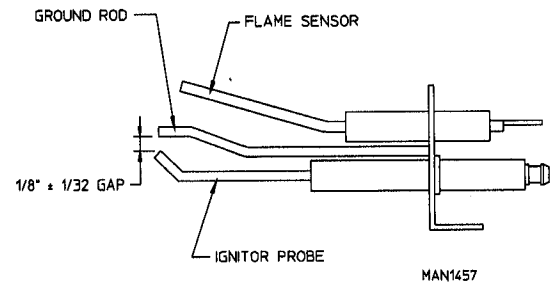

To Replace Gas Valve (See burner illustration on page 16)

1. Discontinue power to dryer.
 2. Close shut-off valve(s) in gas supply line.
 3. Disconnect gas valve wiring.
- NOTE:** Identify location of each wire for correct reinstallation.
4. Break union connection before gas valve.
 5. Loosen and remove screws (4) securing pipe brackets to burner.
 6. Remove gas valve/manifold assembly from dryer.
 7. Remove valve mounting bracket, manifold, and piping from gas valve.
 8. Remove union tailpiece from valve (incoming gas side).
 9. Reverse procedure for installing new gas valve.

WARNING: Test all connections for leaks by brushing on a soapy water solution. NEVER TEST FOR LEAKS WITH A FLAME.

To Replace Main Burner Orifices

1. Refer to "To Replace Gas Valve" and follow steps 1 through 6.
2. Unscrew main burner orifices and replace.

NOTE: Use extreme care when removing and replacing orifices. These orifices are made of brass and are easily damaged.

3. Reversing the removal procedure for reinstalling.

NOTE: Test all connections for leaks by brushing on a soapy water solution. NEVER TEST FOR LEAKS WITH A FLAME.

To Test and Adjust Gas (Water Column) Pressure

There are two (2) types of devices commonly used to measure water column pressure. They are spring/mechanical-type gauges and manometers. The spring/mechanical-type gauge is not recommended, because it is easily damaged and not always accurate. A manometer is simply a glass or transparent plastic tube with a scale in inches. When filled with water and pressure applied, the water in the tube rises showing the exact water column pressure.

NOTE: Manometers are available from the factory by ordering ADC P/N:122804

1. To Test Gas Water Column (W.C.) Pressure:

- a. Connect water column test gauge connection to gas valve pressure tap (1/8" NPT). This pressure tap is located on the outlet (downstream) side of the valve.
- b. Start dryer. With burner on, the correct water column reading in inches would be:

Natural Gas - 3.5 to 4 Inches Water Column
L.P. Gas - 10.5 to 11 Inches Water Column

2. To Adjust Water Column Pressure (natural gas only, L.P. gas must be adjusted at source):

- a. Turn the slotted adjustment screw located on top of the valve next to the terminals. Turn clockwise to increase manifold pressure and counterclockwise to decrease.

NOTE: If correct W.C. pressure cannot be achieved, problem may be due to an undersized gas supply line, a faulty or underrated gas meter, etc.

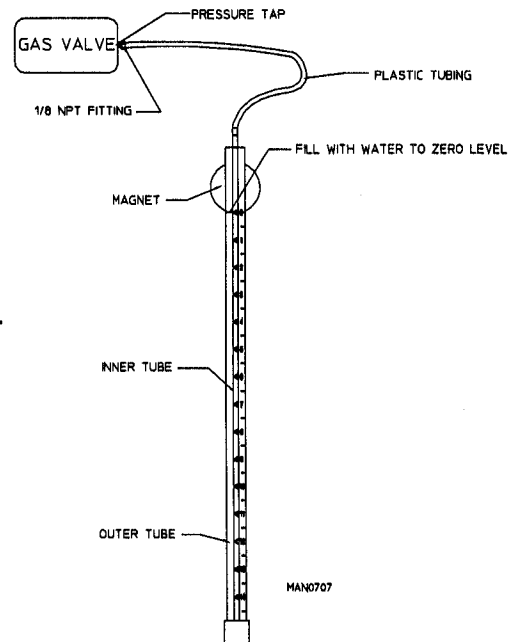

To Convert from Natural Gas to L.P. Gas

NOTE: All dryers are sold as natural gas. For L.P. gas the dryer must be converted as follows.

Parts required for conversion: L.P. Kit P/N 880491. (For butane gas or elevations over 2,000 feet, contact factory.)

1. Refer to "Replace Gas Valve" and follow steps 1 through 8.
2. Remove the four (4) screws which secure the top valve assembly. This assembly contains the regulator adjustment screw and the terminal connections.
3. Replace the top valve assembly with the L.P. version.
4. Unscrew main burner orifices and replace with L.P. orifices

NOTE: Use extreme care when removing and replacing orifices. These orifices are made of brass and are easily damaged.

5. Reverse the procedure for reinstalling valve assembly to the dryer.

WARNING: Test all connections for leaks by brushing on a soapy water solution. NEVER TEST FOR LEAKS WITH A FLAME.

NOTE: There is no regulator provided in an L.P. dryer. The column pressure must be regulated at the source (L.P. tank) or an external regulator must be added to each dryer.

To Replace Burner Tubes

1. Refer to "Replace Gas Valve" and follow steps 1 through 8.
2. Remove four (4) screws securing manifold rest and remove rest.
3. Remove the screws securing the front flanges of the burner tubes to the burner tube rest.
4. Remove the screws securing the burner tube rest to the oven and remove this rest.
5. Remove screws securing the sight hole disk and burner box cover plate to the oven and remove both of these pieces.

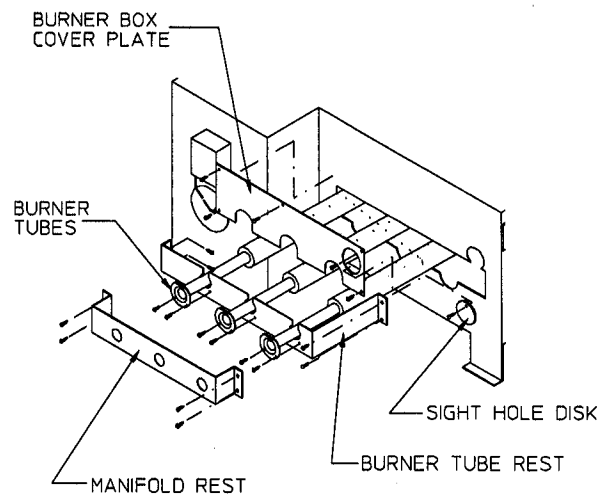

MAN054C

6. Remove burner tubes by sliding them out.
7. Replace by reversing procedure.

WARNING: Test all connections for leaks by brushing on a soapy water solution. NEVER TEST FOR LEAKS WITH A FLAME.

To Replace DSI Module

1. Discontinue power to the dryer.
2. Remove the wires connected to the terminal strip at the bottom of the module.
3. Remove the four (4) screws securing the module to the ignition control panel.
4. Replace module by reversing process.
5. Reestablish power to dryer.

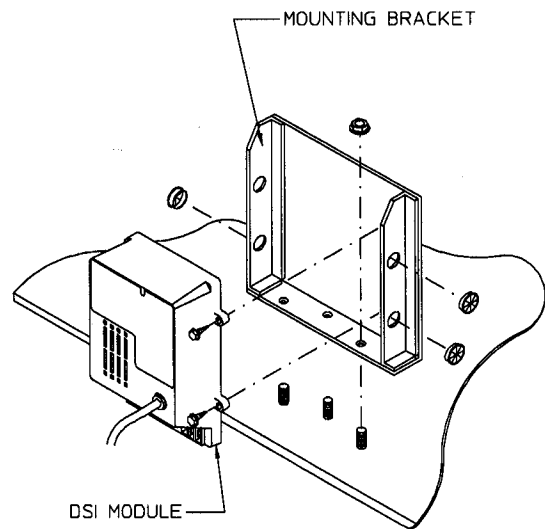

MAN0460

C. Thermostats

To Replace Burner Hi-Limit (330 Degrees) Thermostat (Gas Models Only)

This thermostat is an important safety device serving as an added protection against failure of the air sail switch to open in the event of motor failure or reduced airflow condition.

IMPORTANT: Under no circumstances should heat circuit safety devices ever be disabled.

1. Discontinue power to dryer.
2. Disconnect wires from hi-limit thermostat.
3. Remove screw, washer, and nut securing thermostat to the bracket. Remove thermostat.
4. Reverse procedure for installing new thermostat.
5. Reestablish power to dryer.

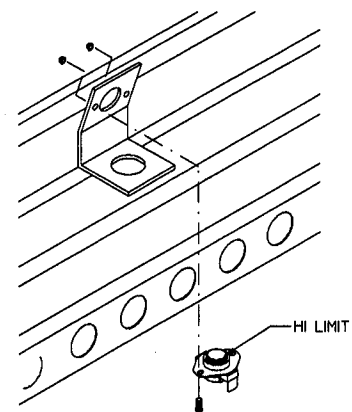

MAN0535

To Replace Lint Compartment Hi-Heat Protector (225 Degree) Thermostat

This thermostat is part of the "sensor bracket assembly" and is secured to the underside of the basket wrapper on the lint compartment. As a safety device, this thermostat will open (shut off) the heating unit circuit if an excessive temperature occurs. The dryer motors will remain on, even if the thermostat is open.

| IMPORTANT: Under no circumstances should heat safety devices be disabled.

1. Discontinue power to dryer.
2. Remove lint drawer. Remove two (2) screws securing lint door and remove lint door.
3. Locate sensor bracket assembly and loosen the two (2) Phillips head screws securing bracket assembly to the tumbler wrapper.

| NOTE: Do not remove the screws.

4. Remove bracket assembly by slightly sliding bracket towards the rear of the dryer and to the left.
5. Disconnect sensor bracket harness connector and remove bracket assembly from dryer.
6. Disconnect the two (2) orange wires from thermostat.
7. Disassemble thermostat from bracket assembly by removing the two (2) mounting screws, washers, and nuts.
8. Reverse this procedure for installing hi-heat protector thermostat.
9. Reestablish power to dryer.

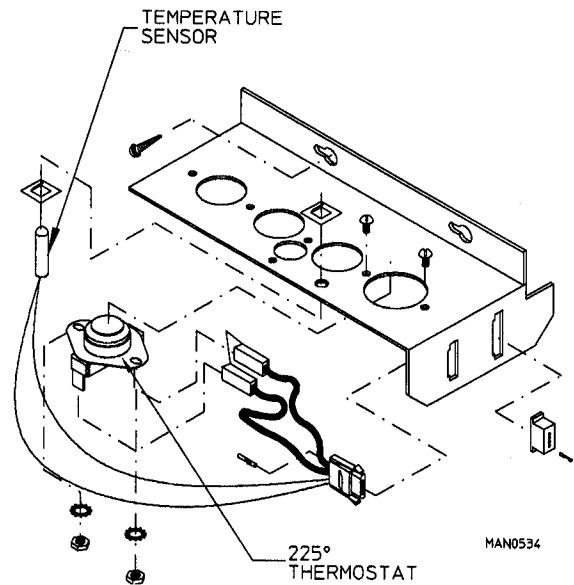

D. Sail Switch Assembly (Gas Models Only)

The sail switch is a heat circuit safety device which controls the burner circuit only. When the dryer is operating and there is proper airflow, the sail switch damper pulls in and closes the sail switch. Providing all the other heat-related circuits are functioning properly, ignition should now be established. If an improper airflow occurs, the sail switch damper will release, and the circuit will open.

| IMPORTANT: Under no circumstances should heat circuit safety devices ever be disabled.

To Replace Sail Switch

1. Discontinue power to dryer.

2. Remove the two (2) screws which hold sail switch box cover to sail switch box.
3. Disconnect the two (2) wires from switch.
4. Disassemble sail switch from mounting bracket by removing the two (2) screws securing switch in place.
5. Reverse this procedure for installing new sail switch. Adjust sail switch as described in the next section.

To Adjust Sail Switch

With the dryer operating at a high temperature setting, pull the sail switch damper away from the burner. The sail switch should open and extinguish the burner. Let the sail switch damper return to the burner wall. The sail switch should close to restart the burner ignition cycle. If the sail switch circuit does not operate as described, bend the actuator arm of the sail switch accordingly until proper operation is achieved. To check proper "open" position of sail switch, open main door, manually depress main door switch, and start dryer. With the main door open and the dryer operating, the sail switch circuit should be open, and the burner should not come on.

CAUTION: Do not abort this switch by taping or screwing sail switch damper to burner. PERSONAL INJURY OR FIRE COULD RESULT.

E.. Front Panel and Main Door Assemblies

To Replace Main Door Switch

1. Discontinue power to dryer.
2. Open main door.
3. Remove the two (2) phillips head screws holding the main door switch bracket assembly in place.
4. Remove door switch bracket from hinge block and disconnect wiring from switch.

NOTE: Identify location of each wire for correct reinstallation.

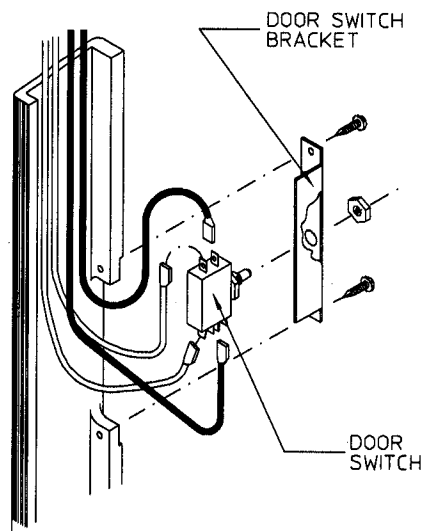

5. Disassemble door switch bracket by removing locking adjustment nut. Remove second locking nut and assemble onto new door switch.
6. Reverse this procedure for installing new door switch.
7. Reestablish power to dryer.

IMPORTANT: Under no circumstance should the door switch be disabled.

NOTE: When reconnecting wires to door switch, be sure wiring sequence is correct.

To Replace Main Door Assembly

1. Remove screws holding main door to main door hinge pad.
2. Reverse this procedure for reinstalling new main door assembly.

To Install New Main Door Glass

1. Remove main door assembly from dryer (follow main door removal procedure).
2. Lay main door on flat surface with front of door face down.
3. Remove glass and clean all old sealant off main door. This area must be completely cleaned for correct bonding.
4. Apply a narrow bead of silicone (ADC P/N 170730) all around main door area where glass will rest.
5. Install glass onto door/adhesive and slightly press glass in place.

IMPORTANT: Do not press hard or silicone thickness between the glass and door will be reduced, resulting in poor bonding.

6. The door assembly should now be put in an area where it will not be disturbed for at least 24 hours. Depending on the conditions, the curing time of this adhesive is 24 to 36 hours.
7. After 24-hour curing period, install main door on dryer by reversing step 1.

To Replace Front Panel

1. Discontinue power to dryer.

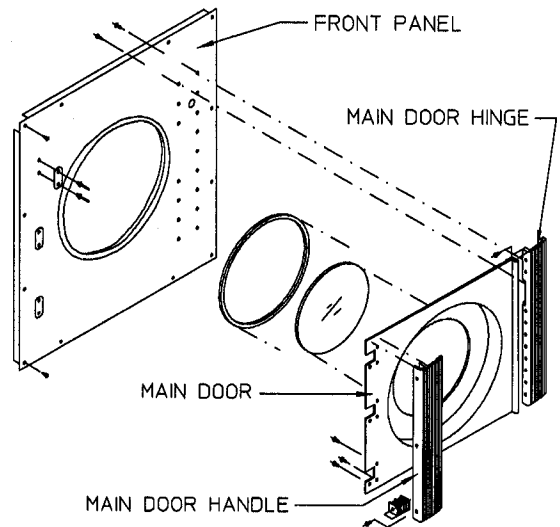

MANR54F

2. Disconnect main door switch wiring from the door switch.

NOTE: Identify location of each wire for correct reinstallation.

3. Follow procedure for removal of main door assembly.
4. Open control (service) door.
5. Remove lint drawer and open lint door by removing two (2) screws.
6. Remove the twelve (12) Phillips head screws securing front panel to dryer.
7. Pull wires up through front panel door switch wire channel and gently remove front panel assembly.
8. Reverse this procedure for installing new front panel.
9. Reestablish power to dryer.

To Replace Main Door Hinge Pad

1. Discontinue power to dryer.
2. Follow procedure for removal of main door assembly.
3. Follow procedure for removal of front panel assembly.
4. Disassemble hinge pad from front panel by removing the Phillips head screws located on the back side of the front panel, which hold the hinge pad to the front panel.

IMPORTANT: When removing hinge pad assembly from front panel, be careful not to damage main door switch wires.

5. Remove main door switch, wires, and spacer nuts from hinge pad assembly.
6. Reassemble by reversing removal procedure.

NOTE: When connecting wires to door switch, be sure wiring sequence is correct.

7. Reestablish power to dryer.

F. Pulleys

To Replace Tumbler Pulley (20")

1. Loosen V-belts. Then, rotate pulley and roll V-belts out of grooves.
2. Remove cap screws.
3. Insert cap screws in tapped removal holes and tighten evenly until bushing becomes loose on shaft. See figure "A."
4. Remove bushing, pulley, and key.
5. Assemble bushing and sheave as shown in figure "B." When cap screws are loosely inserted, bushing remains fully expanded to provide a sliding fit on the shaft.
6. Insert key on the shaft, then slide sheave to desired position with cap screw heads to the outside.
7. Tighten cap screws progressively. There should remain a gap between the sheave hub and the flange of the bushing.

IMPORTANT: Tighten screws evenly and progressively. Never allow the sheave to be drawn in contact with the flange of the bushing. This gap should measure from 1/8" to 1/4". Proper cap screw torque is 30 ft-lbs., if greater tightening forces are applied, excess pressures will be created in the hub of the mounted sheave which may cause it to crack.

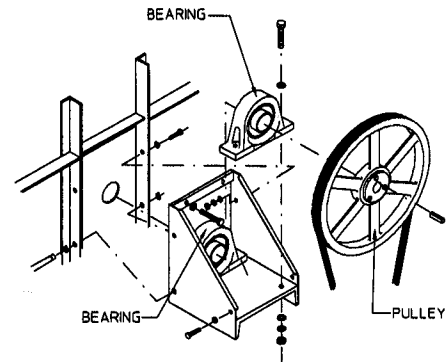

MAN0536

A

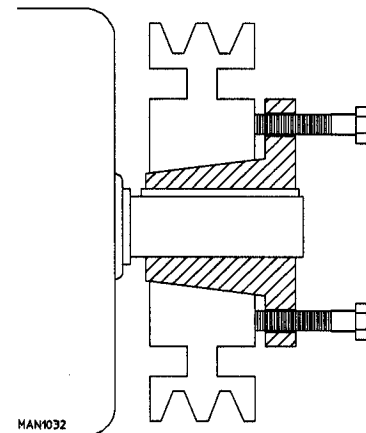

B

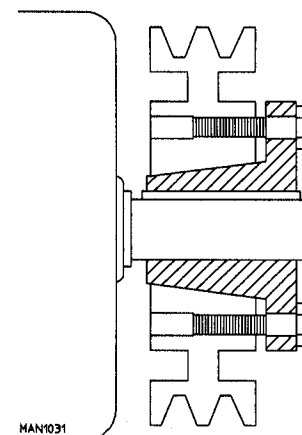

To Replace Small Idler Pulley

1. Loosen V-belts. Then, rotate pulley and roll V-belts out of grooves.
2. Remove cap screws.
3. Insert cap screws in tapped removal holes and tighten evenly until bushing becomes loose on shaft. See figure "A."
4. Remove bushing and pulley.
5. Assemble bushing and sheave as shown in figure "B." When cap screws are loosely inserted, bushing remains fully expanded to provide a sliding fit on the shaft.

6. Insert key on the shaft, then slide sheave to desired position with cap screw heads to the outside.
7. Tighten cap screws progressively. There should remain a gap between the sheave hub and the flange of the bushing.

IMPORTANT: Tighten screws evenly and progressively. Never allow the sheave to be drawn in contact with the flange of the bushing. This gap should measure from 1/8" to 1/4". Proper cap screw torque is 6 ft-lbs., if greater tightening forces are applied, excess pressures will be created in the hub of the mounted sheave which may cause it to crack.

To Replace Large Idler Pulley

1. Loosen V-belts. Then, rotate pulley and roll V-belts out of grooves.
2. Remove cap screws.
3. Insert cap screws in tapped removal holes and tighten evenly until bushing becomes loose on shaft. See figure "A" on previous page.
4. Remove bushing, pulley, and key.

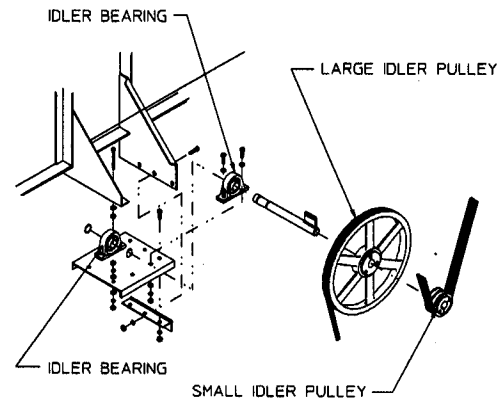

MAN0481

5. Assemble bushing and sheave as shown in figure "B" on previous page. When cap screws are loosely inserted, bushing remains fully expanded to provide a sliding fit on the shaft.
6. Insert key on the shaft, then slide sheave to desired position with cap screw heads to the outside.
7. Tighten cap screws progressively. There should remain a gap between the sheave hub and the flange of the bushing.

IMPORTANT: Tighten screws evenly and progressively. Never allow the sheave to be drawn in contact with the flange of the bushing. This gap should measure from 1/8" to 1/4". Proper cap screw torque is 15 ft-lbs., if greater tightening forces are applied, excess pressures will be created in the hub of the mounted sheave which may cause it to crack.

To Replace Motor Pulley

1. Loosen V-belts. Then, rotate pulley and roll V-belts out of grooves.
2. Remove cap screws.
3. Insert cap screws in tapped removal holes and tighten evenly until bushing becomes loose on shaft. See figure "A" on previous page.

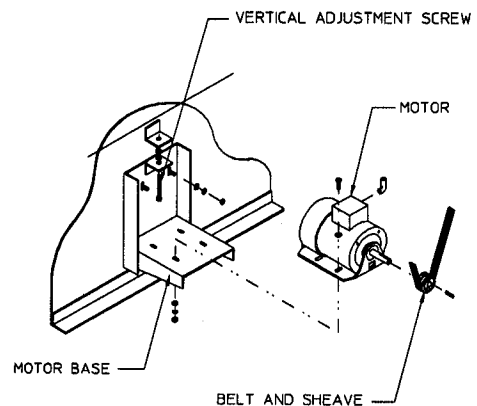

4. Remove bushing, pulley, and key.
5. Assemble bushing and sheave as shown in figure "B." When cap screws are loosely inserted, bushing remains fully expanded to provide a sliding fit on the shaft.
6. Insert key on the shaft, then slide sheave to desired position with cap screw heads to the outside.
7. Tighten cap screws progressively. There should remain a gap between the sheave hub and the flange of the bushing.

IMPORTANT: Tighten screws evenly and progressively. Never allow the sheave to be drawn in contact with the flange of the bushing. This gap should measure from 1/8" to 1/4" . Proper cap screw torque is 6 ft-lbs., if greater tightening forces are applied, excess pressures will be created in the hub of the mounted sheave which may cause it to crack.

G. Basket Assembly

Basket Alignment (Vertical) (Up and Down Adjustment)

1. Discontinue power to dryer.
2. Remove backguard.
3. Loosen the two (2) vertical holding bolts on the sides at the top of the bearing box. (1 on each side).
4. Back off jam nuts on vertical adjustment bolts.
5. Turn these bolts clockwise evenly to raise basket or counterclockwise evenly to lower basket.
6. Rotate basket from front and check alignment with front door opening.
7. Leave a larger gap from the inside ring on the top of the front panel opening to the basket and a smaller gap on the bottom to compensate for the weight of the clothes when dry.

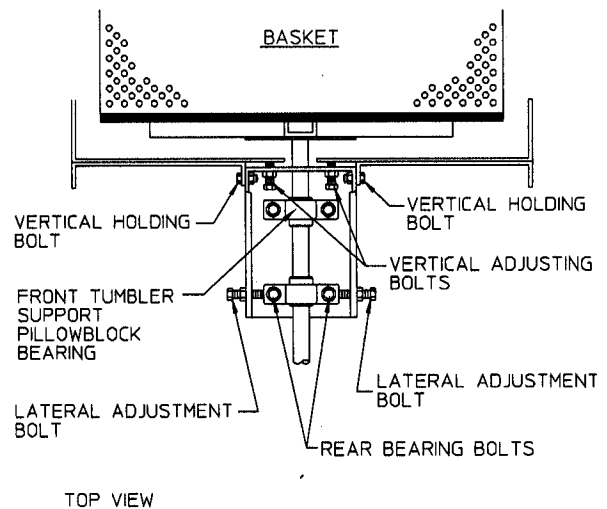

MAN055

8. Retighten the two (2) vertical holding bolts on the sides at the top of the bearing box and the jam nuts on the two (2) vertical adjustment bolts.
9. Check basket drive belt for proper tension. Adjust if necessary. (Refer to Section I, page 31 and 32)
10. Replace back guard and reestablish power to dryer.
11. Reestablish power to dryer.

Basket Alignment (Lateral) (Side to Side Adjustment)

1. Discontinue power to dryer.
2. Remove backguard.
3. Loosen rear pillow block bearing bolts (C).
4. Back off jam nuts on the two (2) lateral adjustment bolts (A) and (B).
5. Simultaneously loosen one bolt and tighten the other. This will move the rear pillow block. Center the basket in the wrapper cavity.
6. Tighten and secure both lateral adjustment bolts (A) and (B) and jam nuts.
7. Tighten pillow block bearing bolts (C) loosened in step 3.
8. Replace back guard.
9. Reestablish power to dryer.

To Replace Tumbler (Basket) or Tumbler (Basket) Support

1. Discontinue power to dryer.
2. Follow procedure for removal of main door assembly.
3. Follow procedure for removal of front panel assembly.
4. Remove back guard.
5. Remove tumbler belts.
6. Remove basket pulley (20").
7. Remove basket assembly and support.

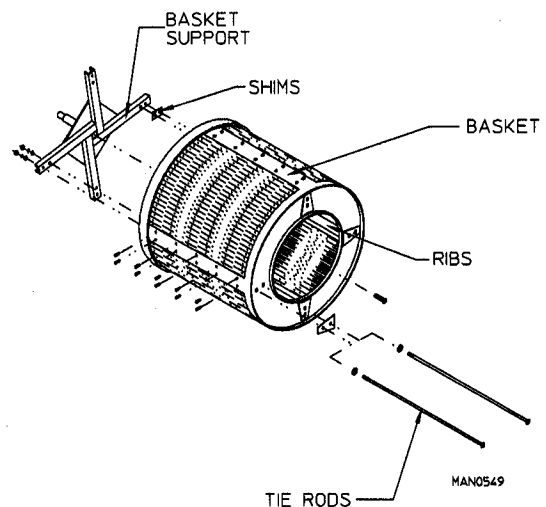

- a. Loosen the two (2) set screws on both the pillow block bearing collars.
- b. Remove the basket and support assembly from the front of the dryer. If the basket cannot be removed freely, clean the shaft area and spray WD-40 or similar lubricant. With a block of wood against the shaft end, strike the block of wood with a hammer or mallet to move the shaft past any burrs made by the set screws.

| IMPORTANT: Never strike the shaft directly with a hammer.

7. Remove basket from basket support.
 - a. Remove the bolt in the center of the basket back wall.
 - b. Loosen and remove the four (4) sets of nuts and washers from basket tie rods. Remove tie rods (8).
 - c. Replace either basket or basket support by reversing procedure.

| NOTE: Shims might be needed between tumbler and tumbler support to insure proper balancing of basket.

8. Reassemble components onto dryer by reversing steps 3 through 6.
9. Check basket vertical/lateral alignment and adjust as found necessary.
10. Replace back guard .
11. Reestablish power to dryer.

H. Bearings (Refer to illustrations for section "F" pulleys)

To Replace Rear Tumbler (Basket) Support Pillow Block Bearing

1. Discontinue power to dryer.
2. Remove back guard.
3. Remove basket pulley (20").
4. Loosen lateral adjustment jam nuts and bolts. (Refer to illustration in section G.) ("Basket Alignment")
5. Loosen set screws (2) from rear pillow block bearing collar.
6. Remove the rear bearing bolts, securing bearing to bearing mount. Remove bearing.
7. Replace by reversing steps 3 through 6.
8. Adjust both lateral and vertical basket alignment.
9. Replace back guard.

10. Reestablish power to dryer.

To Replace Front Basket Support Pillow Block Bearing

1. Discontinue power to dryer.
2. Remove back guard.
3. Follow steps 3 through 6 from "Replacement of Rear Basket Support Pillow Block Bearing."
4. Remove the two (2) bolts holding the front basket support pillow block bearing to the dryer.
5. Loosen bearing collar set screws (2) and as the end of the basket shaft is lifted up slightly, slide the bearing off the shaft.
6. Prop a block of wood between the basket shaft and the bearing mount to keep the basket level and in place.
7. Replace by reversing steps 2 through 6.

NOTE: Before replacing back guard, check basket lateral/vertical adjustment, as well as, belt adjustment. Correct as found necessary.

8. Reestablish power to dryer.

To Replace Front Idler Shaft Pillow Block Bearing (bearing nearest the back of the dryer)

1. Discontinue power to dryer.
2. Remove V-belts from idler pulleys.
3. Remove bolts holding each idler pillow block bearing to mount.
4. Remove idler shaft (with both bearings and idler pulleys still attached) from dryer.
5. Remove end retaining ring and loosen the two (2) set screws in the ring collar.
6. Slide bearing off the shaft.
7. Replace bearing by reversing procedure.
8. Align idler pulley with basket pulley before tightening bolts.
9. Reestablish power to dryer.

To Replace Rear Idler Shaft Pillow Block Bearing

1. Follow steps 1 through 3 from "To Replace Front Idler Shaft Bearing."
2. Remove retaining rings on each side of forward idler shaft pillow block bearing.
3. Loosen the two (2) set screws on each bearing collar.
4. Slide both bearings off the shaft.
5. Replace by reversing procedure.
6. Reestablish power to dryer.

I. V-Belts (See Illustrations In Section F. "Pulleys")

V-belts should have proper tension. If too loose, they will slip; if too tight, excessive wear on the bearings will result. If the pulleys are not properly aligned, excessive belt wear will result. Proper belt tension will allow 1/2" displacement under normal thumb pressure at mid span of belt.

| NOTE: Belts must always be replaced in pairs (matched sets).

V-Belt Tension Adjustment (Basket to Idler)

1. Discontinue power to dryer.
2. Back off jam nuts on idler adjustment belts.
3. Tighten belts by turning both bolts evenly clockwise. (turn counterclockwise to loosen belts).
4. Check vertical plane of idler pulley for parallel alignment with basket pulley.
5. If realignment is required, loosen basket pulley and bushing, and move basket pulley to proper position.
6. Retighten jam nuts.
7. Reestablish power to dryer.

V-Belt Tension Adjustment (Motor to Idler)

1. Discontinue power to dryer.
2. Loosen the nuts on the four (4) studs holding the drive motor mount to the back of the dryer.
3. Loosen the jam nuts on the adjustment screw out the top of the motor mount.

4. Turn the adjustment screw to lower the motor mount (to tighten the belts) or raise the motor mount (to loosen the belts).
5. Check the vertical plane of the motor pulley and idler pulley for parallel alignment.
6. If realignment is required, loosen motor pulley and bushing and move motor pulley to proper position.
7. Retighten motor mount bolts and jam nuts.
8. Reestablish power to dryer.

To Replace V-Belts

1. Loosen tension on V-belts so that they can easily be rolled off pulleys.
2. Replace V-belts.
3. Retighten V-belts and adjust tension and alignment per previous instructions.

NOTE: Always replace V-belts in pairs.

J. Motors

To Replace Drive Motor

1. Discontinue power to dryer.
2. Remove drive belt.
3. Disconnect wiring harness from motor.
4. Remove bolts holding motor to mount and replace with new motor. Do not tighten bolts.
5. Remove pulley from old motor and install on new motor.
6. Align motor pulley with idler pulley and align motor shaft with idler shaft and tighten bolts.
7. Replace belts and adjust belt tension.
8. Retighten bolts.
9. Reestablish power to dryer.

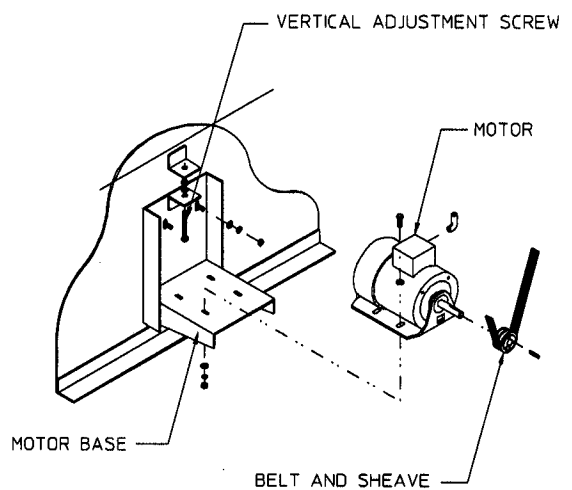

MAN/020

To Replace Impellor Motor

1. Discontinue power to dryer.
2. Disconnect motor harness from motor.
3. Remove nuts and washers holding the motor mount to the rear of the dryer and pull motor mount away.
4. Remove the two (2) left-hand jam nuts on the motor shaft retaining the impellor. Work the impellor free from the motor shaft by means of a wheel puller to prevent damage to the motor shaft.
5. Remove the bolts holding the motor to the motor mount and replace it with the new motor.
6. Align motor with impellor face in plane with the motor mount at no less than 3/16" clearance.
7. Reinstall the motor mount and reconnect the motor harness.
8. Reestablish power to dryer.

K. Impellor

To replace impellor, follow steps 1 through 4 of "To Replace Impellor Motor."

L. Lint Drawer Assembly

To Replace Lint Screen

1. Pull out lint drawer.
2. Remove lint screen from lint drawer.
3. Drop new lint screen in place.
4. Slide lint drawer back into dryer.

To Replace Lint Drawer Switch

1. Disconnect power to dryer.
2. Remove lint drawer and lint door.
3. Disconnect both 4-pin connectors at the rear of the lint switch cover.

4. Remove the four (4) screws holding the lint switch cover on.
5. Remove lint switch cover and disconnect the four (4) terminals of the switch.
6. Remove switch by pressing tabs together and push switch out.
7. Install new switch by reversing procedure.

SECTION VI

Troubleshooting

The information provided will help isolate the most probable components(s) associated with the difficulty described. The experienced technician realizes, however, that a loose connection or broken or shorted wire may be at fault where electrical components are concerned — not necessary the suspect component itself.

ELECTRICAL PARTS SHOULD ALWAYS BE CHECKED FOR FAILURE BEFORE BEING RETURNED TO THE FACTORY.

The information provided should not be misconstrued as a device for use by an untrained person in making repairs. Only properly licensed technicians should service the equipment.

Observe all safety precautions displayed on the equipment or specified in this manual while making repairs.

Refer to section "Electrical Troubleshooting" for a detailed troubleshooting procedure for electrical components.

1. No Display on computer.

- A. Open circuit breaker switch or blown fuse
- B. Bad wiring connection
- C. Faulty Computer controller

2. Computer will not except keypad entries

- A. Keypad ribbon connector is not plugged into computer securely
- B. Keypad is defective
- C. Faulty microprocessor (computer) controller.

3. Dryer will not start, but computer display indicators are on.

- A. Loose connection on yellow A/C door switch wires.
- B. Faulty door switch.
- C. Faulty Contactor.
- D. Defective MP.
- E. Defective Motor.

4. Drive motor runs, burner is on, but basket will not turn.

- A. Broken, damaged or loose V-belt
- B. Belts are contaminated (oil, grease, etc.)
- C. Loose or broken pulley

5. Drive motor and blower motor start, computer display heat indicator is on, but there is no heat.

- A. Lint coop automatic safety thermostat (225 degree) is defective
- B. Sail switch is out of adjustment, defective, or sail switch damper is not closing due to back pressure created by a restriction in the exhaust system
- C. Defective burner hi-limit (330 degrees) safety thermostat
- D. Defective ignitor/flame-probe assembly or probe is maladjusted
- E. Defective ignition DSI module
- F. Faulty gas valve
- G. Faulty microprocessor (computer) controller

6. Dryer operates, probe sparks, but gas does not flow.

- A. Dryer gas shut-off valve is closed
- B. Defective gas valve (open coil in valve)
- C. Bad wiring connection from DSI module to gas valve. (Check voltage at gas valve)
- D. Bad module

7. Dryer operates, probe sparks but there is no ignition even though gas is evident.

- A. Gas pressure is too low...Check manifold pressure and take necessary corrective action.
- B. Defective gas valve
- C. Ignitor probe is out of adjustment. (not within gas flow)
- D. Lint buildup in burner tubes

8. Dryer operates but is taking too long to dry.

- A. An inadequate exhaust duct work system
- B. Restriction in exhaust system
- C. Insufficient make-up air
- D. Poor housekeeping . . . dirty or clogged lint screen
- E. Washing machine extractors are not performing proper
- F. An exceptionally cold/humid or low barometric pressure atmosphere
- G. The supply gas may have a low heating value. Check with local gas supplier
- H. Faulty temperature sensor. (Temperature calibration is incorrect)
- I. Faulty microprocessor (computer) controller.

9. Thermal overload for drive motor is tripping.

- A. Either an exceptionally low or high voltage supply
- B. Motor bearing failure
- C. Bearing failure in drive system
- D. Motor vents are blocked with lint
- E. Defective motor
- F. Insufficient make-up air

10. Thermal overload for impellor (fan) motor is tripping.

- A. Either an exceptionally low or high voltage supply
- B. Motor bearing failure
- C. Motor vents are blocked with lint
- D. Defective Motor
- E. Out of balance impellor (fan)
- F. Insufficient make-up air

11. Dryer is cycling on burner hi-limit safety thermostat.

- A. Insufficient exhaust duct work...Size or restriction in exhaust system
- B. Insufficient make-up air
- C. Lint screen needs cleaning
- D. Damaged impellor (fan)
- E. Faulty microprocessor (computer) controller

12. Display reads "dSFL." Dryer Sensor Circuit Failure.

- A. Check 1/8" amp fuse on computer (if equipped with one)
- B. Faulty microprocessor temperature sensor probe
- C. Open circuit in either one of two (2) wires leading from the sensor probe to the computer
 - 1) Connection at sensor bracket assembly connector
 - 2) Connection at computer harness connector
- D. Faulty microprocessor (computer) controller

13. Dryer does not start. Display reads "door."

- A. Main door is open.
- B. Lint drawer is open.
- C. Open circuit in the wires (D.C. portion, the two gray wires) leading from the door switch to the computer.
- D. Open circuit in the wires (D.C. portion, the two gray wires) leading from the lint drawer switch to the computer

14. There is excessive vibration coming from the basket.

- A. Basket is out of adjustment

SECTION VII

Troubleshooting (Electrical)

1. No Display Condition

- A. Check main fuses or circuit breaker.
- B. Check fuse 1 or fuse 2 and if either are blown, replace.
- C. Across terminal block nos. 6 and 8 you should be getting your 208v or 240v.

If no voltage is present at 6 and 8, double check steps a and b and also check wires and terminations at these points.

- D. Take voltage reading across the microprocessor 15 pin connector nos. 5 and 7. To do this you must take off the strain relief of the connector (one Phillips screw) and and you will see the numbers 1 through 15 on the connector where the wires are going into the connector.

If there is voltage replace the computer.

If there is no voltage there is a bad wire(s) or termination(s) between terminal block nos. 8 and 6 and microprocessor 15 pin connector nos. 5 and 7.

*In this next section all voltage checks must be done in the operating mode with the appropriate microprocessor dot on!!!

*Certain models have fuses on the outputs of the computer (forward, blower, and reverse) be sure to check all fuses before continuing this section.

*In this next section when checking for voltage you are looking for 25AC volts unless otherwise specified.

2. Drive motor reverses but does not go forward, blower motor runs.

- A. If computer dot (first dot on the left) does not come on replace the computer.
- B. Check for voltage across the coil of the forward contactor located in the rear panel box. The contactor according to your diagram is marked CR3.

The coil markings are A1 and A2.

If voltage is present replaces coil or contactor.

If no voltage check for voltage across arc suppressor board BS1 terminals.

If voltage is present, there is bad wire(s) or termination(s) between BS1 and contactor coil (CR3).

- C. If there is no voltage between the two BS1 terminals, check for voltage across the two AS1 terminals of the arc suppressor board.

If there is voltage across the two AS1 terminals and no voltage across the two BS1 terminals, replace the arc suppressor board.

If there is no voltage across the two AS1 terminals on the arc suppressor board, the problem is a bad wire(s) or termination(s) between the AS1 board and the 15 pin computer connector, or faulty computer.

3. Drive motor works in forward mode but does not reverse, blower motor runs.

- A. If computer dot (second one from left) does not come on, check program to see if set for reverse.

- B. If set for reverse replace computer.

- C. Check for voltage across the coil of the reversing contactor located in the rear panel box. The contactor according to your diagram is CR2, also the markings on the coil is A1 and A2.

If there is voltage replace the coil or the complete contactor.

If there is no voltage, check for voltage across the two BS2 terminals on the arc suppressor board.

If there is voltage across the two BS2 terminals and no voltage across the coil of the reversing contactor (A1 and A2). The problem is bad wire(s) or termination(s) between BS2 and the contactor coil.

- D. If there is no voltage between the two BS2 terminals on the arc suppressor board, check for voltage across the two AS2 terminals on the board.

If there is voltage across the two AS2 terminals and no voltage across the two BS2 terminals, replace the arc suppressor board.

If there is no voltage across the two AS2 terminals, the problem is bad wire(s) or termination(s) between the arc suppressor board and the computer 15 pin connector, or a faulty computer.

4. Blower motor does not operate, drive motor runs.

- A. Check for voltage across terminals A1 and A2 of the impellor contactor. This is the single contactor in rear control box, not the double one.

If voltage is present check for voltage across the blower motor. If there is voltage at the blower motor replace the motor.

If there is no voltage at the blower motor, problem is bad wire(s) or termination(s) between the contactor and the motor.

- B. If there is no voltage present at A1 and A2 of the contactor, check for voltage across the two BS3 terminals of the arc suppressor board.

If there is voltage present at the two BS3 terminals, problem is bad wire(s) or termination(s) between the two BS3 terminals and the coil (A1 and A2) terminals.

If there is no voltage across the two BS3 terminals, check for voltage across the two AS3 terminals.

If there is voltage across the two AS3 terminals and there is no voltage between the two BS3 terminals, replace the arc suppressor board.

- C. If there is no voltage across the two AS3 terminals, problem is bad wire(s) or termination(s) between the two AS3 terminals and the computer board 15 pin connector no. 15 or faulty computer.

5. Both drive motor and blower motor not operating. (Display reading is normal. Indicator dots are on.)

- A. Check for voltage across terminal block nos. 5 and 2. If there is no voltage there replace the 24AC volt transformer.

- B. If there is voltage at these two points, check for voltage across terminal block nos. 7 and 2. If there is no voltage across those two points, problem is either or both the lint door and main door switches are defective, or bad wire(s) or termination(s) between these two switches and or to the terminal block nos. 5 and 7.

| NOTE: See section 8 for a more detailed explanation of both door switches.

If there is voltage across terminal block nos. 5 and 7, check for voltage across terminal nos. 2 and socket nos. 6 of the 15 pin microprocessor connector. (Remove strain relief by removing Phillips screw. You will see little numbers on the connector where the wires are going into it).

If there is voltage across terminal block nos. 2 and 6 of the 15 pin microprocessor connector, check for voltage across AS1, AS2, and AS3 of the arc suppressor board in the rear control panel.

If you don't see voltage across any two of those three test points, problem is bad wire(s) or termination(s) between the arc suppressor board and the 15 pin microprocessor connector or a faulty computer.

If you do see voltage across any two of these three points, check for voltage right across the board to the corresponding "B" side.

If there is no voltage on the "B" side of the arc suppressor board and there is voltage on the "A" side, problem is faulty arc suppressor board.

- C. If there is voltage at any two of the three test points on the "B" side of the arc suppressor board, check for voltage across the coils (marked on the contactor A1 and A2) of the reversing and impeller contactor.

| NOTE: Only two of these coils will be energized at one time.

If there is voltage across any two of these three coils, problem is either the coil or the motor. The way to determine if the problem is the motor is to take a voltage reading across the L1, L2, and L3 leads of the motor. If there is voltage at the motor then it is a faulty motor.

If there is no voltage across any two of these three coils, problem is bad wire(s) or termination between arc suppressor board and the coil(s).

6. "No heat" drive and blower motor runs, display reads normal (gas models).

- A. Check for voltage across terminal block nos. 3 and 2.

If no voltage, problem is faulty 225 degree thermostat located underneath the basket on the temperature sensor bracket, or bad wire(s) or termination(s) from that thermostat to the terminal block.

If there is voltage across terminal block 3 and 2, check for voltage across terminal block no. 2 and the "HI" terminal on the computer.

If there is no voltage, problem is bad wire(s) or termination(s) between the "HI" terminal on the computer and the terminal block no. 3.

If there is voltage across terminal block no. 2 and the "HI" terminal on the computer, leave the meter lead on the terminal block no. 2 and move the other lead over to the "HO" terminal on the computer.

- B. If there is no voltage across these two points, problem is faulty computer.

If there is voltage across the "HO" terminal on the computer and the terminal block no. 2, check for voltage across the "TH" terminal and the "GND" terminal on the D.S.I. module.

If there is no voltage at those two points, problem is bad sail switch or hi-limit switch or any of their wires or terminations between the "TH" on the D.S.I. module and the computer "HO" terminal.

If there is voltage, problem is faulty D.S.I. module.

| NOTE: For more information on troubleshooting the D.S.I. system, see the D.S.I. supplement.
P/N: 450119

7. "No heat" drive and blower motor runs, display reads normal (steam).

A. Check for voltage across terminal block nos. 3 and 2.

If there is no voltage, problem is faulty thermostat located underneath the basket on the temperature sensor bracket, or bad wire(s) or termination(s) between the thermostat and the terminal strip.

If there is voltage across terminal block 3 and 2, check for voltage across terminal block no. 2 and the "HI" terminal of the computer.

If there is no voltage, problem is bad wire(s) or termination(s) between the "HI" terminal on the computer and the terminal block no. 3.

If there is voltage across terminal block no. 2 and the "HI" terminal on the computer, leave the meter lead on terminal block no. 2 and move the other lead to the "HO" terminal on the computer.

B. If there is no voltage at those two points ("HO" and terminal block no. 2), problem is faulty computer.

If there is voltage across the "HO" terminal and terminal block no. 2, check for voltage across the two black wires of the steam damper solenoid.

If there is voltage across those two black wires and the damper is not opening, problem is faulty steam damper solenoid.

If there is no voltage across those two black wires, problem is bad wire(s) or termination(s) between the "HO" terminal on the computer and the steam damper solenoid.

8. Both drive and blower motors run a few minutes then stop or motors don't start at all... display is normal and indicator dots are on.

A. Check for voltage across terminal block nos. 5 and 2. If there is no voltage, problem is faulty 25VAC transformer.

| Note: Be sure to check the 3 amp very fast acting, fuse to see if it's open.

If there is voltage across terminal block nos. 5 and 2, check for voltage across both leads of the lint door switch. To accomplish this and also the following, clip one of the meter leads to the chassis ground, and probe with the other lead accordingly:

- 1) If there is no voltage across either two leads, problem is bad wire(s) or termination(s) from the terminal block no. 5 to the lint door switch.
- 2) If there is voltage only across one lead, then the lint door switch is faulty.
- 3) If there is voltage across both leads of the lint door switch, check for voltage across both leads of the door switch.

- 4) If there is no voltage across either two leads of the door switch, problem is bad wire(s) or termination(s) of the lint door switch to the door switch.
- 5) If there is voltage across only one lead, then the door switch is faulty.
- 6) If there is voltage across both leads of the door switch, check for voltage across terminal block nos. 7 and 2.
- 7) If there is no voltage across 7 and 2, problem is bad wire(s) or termination(s) from terminal block no. 7 and the door switch.
- 8) If there is voltage across terminal block 7 and 2, leave one meter lead on terminal block no. 2 and with the other lead check for voltage on pin 6 of the microprocessor 15 pin connector. To accomplish this you must take off the strain relief (one Phillips screw) and where the wires are going into the connector, there are numbers on the connector.
- 9) If there is voltage across terminal block no. 7 and microprocessor pin no. 6, problem is faulty computer.
- 10) If there is no voltage across terminal block no. 7 and microprocessor pin no. 6, problem is bad wire(s) or termination(s) between terminal block no. 7 and microprocessor pin no. 6.

9. Dryer will be running fine, both motors and heat working, then just stops. Microprocessor display reads time or percent of extraction and all indicators dots are off.(If a keyboard entry is made, display reads "door").

- A. Unplug the two gray wire inline connectors up in the computer box area. These have seen through plastic coating on the spade terminals. Across the two gray wires going into the computer should read 5 DC volts.

If there is no voltage across those two gray wires that are going into the microprocessor connector (5 DC volts), problem is bad wire(s) or termination(s) from the plastic inline connectors to the microprocessor 15 pin connector or faulty computer.

If there is the 5 DC volts at those two gray wires, check for continuity across the other set of gray wires going down to the lint and main door switches.

| NOTE: Make sure both the lint and main doors are closed and making contact on their switches.

- B. If there is continuity across those two gray wires going down to the lint and main door switches, problem is either both or one of the plastic inline connectors. There is a bad connection when they are met together with the spade terminals or essentially not pushed in enough.

If there is no continuity across those two gray wires going down to the lint and main door

switches, you must take continuity readings across the lint door and main door switches. This must be done at the gray wire terminals of the switches. If there is no continuity at the switch, then that switch is faulty. If both switches check out ok then the problem is a break in the wiring or bad connection or termination on these wires that go to the switches and than up to the computer box area.

10. Microprocessor reads "DSFL."

NOTE: Before continuing with this section check the .125MA fuse on the computer board (if applicable).

- A. Replace the temperature sensor underneath the basket on a bracket, (the bullet shaped device).
- B. If it still reads "DSFL," unplug the 4 pin connector from the temperature sensor bracket. Also unplug the microprocessor 15 pin connector from the computer board. Remove the strain relief from the 15 pin connector (one Phillip screw). Where the white/red striped wire is going into the connector, take a continuity reading across that wire and that same wire from the 4 pin connector that you unplugged earlier in this paragraph.

If there is no continuity, check for break in wire, a short to the ground, loose termination(s), or even replace the wire.

If there is continuity, do the same thing to the black wire right next to the white/red striped wire in the 15 pin connector.

If there is no continuity, check for break in wire, a short to the ground, loose termination(s), or even replace the wire.

If there is continuity, computer board is faulty.

SECTION VIII

Technical Information

The following section contains various technical information important to the service person in servicing and maintaining the dryer.

A. Motor plate (High and Low Voltage)

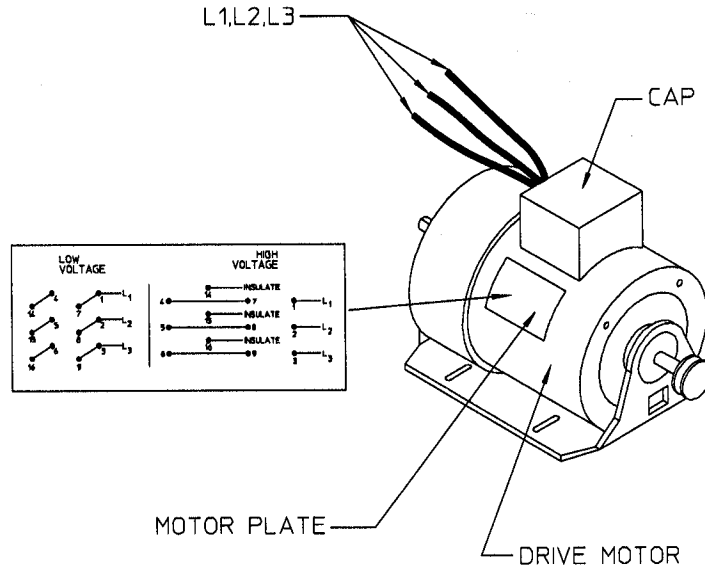

MAN0557

The motor plate is located on the side of the drive motor (see illustration) and contains a graphical representation of the motor wiring for both low voltage rating and high voltage rating.

Removing the cap reveals the wiring to the motor. On each wire there is a number which corresponds to the numbers on the motor plate. Depending on whether the dryer is operating on low voltage or high voltage, the wiring should match the motor plate as follows:

The dots and lines represent connections (see illustration). For example:

On Low Voltage - Wire #14 is connected to wire #4.

- Wire #1 is connected to wire #7. Which are both connected to L1.

On High Voltage - Wire #14 is insulated or capped.

- Wire #4 is connected to wire #7.

- Wire #1 is connected to L1.

B. Data Label

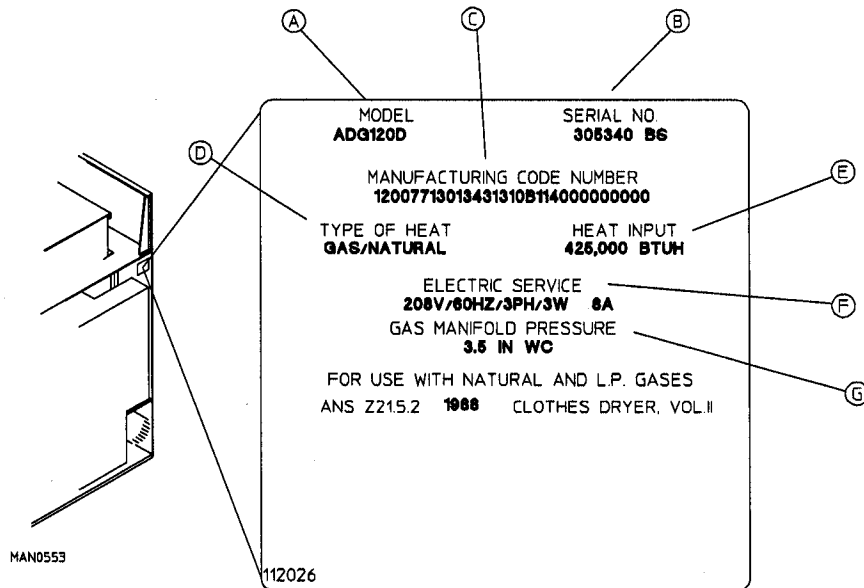

Contacting American Dryer Corporation (ADC)

When contacting ADC, certain information is required to insure proper service/parts information. This information is on the data label located on the top right corner of the dryer viewed from the rear (see illustration). When contacting ADC, please have the model number and serial number handy.

Information on the Data Label

- a. Model number - the model number is an ADC number which describes the size of the dryer and the type of heat (gas or steam).
- b. Serial number - the serial number allows ADC to gather information on your particular dryer.
- c. Manufacturing code number - the manufacturing code number is a number issued by ADC which describes all possible options on your particular model.
- d. Type of heat - Describes the type of heat: gas (natural or L.P.) or steam.
- e. Heat input - (for gas dryers) describes the heat input in British Thermal Units.
- f. Electric service - describes the electric service for your particular model.
- g. Gas manifold pressure - describes the manifold pressure as taken at the gas valve. (see "Using a Manometer")

C. Using a Manometer

HOW TO USE A MANOMETER

1. With dryer in nonoperating mode, remove plug on the gas valve pressure tap.
2. Attach plastic tubing to pressure tap. (Fitting is supplied with manometer. See illustration.)
3. Attach manometer to dryer using magnet.

NOTE: Place manometer in a position so that readings can be taken at eye level.

4. Fill manometer as shown in illustration to the zero level.
5. Start dryer. With burner on, take a reading.
 - a. Read water level at the inner tube. Readings should be taken at eye level.
 - b. Correct readings should be:

Natural Gas: 3.5 to 4.0 Inches W.C.

L.P. Gas: 10.5 to 11 Inches W.C.
6. If water column pressure is incorrect, refer to "To Adjust Gas Pressure" on page 19.
7. Reverse procedure for removing manometer.

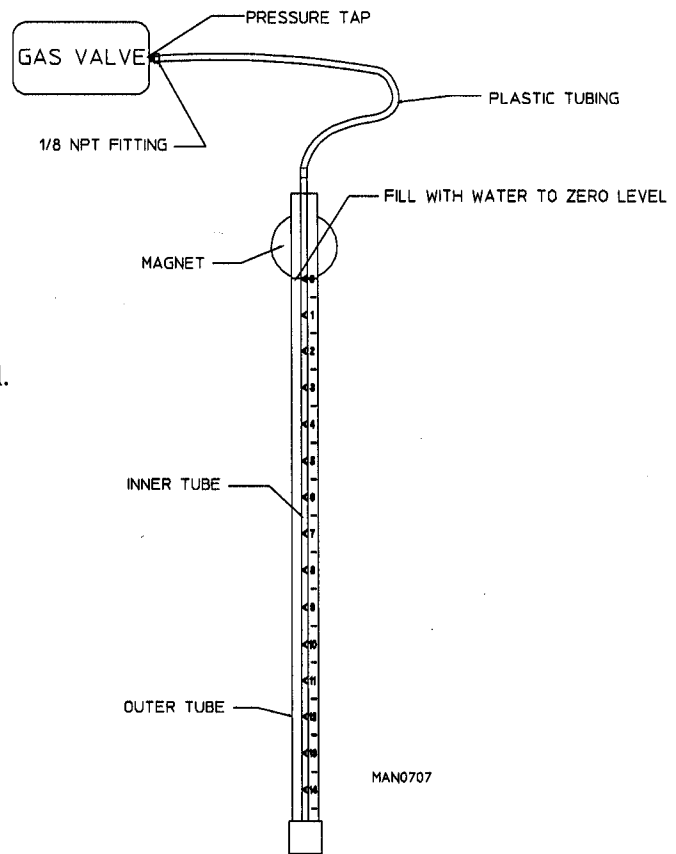

D. L.E.D. Display/Codes

The L.E.D. display informs user of cycle status and program verification and displays important diagnostic and fault codes.

1. Display Operating Status

- a. Cycle in Progress - While the dryer is operating, the display will read which cycle is in progress. For example, in the drying cycle (mode), the display will read "dr," and in the cool down cycle (mode), the display will read "CL."
- b. Cycle Status - While a cycle is in progress, the display will show the progress of the cycle (load) that is being processed.
 - 1) Automatic Drying Cycle - The cycle status portion of the display will show the percentage of extraction.
 - 2) Timed (Manual) Drying Cycle - The cycle status portion of the display will show the drying or cool down time and will count downward until the programmed time has expired.
- c. Alternate Display Programs - Programming allows for the display to read just the basket temperature or flash back and forth from cycle in progress or tumble - temperature while the dryer cycle is in progress. Unless otherwise specified at the time of ordering the dryer, the microprocessor controller is programmed not to flash and to read cycle in progress.
- d. Indicator Dots - Located at the top of the display is a series of dots which indicate the various microprocessor controller output functions while a cycle is in progress.

Illus. No. 3 - ON INDICATOR - This indicator dot is on whenever a cycle is in progress. In addition, when the anti-wrinkle program is active, this indicator dot will be on whenever the microprocessor controller is in the guard on time program.

Illus. No. 4 - HEAT INDICATOR - This indicator dot is on whenever the microprocessor controller is calling for the heating unit to be active (on).

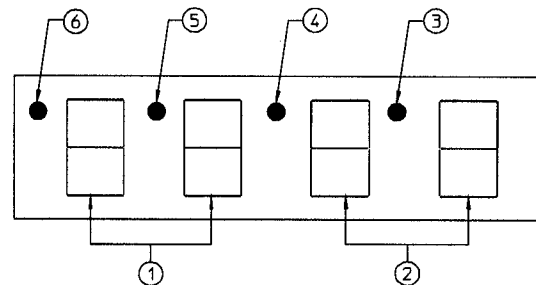

1. CYCLE IN PROGRESS
 - a. dr -- DRYING CYCLE
 - b. CL -- COOL DOWN CYCLE
2. CYCLE STATUS
 - a. AUTOMATIC MODE DISPLAYS % OF EXTRACTION
 - b. MANUAL MODE DISPLAYS DRYING TIME OR COOL DOWN TIME
3. ON INDICATOR, DRYER IS IN OPERATING MODE
4. HEAT ON INDICATOR
5. BASKET IN REVERSE MODE (C.W.) INDICATOR
6. BASKET IN FORWARD MODE (F.W.) INDICATOR

MAN0554

Illus. No. 5 - REVERSE INDICATOR - This indicator is functional for models with the reversing action option only. This indicator will be on when the basket is in the reverse (counterclockwise) direction.

Illus. No. 6 - FORWARD INDICATOR - This indicator dot is functional only for models with the reversing action option only. This indicator will be on when the basket is in the forward (clockwise) direction. In addition, when the anti-wrinkle program is active, this indicator dot will be on whenever the microprocessor controller is in the guard on time program.

Codes

A	Slope Program Factor
AUtO	Automatic Mode
ArEv	Always Reverse
b	Heat Loss (offset) Factor
bUZ	Buzzer (tone)
bUZ—tinE	Buz Time
CEL	Degree in Celsius
CL	Cool Down Cycle in Progress
COOL-tinE	Cool Down Time
COOL-tEnP	Cool Down Temperature
CY A	Preprogrammed Cycle A
CY b	" " b
CY C	" " C
CY d	" " d
CY E	" " E
CY F	" " F
CYCL—tinE	Cycle Display Time
d	Dryness Level (percentage of extraction)

donE	Drying or Cooling Cycles Complete or Dryer is in Anti-Wrinkle Program
door	Door Circuit is Open or Fault in DC door switch circuit.
dr	Drying Cycle in Progress
drY—LEvL	Dryness Level (percentage of extraction)
drY-tEnP	Drying Temperature
dSFL	Dryer Sensor Circuit Failure
F	Fabric (temperature)
FAr	Degree in Fahrenheit
FILL	No Cycle in Progress
FLS	Flash Display Active
GdLY	Anti-Wrinkle Delay Time
G on—tinE	Anti-Wrinkle On Time
Grd	Anti-Wrinkle Program Active
LC	Load Cool Down Time
Ld	Load Drying Time
MAnU	Manual Mode
MGrd	Maximum Guard Time
nbUZ	No Buzzer (tone)
nFLS	No Flash Display
nGrd	Anti-Wrinkle Program is Not Active
nrEv	No Reverse
ProG	Program Mode

rEv	Reverse
Sr	Select Reverse
SrEv	Select Reverse
tEnP	Temperature (see Fault Codes)
tEnP—ti	Temperature Display Time
tinE	Time

Fault Codes

1. door - Keyboard entry was made while main door was open
or
Fault in D.C. door switch circuit.
2. dSFL - Fault in microprocessor temperature sensor circuit.
3. tEnP - Heat default condition. To cancel "tEnP" default code, press "Clear/Stop" key. If "tEnP" condition persists, there is a problem with the dryer heating unit or circuits to heating unit.

E. Computer Logic and Wiring Diagram

COMPUTER LOGIC AND WIRING DIAGRAM

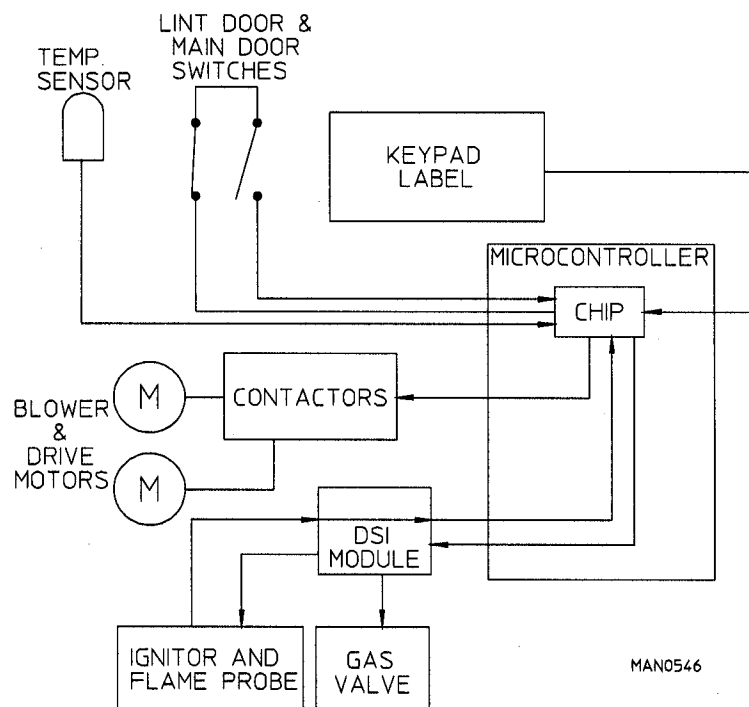

1. Operator enters desired selection(s).
2. Information entered is sent to the micro-controller via the keyboard.
3. The input information is sorted/processed and executed by the micro-computer chip.
4. The micro-computer output signal activates the contactors and DSI module which control machine functions.

NOTE: When contacting ADC with electrical questions, please have on hand the correct wiring diagram number for your particular machine. This number is located on the top right-hand corner of the diagram. It is a six (6) digit number followed by a letter to distinguish the revision dates. (see illustration)

The wiring diagrams used in Troubleshooting is specifically for dryers manufactured at the time of publishing. Your particular model may vary slightly depending on the date of manufacturing and options available. The correct wiring diagram and number is taped to the rear of the control door on each dryer.

F. AD-120 Tool List

Straight Head Screwdriver

Phillips Head Screwdriver

Sensor Pin and Socket Tool (P/N 122801)

Pliers

1/4" Nut Driver

3/8" Open End Wrench

5/8" Open End Wrench

5/8" Deep Socket Ratchet

3/8" Socket Wrench

1/2" Socket or Open End Wrench

1/4" Open End Wrench

5/16" Socket or Open End Wrench

1/2" Socket Wrench

7/16" Socket or Open End Wrench

5/16" Nut Driver

(2)12" Pipe Wrench

1/8" "T" Shaped or "L" Shaped Allen Wrench

3/16" "T" Shaped or "L" Shaped Allen Wrench

Wire Cutters

1/2" Allen Wrench

3/8" Allen Wrench

Channel Locks

Manometer (ADC part no. 122804)

MP Pin Extraction Tool (ADC part no. 122800)

ADC 450106 1 - 08/17/93-100 2 * 12/24/96-100

